

PulsaCoil BP SOL

Open vented hot water cylinder utilising off-peak electric and solar power

Design, Installation & Servicing Instructions



Models covered in this manual

- PulsaCoil PCBP 150 SOL
- PulsaCoil PCBP 180 SOL
- PulsaCoil PCBP 220 SOL

These instructions must be read in conjunction with the standard PulsaCoil BP design, installation and servicing instructions before installation

ISSUE 3: JANUARY 2014

Section	Page
DESIGN	
Introduction	3
Technical Data	4
SERVICING	
Short Parts List	7
Terms & Conditions	8
BENCHMARK	
Commissioning Checklist	10
Service Record	11



The Building Regulations (England & Wales) require that the installation of a heating appliance be notified to the relevant Local Authority Building Control Department. From 1st April 2005 this can be achieved via a Competent Person Self Certification Scheme as an option to notifying the Local Authority directly. Similar arrangements will follow for Scotland and will apply in Northern Ireland from 1st January 06.

Benchmark places responsibilities on both manufacturers and installers. The purpose is to ensure that customers are provided with the correct equipment for their needs, that it is installed, commissioned and serviced in accordance with the manufacturers instructions by competent persons and that it meets the requirements of the appropriate Building Regulations. The Benchmark Checklist can be used to demonstrate compliance with Building Regulations and should be provided to the customer for future reference.

Installers are required to carry out installation, commissioning and servicing work in accordance with the Benchmark Code of Practice which is available from the Heating and Hot Water Industry Council who manage and promote the Scheme. Visit www.centralheating.co.uk for more information.

For further information on the HWA Charter Membership, please refer to the HWA website hotwater.org.uk.

The Gledhill PulsaCoil range is a WBS listed product and complies with the HWA Specification for hot water only thermal storage products. The principle was developed in conjunction with British Gas. This product is manufactured under an ISO 9001:2008 Quality System audited by BSI.

Gledhill's first priority is to give a high quality service to our customers.

Quality is built into every Gledhill product and we hope you get satisfactory service from Gledhill.

If not please let us know.

DESIGN

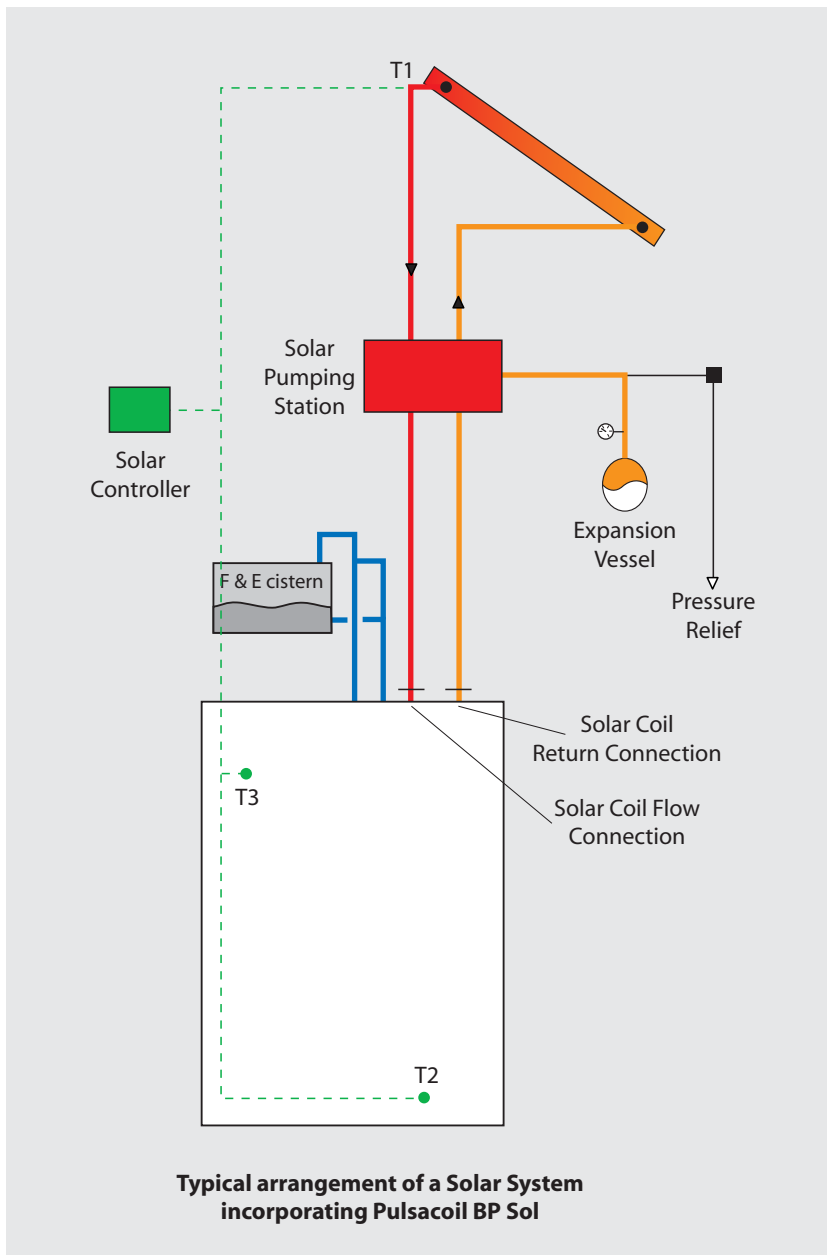

The arrangement and components of a Pulsacoil BP Sol appliance are shown schematically above and on page 4.

The current solar appliance is based on the standard Pulsacoil appliance and this addendum must be read in conjunction with the Design, Installation and Servicing Instructions provided for the standard appliance.

The basic difference between this and a standard Pulsacoil appliance is the addition of a solar coil at the bottom of the thermal store.

Because this product does not require a safety discharge from a temperature and pressure relief valve, any installations will be easy to incorporate into the building and will not suffer from the problems associated with using PVCu soil stacks to take the discharge from unvented cylinders.

All the equipment and controls for the solar system will need to be designed, supplied and installed by the Solar installer from the connections provided on top of the appliance.

However, a pair of sensor pockets T2 and T3 are provided on the Pulsacoil BP SOL. A 10mm dry pocket is provided at low level (T2) for the installation of a solar control sensor. Another 10mm dry pocket is provided at high level (T3) for the high limit thermostat (to be provided by the installer) to prevent the store temperature rising above 85°C. This is usually done by stopping the solar input to the Pulsacoil. A further control sensor will also need to be provided by the installer adjacent to the solar collector (T1). See diagram on page 5 for further details.

A safety device (pressure relief valve) to control the risk of over-pressure in system components should be fitted as shown on the Solar System diagram. A termination from a safety pressure device should minimise the risk of damage to persons or materials. Suitable locations are a high temperature receptacle, an internal gully or else issue externally at ground level. High level termination from walls or on roofs could cause injury to people or animals below if the valve were to release scalding water and steam.

The pipe leading to the safety device and the collector should be of rigid and non-deformable construction, without any possibility of restriction or disclosure by any other fitted component.

To obtain maximum benefit from this appliance it is recommended that it is used in conjunction with an Economy 7 off peak electrical tariff.

If the appliance is used with an on peak tariff it is recommended that a time clock is fitted on the electrical supply to the off peak (bottom) immersion heater. This should be set to charge the store overnight and allow the solar to replenish the store during the day.

The standard manual fill model is shown opposite but an automatic fill model with ball valve and overflow can be provided if ordered as an optional extra.

In order to meet the Building Regulations requirement to reduce the rate of accumulation of scale in hard water areas, it is important that the installer checks the hardness of the incoming water supply.

If this exceeds 200ppm (mg/l), we recommend that the factory fitted scale inhibitor is ordered as an optional extra.

If it exceeds 300ppm (mg/l), we recommend the use of a polyphosphate type of scale inhibitor. This can also be ordered as an optional extra but will need fitting on site by the installer.

DESIGN

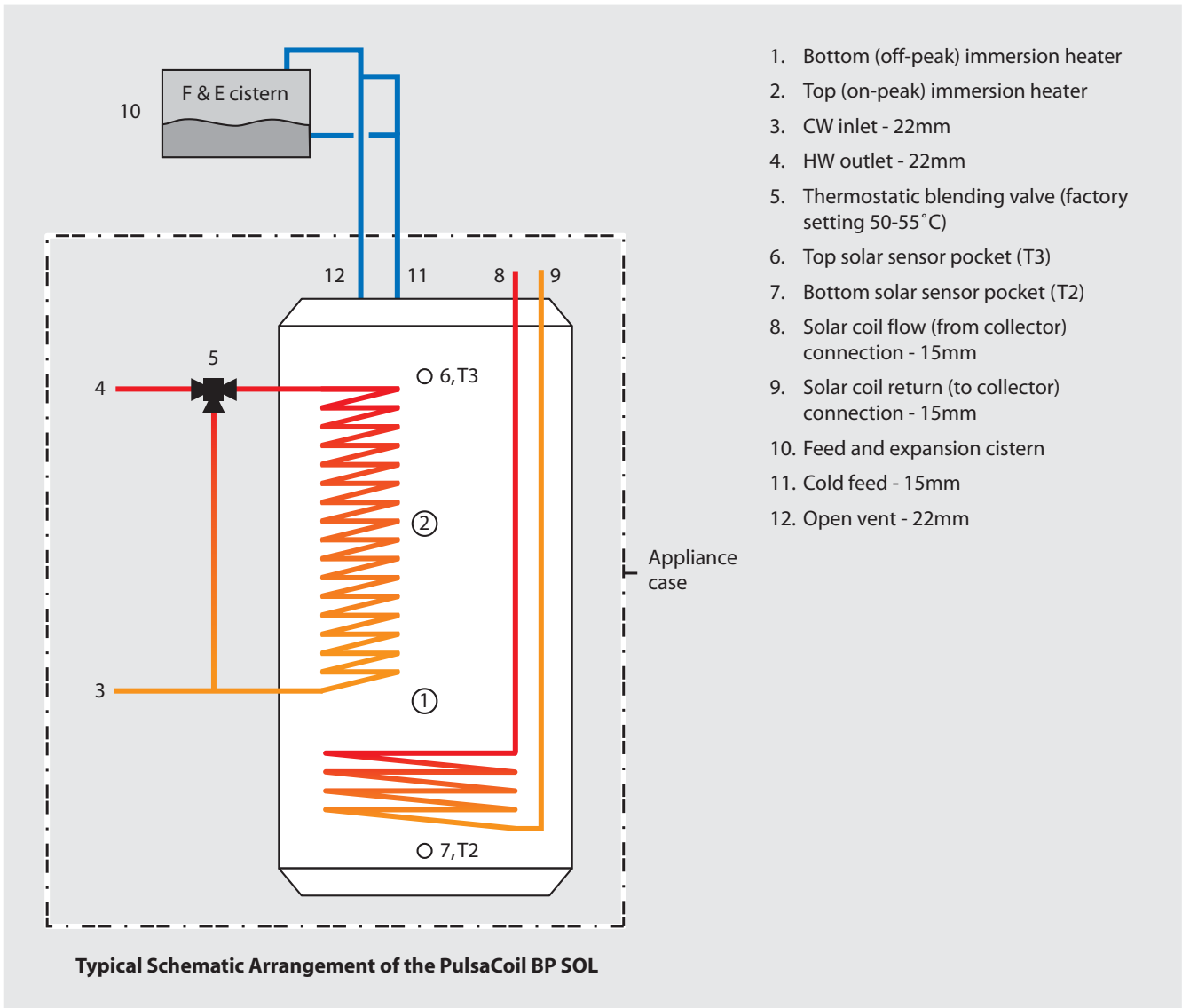

Schematic arrangement of extra wiring required for solar appliance (including high temperature interlock)

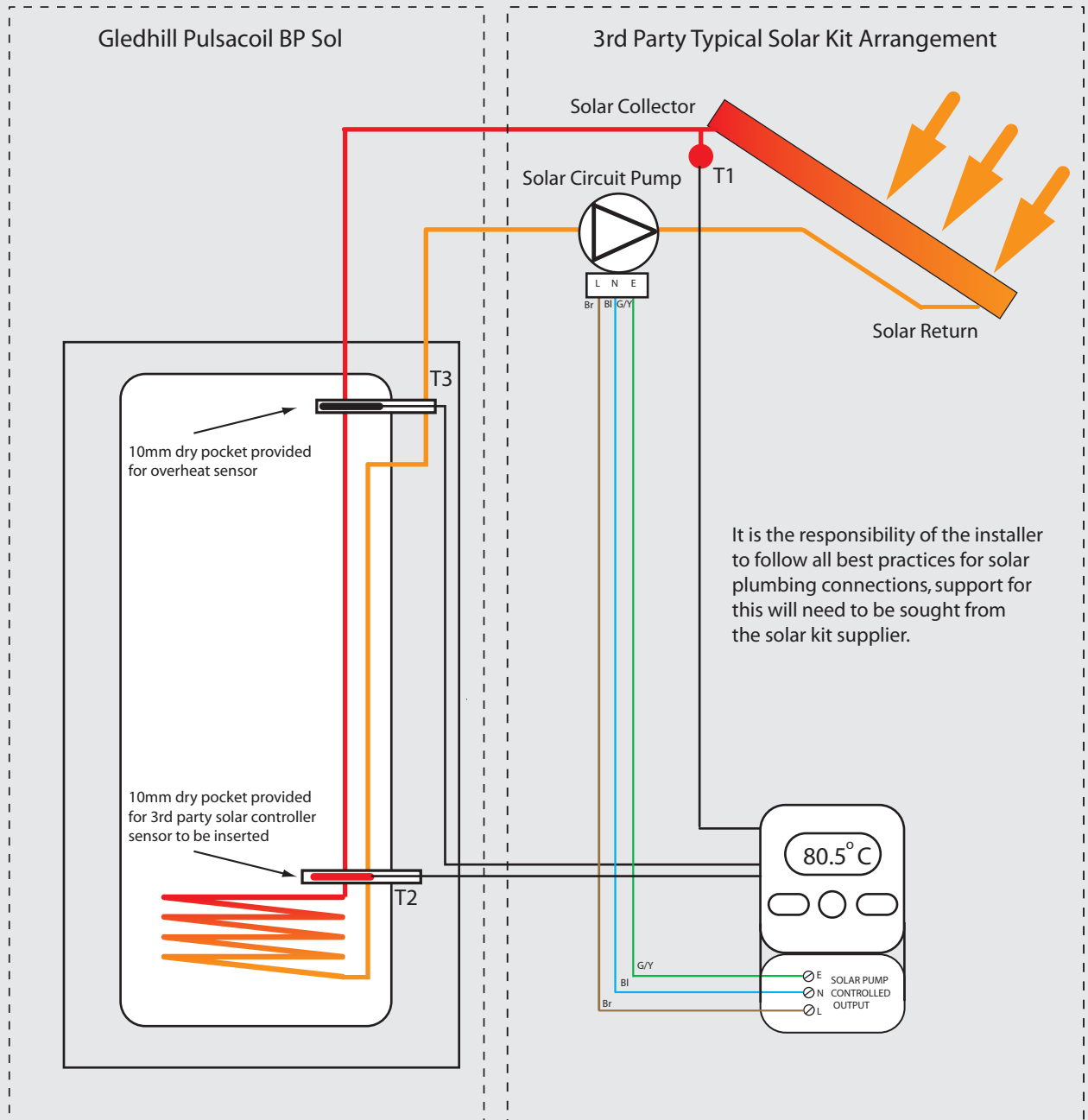

This diagram must be used in conjunction with the full Pulsacoil BP wiring diagram in the Design, Installation and Servicing Instruction Manual.

Complete Solar Kit supplied and fitted by Installer. The Pulsacoil BP Solar appliance is supplied with the following additional items:-

1. 15mm copper solar collector pipe connection
2. 15mm copper solar return pipe connection
3. 10mm diameter dry pocket for solar control sensor

DESIGN

Technical Specification of PulsaCoil BP SOL					
Models			PCBP150SOL	PCBP180SOL	PCBP220SOL
Overall dimensions	Height	(mm)	1332	1533	1734
	Width	(mm)	560	560	560
	Depth	(mm)	605	605	605
Minimum cupboard dimensions	Height	(mm)	2082 ⁽³⁾	2283 ⁽³⁾	2484 ⁽³⁾
	Width	(mm)	600	600	600
	Depth	(mm)	620	620	640
Hot and cold water		(mm)	22	22	22
Solar Pipe Connections	Collector	(mm)	15	15	15
	Return	(mm)	15	15	15
Maximum hot water flow rate ⁽¹⁾		(l/min)	18	22	22
Weight	Empty	(kg)	69	78	85
	Full	(kg)	219	258	295
Dwelling Type					
	Bedrooms		1	1-2	1-2
	Bathrooms		1 or	1 or	1
	En-suite		1	1	1
Maximum Floor Area ⁽⁴⁾		(m ²)	40	50	65
Maximum System Pressures					
	Thermal Store	Open Vented	6m	6m	6m
	Solar System	(bar)	6	6	6
	Mains pressure hot water	(bar)	5	5	5
SAP 2005 Data					
Storage Volumes	Total	(litres)	150	175	200
	Solar	(litres)	57	64	73
Heat loss declared ⁽²⁾		(kWh/24h)	1.31	1.5	1.6
Temperature factor		-	0.721	0.721	0.721
Area of solar heat exchanger		(m ²)	1.31	1.31	1.31

1. This flow rate is based on a 35°C temperature rise and assumes that the recommended pressures and adequate flow are available at the appliance.
2. The heat losses from thermal stores should not be directly compared with heat losses from unvented or vented cylinders because they are treated differently in SAP. The SAP calculator takes account of the type of store and various correction factors are included to reflect the different ways that the hot water and heating operates.
3. This height allows for the installation of the single F&E cistern in the same cupboard as the Pulsacoil BP appliance (complete with ballvalve - if specified).
4. For compliance with Building Regulations Part L1.

For any further technical information/assistance regarding this product please ring the Gledhill Technical Help line on 01253 474584.

SERVICING

	Description	Stock Code
1	Top immersion heater - Incalloy 825 immersion heater - with dual (control & safety) thermostat.	XB483
2	Bottom immersion heater - Incalloy 825 immersion heater - with dual (control & safety) thermostat.	XB483
3	Brawa mix thermostatic hot water blending valve	XC007
4	Scale inhibitor PCB	XB142



Gledhill (Building Products) Ltd

AMD.DECEMBER 2013

CONDITIONS OF SALE & GUARANTEE TERMS

1. Gledhill (Building Products) Ltd ("We" or "Gledhills") only do business upon the Conditions which appear below and no other. Unless we so agree in writing these Conditions shall apply in full to any supply of goods by us to the exclusion of any Conditions or terms sought to be imposed by any purchaser. These Conditions of Sale and Warranty Terms override those which are contained on the Invoice Forms and all Sales are now subject to these Conditions of Sale and Warranty terms only.

2. PRICE

Once an order or call off has been accepted the price will be held for three months **but if delivery is extended beyond that period at the customer's request, then we reserve the right to amend the price when necessary.** The company reviews its pricing annually to adjust for changes in our cost base. We reserve the right to alter prices at any time for severe movements in raw materials (mainly copper and steel). If there is to be a change we will give customers at least four weeks notice but anything delivered after that date will be at the revised price. An order may not be cancelled or varied after acceptance without the written consent of the company. Such cancellation or variation shall be subject to such reasonable charges as may be appropriate.

3. SPECIFICATION

The goods are supplied in accordance with the Specifications (if any) submitted to the Purchaser and any additions and alterations shall be the subject of an extra charge. Any goods not so specified shall be in accordance with our printed literature or the literature of any of our component suppliers (subject to any modifications made since publication). If we adopt any changes in construction or design of the goods, or in the specification printed in our literature, the Purchaser shall accept the goods so changed in fulfilment of the order.

4. PAYMENT

The buyer shall make payment in full within thirty days from the end of the month in which the invoice is dated. If we receive payment in full on or before the due date we will allow an appropriate settlement discount except where we have quoted a special net price. If payment is not received in full on or before the due date we shall be entitled in addition to the invoice price to:

- (i) payment of a sum equal to any increase in the copper price supplement applicable to the particular goods sold between the date of receipt of order and the date of receipt of payment in full; and
- (ii) interest on any part of the invoice price unpaid after the due date at the rate of 3% per annum over the base rate for the time being of HSBC Bank plc.

5. TIME

We give estimates of delivery dates in good faith and time of delivery is not nor shall be made of the essence of any contract nor shall we be liable for any loss or damage occasioned by delay in delivery.

6. DELIVERY

We deliver free normally by our own vehicles within 25 miles of any of our manufacturing depots. Delivery to any place more than 25 miles from one of our manufacturing depots may be subject to our quoted delivery charges. We reserve the right to make delivery of goods contained in one order by more than one consignment and at different times. Where a period is agreed for delivery and such period is not extended by our Agreement, the Purchaser shall take delivery within that period. If the Purchaser fails to take delivery, we shall be entitled at the Purchaser's risk and expense to store the goods at the Purchaser's premises or elsewhere and to demand payment as if they had been despatched. Off loading at point of delivery shall be the responsibility of and be undertaken by the Purchaser.

7. SHORTAGES OR DAMAGE

Goods must be inspected before signature of delivery note and any damage, shortage or discrepancy noted on the delivery note and the goods returned on the same vehicle. The buyer must also give us immediate written notice of the damage, shortage or discrepancy so that we may prompt investigation.

8. RETURN OF GOODS

Goods may not be returned to the Company except by prior written permission of an authorised officer of the Company and such return shall be subject to payment by the Purchaser of handling and re-stocking charges, transport and all other costs incurred by the Company.

9. COMPANY LIABILITY AND GUARANTEE

9.1. Subject to the terms of these Conditions of Sale and Guarantee Terms Gledhills provide Guarantees in respect of specific products as set out in this clause.

9.2. Each Guarantee is strictly conditional upon the following:-

9.2.1. Complaints must be given to us immediately, before any action is taken, as responsibility cannot be accepted if repairs or renewals are attempted on site without our written approval.

9.2.2. The unit has been installed in accordance with our installation and service instructions and all relevant codes of practice and regulations in force at the time of installation.

9.2.3. All necessary inlet controls and safety valves have been fitted correctly.

9.2.4. The unit has only been used for the storage of potable water supplied from the public mains. The water quality shall be in accordance with European Council Directive 98/83 EC, or revised version at the date of installation, and is not fed with water from a private supply. Particular:

Chloride content:	Max. 200 mg/l
Sulphate content:	Max. 200 mg/l
Combination chloride/sulphate:	Max. 300 mg/l (in total)

9.2.5. Where appropriate the unit has been regularly maintained as detailed in the installation and service instructions

9.2.6. Defects caused by corrosion or scale deposits are not covered by any Guarantee.

9.2.7. Where we agree to rectify any defect we reserve the right to undertake the work on our own premises.

9.2.8. We will not accept any labour charges associated with replacing the unit or parts for any of the following products listed.

9.2.9. If the newly fitted water heater is not in regular use then it must be flushed through with fresh water for at least 15 minutes. Open at least one hot water tap once per week, during a period of at least 4 weeks.

9.3. Guarantees are provided in respect of specified goods supplied by Gledhills as follows:-

(a) Domestic and Commercial Open Vented Cylinders and Tanks.

The storage vessel is guaranteed for ten years and if it proves to be defective either in materials or workmanship, we will either repair or supply replacement at our option with the closest substitute in the case of any obsolete product to any address in Great Britain.

(i) free of all charge during the first year after delivery by us.

(ii) thereafter at a charge of one-tenth of the then current list price and any copper price supplement and delivery charge during the second year after delivery by us and increasing by a further one-tenth on the second and subsequent anniversary of delivery by us.

(b) Domestic Mains Fed Products [Primary Stores]

The storage vessel is guaranteed for five years and if it or any integral pipework as part of the storage vessel assembly proves to be defective either in materials or workmanship, we reserve the right to either repair or supply replacements or the closest possible substitute in the case of any obsolete product and will collect and deliver to any address in England, Wales and Scotland (excluding all Scottish Islands).

(i) free of all charge during the first year after delivery by us.

(ii) thereafter at a charge of one-fifth of the then current list price or any copper price supplement and delivery charge during the second year after delivery by us increasing by a further one-fifth on the second and subsequent anniversary of delivery by us.

(c) StainlessLite Unvented Cylinders

Gledhill guarantee the components including controls, valves and electrical parts for two years from the date of purchase. IT SHOULD BE NOTED THAT THE FACTORY FITTED TEMPERATURE AND PRESSURE RELIEF VALVE MUST NOT BE REMOVED OR ALTERED IN ANY WAY OR THE GUARANTEE WILL NOT BE VALID. GLEDHILL WILL NOT BE RESPONSIBLE FOR ANY CONSEQUENTIAL LOSS OR DAMAGE HOWEVER IT IS CAUSED.

The guarantee for the stainless steel vessel is for twenty five years against material defect or manufacturing faults if the original unit is returned to us AND PROVIDED THAT:

(i) It has not been modified, other than by Gledhill.

(ii) It has not been subjected to wrong or improper use or left uncared for.

(iii) It has only been used for the storage of potable water supplied from the public mains, max 200mg/litre chloride.

(iv) It has not been subjected to frost damage.

(v) The benchmark service record is completed after each annual service.

(vi) The unit has been serviced annually.

(vii) Any disinfection has been carried out strictly in accordance with BS6700.

If the stainless steel vessel proves to be defective either in materials or workmanship we reserve the right to either repair or supply replacements or the closest possible substitute in the case of any obsolete product and will collect and deliver to any address in England, Scotland and Wales (excluding all islands):

(i) free of charge during the first year after delivery by us.

(ii) thereafter at a charge of one twenty fifth of the then current list price during the second year after delivery by us and increasing by a further one twenty fifth on the second and subsequent anniversary of delivery by us.

ACTION IN THE EVENT OF FAILURE

We will require the return of a cylinder which develops a leak for inspection. If our examination confirms a failure then an appropriate level of credit against the cost of the original cylinder will be issued in line with the terms of our warranty.

Please note:

- Installation must have been carried out by a licensed specialized company (heating contractor or plumber) following the version of installation instructions in force.

- Gledhill or its representative was given the opportunity to check complaints on site immediately after any defect occurred.

- Confirmation exists that the system was commissioned properly and that the system was checked and maintenance was performed annually by a specialised company licensed for this purpose.

(d) Components of our products other than Storage Vessels and Integral Pipework.

We will either extend to the purchaser the same terms of warranty as we are given by the manufacturer of the component or if the manufacturer does not give any warranty, replace free of charge any component which becomes defective within two years after the date of the delivery by us and is returned to us at the purchaser's expense but we shall not meet the cost of removal or shipping or return of the component or any other cost charges or damages incurred by the purchaser.

9.4.

9.4.1. In respect of goods supplied by us and in respect of any installation work carried out by or on our behalf, our entire liability and the purchaser's sole remedies (subject to the Guarantees) shall be as follows:-

(a) We accept liability for death or personal injury to the extent that it results from our negligence or that of our employees

- (b) Subject to the other provisions of this clause 9 we accept liability for direct physical damage to tangible property to the extent that such damage is caused by our negligence or that of our employees, agents or subcontractors.
- (c) Our total liability to the purchaser over and above any liability to replace under the Guarantees (whether in contract or in tort including negligence) in respect of any one cause of loss or damage claimed to result from any breach of our obligations hereunder, shall be limited to actual money damages which shall not exceed £20,000 provided that such monetary limit shall not apply to any liability on the part of ourselves referred to in paragraph (a) above
- (d) Except as provided in paragraph (a) above but otherwise notwithstanding any provision herein contained in no event shall we be liable for the following loss or damage howsoever caused and even if foreseeable by us or in our contemplation:-
 - (i) economic loss which shall include loss of profits, business revenue, goodwill or anticipated savings
 - (ii) damages in respect of special indirect or consequential loss or damage (other than death, personal injury and damage to tangible property)
 - (iii) any claim made against the purchaser by any other party (save as expressly provided in paragraph (b) above)
- (e) Except in respect of our liability referred to in paragraph (a) above no claim may be made or action brought (whether in contract or in tort including negligence) by the purchaser in respect of any goods supplied by us more than one year after the date of the invoice for the relevant goods.
- (f) Without prejudice to any other term we shall not be liable for any water damage caused directly or indirectly as a result of any leak or other defect in the goods. We cannot control the conditions of use of the goods or the time or manner or location in which they will be installed and the purchaser agrees to be fully responsible for testing and checking all works which include the goods at all relevant times (up to, including and after commissioning) and for taking all necessary steps to identify any leaks and prevent any damage being caused thereby.
- (g) Nothing in these Conditions shall confer on the purchaser any rights or remedies to which the purchaser would not otherwise be legally entitled

10. LOSS OR INJURY

Notwithstanding any other provision contained herein the purchaser's hereby agree to fully indemnify us against any damages losses costs claims or expenses incurred by us in respect of any claim brought against us by any third party for:-

- (a) any loss injury or damage wholly or partly caused by any goods supplied by us or their use.
- (b) any loss injury or damage wholly or partly caused by the defective installation or substandard workmanship or materials used in the installation of any goods supplied by us.
- (c) any loss injury or damage in any way connected with the performance of this contract.
- (d) any loss resulting from any failure by the purchaser to comply with its obligations under these terms as to install and/or check works correctly.

PROVIDED that this paragraph will not require the purchaser to indemnify us against any liability for our own acts of negligence or those of our employees agents or sub-contractors

FURTHER in the case of goods supplied by us which are re-sold and installed by a third party by the purchaser it will be the sole responsibility of the purchaser to test the goods immediately after their installation to ensure that inter alia they are correctly installed and in proper working order free from leaks and are not likely to cause any loss injury or damage to any person or property.

11. VARIATION OF WARRANTY AND EXCLUSION

Should our warranty and exclusion be unacceptable we are prepared to negotiate for variation in their terms but only on the basis of an increase in the price to allow for any additional liability or risk which may result from the variation. Purchasers are advised to insure against any risk or liability which they may incur and which is not covered by our warranty.

12. ADVICE

Any advice or assistance given by the Company is provided without charge and is in good faith without undertaking, representation or warranty, and we will not accept any liability, whether consequential or compensatory, for advice or assistance given.

13. RISK AND RETENTION OF TITLE

- (a) goods supplied by us shall be at the Purchaser's risk immediately upon delivery to the Purchaser or into custody on the Purchaser's behalf or to the Purchaser's Order. The Purchaser shall effect adequate insurance of the goods against all risks to the full invoice value of the goods, such insurance to be effective from the time of delivery until property in the goods shall pass to the Purchaser as hereinafter provided.
- (b) property in the goods supplied hereunder will pass to the Purchaser when full payment has been made by the Purchaser to us for :-
 - (i) the goods of the subject of this contract.
 - (ii) all other goods the subject to of any other contract between the Purchaser and us which, at the time of payment of the full price of the goods sold under this contract, have been delivered to the Purchaser but not paid for in full.
- (c) until property in the goods supplied hereunder passes to the Purchaser in accordance with paragraph (2) above.
 - (i) the Purchaser shall hold the goods in a fiduciary capacity for us and shall store the same separately from any other goods in the Purchaser's possession and in a manner which enables them to be identified as our goods.
 - (ii) the Purchaser shall immediately return the goods to us should our authorised representative so request. All the necessary incidents associated with a fiduciary relationship shall apply.
- (d) the Purchaser's right to possess the goods shall cease forthwith upon the happening of any of the following events, namely :-
 - (i) if the Purchaser fails to make payment in full for the goods within the time stipulated in clause 4 hereof.
 - (ii) if the Purchaser, not being a company, commits any act of bankruptcy, makes a proposal to his or her creditors for a compromise or does anything which would entitle a petition for a Bankruptcy Order to be presented.
 - (iii) if the Purchaser, being a company, does anything or fails to do anything which would entitle an administrator or an administrative receiver or a receiver to take possession of any assets or which would entitle any person to present a petition for winding up or to apply for an administration order.
- (e) the Purchaser hereby grants to us an irrevocable licence to enter at any time any vehicle or premises owned or occupied by the Purchaser or in the possession of the Purchaser for the purposes of repossessing and recovering any such goods the property in which has remained in us under paragraph (2) above. We shall not be responsible for and the Purchaser will indemnify us against liability in respect of damage caused to

any vehicle or premises in such repossession and removal being damaged which it was not reasonably practicable to avoid.

- (f) notwithstanding paragraph (3) hereof and subject to paragraph (7) hereof, the Purchaser shall be permitted to sell the goods to third parties in the normal course of business. In this respect the Purchaser shall act in the capacity of our commission agent and the proceeds of such sale :-
 - (i) shall be held in trust for us in a manner which enables such proceeds to be identified as such, and;
 - (ii) shall not be mixed with other monies nor paid into an overdrawn bank account.
- (g) in the event that the Purchaser shall sell any of the goods pursuant to clause (6) hereof, the Purchaser shall forthwith inform us in writing of such sale and of the identity and address of the third party to whom the goods have been sold.
- (h) if, before property in the goods passes to the Purchaser under paragraph (2) above the goods are or become affixed to any land or building owned by the Purchaser it is hereby agreed and declared that such affixation shall not have the effect of passing property in the goods to the Purchaser. Furthermore if, before property in the goods shall pass to the Purchaser under paragraph (2) hereof, the goods are or become affixed to any land or building (whether or not owned by the Purchaser), the Purchaser shall:-
 - (i) ensure that the goods are capable of being removed without material injury to such land or building.
 - (ii) take all necessary steps to prevent title to the goods from passing to the landlord of such land or building.
 - (iii) forthwith inform us in writing of such affixation and of the address of the land or building concerned.

We, as principal, shall remunerate the Purchaser as commission agent a commission depending upon the surplus which the Purchaser can obtain over and above the sum, stipulated in this contract of supply which will satisfy us.

The Purchaser warrants to repair and make good any damage caused by the affixation of the goods to or their removal from any land or building and to indemnify us against all loss damage or liability we may incur or sustain as a result of affixation or removal.

- (i) in the event that, before property in the goods has passed to the Purchaser under paragraph (2) hereof, the goods or any of them are lost, stolen, damaged or destroyed :-
- (ii) the Purchaser shall forthwith inform us in writing of the fact and circumstances of such loss, theft, damage or destruction.
- (iii) the Purchaser shall assign to us the benefit of any insurance claim in respect of the goods so lost, stolen, damaged or destroyed.

14. NON-PAYMENT

If the Purchaser shall fail to make full payment for the goods supplied hereunder within the time stipulated in clause 4 hereof or be in default of payment for any other reason then, without prejudice to any of our other rights hereunder, we shall be entitled to stop all deliveries of goods and materials to the Purchaser, including deliveries or further deliveries of goods under this contract. In addition we shall be entitled to terminate all outstanding orders.

15. VALUE ADDED TAX

All prices quoted are exclusive of Value Added Tax which will be charged at the rate ruling at the date of despatch of invoice.

16. TRADE SALES ONLY

We are only prepared to deal with those who are not consumers within the terms of the Unfair Contract Terms Act 1977, the Sale of Goods Act 1979 and the Supply of Goods and Services Act 1982. Accordingly any person who purchases from us shall be deemed to have represented that he is not a consumer by so purchasing.

17. JURISDICTION

The agreement is subject to English law for products delivered in England and Scottish law for products delivered in Scotland and any dispute hereunder shall be settled in accordance therewith dependent upon the location.

18. PRODUCT DEVELOPMENT

Gledhill have a policy of continuous product development and may introduce product modifications from time to time.

MAINS PRESSURE HOT WATER STORAGE SYSTEM COMMISSIONING CHECKLIST

This Commissioning Checklist is to be completed in full by the competent person who commissioned the storage system as a means of demonstrating compliance with the appropriate Building Regulations and then handed to the customer to keep for future reference.

Failure to install and commission this equipment to the manufacturer's instructions may invalidate the warranty but does not affect statutory rights.

Customer name:										Telephone number:														
Address:																								
Cylinder Make and Model																								
Cylinder Serial Number																								
Commissioned by (PRINT NAME):										Registered Operative ID Number														
Company name:										Telephone number:														
Company address:																								
										Commissioning date:														
To be completed by the customer on receipt of a Building Regulations Compliance Certificate*:																								
Building Regulations Notification Number (if applicable)																								
ALL SYSTEMS PRIMARY SETTINGS (indirect heating only)																								
Is the primary circuit a sealed or open vented system?										Sealed					Open									
What is the maximum primary flow temperature?										°C														
ALL SYSTEMS																								
What is the incoming static cold water pressure at the inlet to the system?										bar														
Has a strainer been cleaned of installation debris (if fitted)?										Yes					No									
Is the installation in a hard water area (above 200ppm)?										Yes					No									
If yes, has a water scale reducer been fitted?										Yes					No									
What type of scale reducer has been fitted?																								
What is the hot water thermostat set temperature?										°C														
What is the maximum hot water flow rate at set thermostat temperature (measured at high flow outlet)?										l/min														
Time and temperature controls have been fitted in compliance with Part L of the Building Regulations?										Yes														
Type of control system (if applicable)										Y Plan					S Plan					Other				
Is the cylinder solar (or other renewable) compatible?										Yes					No									
What is the hot water temperature at the nearest outlet?										°C														
All appropriate pipes have been insulated up to 1 metre or the point where they become concealed										Yes														
UNVENTED SYSTEMS ONLY																								
Where is the pressure reducing valve situated (if fitted)?																								
What is the pressure reducing valve setting?										bar														
Has a combined temperature and pressure relief valve and expansion valve been fitted and discharge tested?										Yes					No									
The tundish and discharge pipework have been connected and terminated to Part G of the Building Regulations																								
Are all energy sources fitted with a cut out device?										Yes					No									
Has the expansion vessel or internal air space been checked?										Yes					No									
THERMAL STORES ONLY																								
What store temperature is achievable?										°C														
What is the maximum hot water temperature?										°C														
ALL INSTALLATIONS																								
The hot water system complies with the appropriate Building Regulations										Yes														
The system has been installed and commissioned in accordance with the manufacturer's instructions										Yes														
The system controls have been demonstrated to and understood by the customer										Yes														
The manufacturer's literature, including Benchmark Checklist and Service Record, has been explained and left with the customer										Yes														
Commissioning Engineer's Signature																								
Customer's Signature																								
(To confirm satisfactory demonstration and receipt of manufacturer's literature)																								

*All installations in England and Wales must be notified to Local Authority Building Control (LABC) either directly or through a Competent Persons Scheme. A Building Regulations Compliance Certificate will then be issued to the customer.



© Heating and Hotwater Industry Council (HHIC)

www.centralheating.co.uk

While this Checklist can be used for any installation covered by its description, only appliances manufactured by Scheme Members will be covered by the rules and requirements of the Benchmark Scheme.

SERVICE RECORD

It is recommended that your hot water system is serviced regularly and that the appropriate Service Record is completed.

Service Provider

Before completing the appropriate Service Record below, please ensure you have carried out the service as described in the manufacturer's instructions.

SERVICE 01		Date:	SERVICE 02		Date:
Engineer name:		Engineer name:		Engineer name:	
Company name:		Company name:		Company name:	
Telephone No:		Telephone No:		Telephone No:	
Comments:		Comments:		Comments:	
.....		
.....		
.....		
.....		
Signature		Signature		Signature	
SERVICE 03		Date:	SERVICE 04		Date:
Engineer name:		Engineer name:		Engineer name:	
Company name:		Company name:		Company name:	
Telephone No:		Telephone No:		Telephone No:	
Comments:		Comments:		Comments:	
.....		
.....		
.....		
.....		
Signature		Signature		Signature	
SERVICE 05		Date:	SERVICE 06		Date:
Engineer name:		Engineer name:		Engineer name:	
Company name:		Company name:		Company name:	
Telephone No:		Telephone No:		Telephone No:	
Comments:		Comments:		Comments:	
.....		
.....		
.....		
.....		
Signature		Signature		Signature	
SERVICE 07		Date:	SERVICE 08		Date:
Engineer name:		Engineer name:		Engineer name:	
Company name:		Company name:		Company name:	
Telephone No:		Telephone No:		Telephone No:	
Comments:		Comments:		Comments:	
.....		
.....		
.....		
.....		
Signature		Signature		Signature	
SERVICE 09		Date:	SERVICE 10		Date:
Engineer name:		Engineer name:		Engineer name:	
Company name:		Company name:		Company name:	
Telephone No:		Telephone No:		Telephone No:	
Comments:		Comments:		Comments:	
.....		
.....		
.....		
.....		
Signature		Signature		Signature	

Protect your Gledhill product after your initial warranty period



On expiry of your initial warranty period, Gledhill Response Limited would be pleased to provide further customer support with a range of services including:

Low cost annual repair and maintenance contracts direct from Gledhill

Annual servicing and safety checks

Expert response to 'out of warranty' breakdowns at fixed charges

Please call 08445 679898 or visit www.gledhill.net for further details



For any spare part requirements on this product simply scan the QR code using your smart phone app or go to www.gledhill-spares.net



Gledhill Building Products Limited

Sycamore Estate, Squires Gate, Blackpool FY4 3RL Tel: 01253 474550 Fax: 01253 474551 sales@gledhill.net
After Sales Technical Support Tel: 01253 474584

Gledhill Building Products produce cylinders for use with a wide range of heat sources including;

Gas and oil boilers
Ground source heat pumps

Electricity
Solar energy

Air source heat pumps
Wood burning stoves

Further information on Gledhill products can be found at www.gledhill.net



To protect our environment, we use copper a totally recyclable metal, which never becomes waste.



FM 02057



THE MARK OF QUALITY FOR THE INSTALLATION, COMMISSIONING AND SERVICING OF DOMESTIC HEATING AND HOT WATER SYSTEMS



CHARTER MEMBER



Due to a programme of continuous improvement Gledhill Building Products reserve the right to modify products without prior notice. It is advisable to check the product technical detail by using the latest design and installation manuals available from our technical support team or on our website. It is an offence to copy or adapt this document without consent of the owner.