

StainlessLite HP

Unvented cylinders specifically designed to work with a heat pump

Design, Installation & Servicing Instructions



Models covered in this manual

- Stainless Lite HP SOL Indirect 180-400 litres
- Stainless Lite HP Indirect 180-400 litres
- Stainless Lite HP Slimline 180-210 litres

These instructions should be read in conjunction with the installation/servicing instructions issued by the manufacturer of the heat source being used.

Any installation must be in accordance with the relevant requirements of the Gas Safety Regulations, Building Regulations, I.E.E. Wiring Regulations and the Water Fitting Regulations (England and Wales) or Water Byelaws (Scotland). It should be read in accordance with the relevant recommendations of the following:

BS 6798; BS EN 12828, BS EN 12831, BS EN 14336; BS 5546;
BS 5440:1; BS 5440:2; CP 331:3
BS EN 806-1 to 5, BS EN 8558:2011; BS EN 1458-1:2011 and BS 7593:2006

Stainless Lite is covered by Section G3 of the Building Regulations (England and Wales) Technical Standard P3 (Scotland) and Building Regulation P5 (Northern Ireland). Compliance can be achieved via a Competent Person Self Certification Scheme or notification of installation to the Local Authority Building Control Department.

It must be installed by a competent person as defined by the relevant regulations. Manufacturers notes must NOT be taken as over-riding statutory obligations.

This appliance is not intended for use by persons (including children) with reduced physical, sensory or mental capabilities, or lack of experience and knowledge unless they have been given supervision or instruction concerning use of the appliance by a person responsible for their safety. Children should be supervised at all times to ensure they do not play with the appliance.

This information is provided to assist generally in the selection of equipment. Responsibility for selection and specification of our equipment must however remain that of our customer and any experts or consultants concerned with the installation(s).

Please note: that we do not therefore accept any responsibility for matters of design selection or specification, for the effectiveness of an installation or system containing one of our products unless specifically requested to do so in writing.

All goods are sold subject to our Conditions of Sale which are set out at the rear of this specification. In the interest of continuously improving the Stainless Lite range, Gledhill Building Products Limited reserve the right to modify the product without notice, and in these circumstances this booklet, which is accurate at the time of printing, should be disregarded. An updated set of Instructions will be produced and supplied with new appliances and will be made available for other appliances on request.

Stainless Lite is produced under an ISO 9001:2008 Quality Management System approved by BSI.



Benchmark places responsibilities on both manufacturers and installers. The purpose is to ensure that customers are provided with the correct equipment for their needs, that it is installed, commissioned and serviced in accordance with the manufacturers instructions by competent persons and that it meets the requirements of the appropriate Building Regulations. The Benchmark Checklist can be used to demonstrate compliance with Building Regulations and should be provided to the customer for future reference.

Installers are required to carry out installation, commissioning and servicing work in accordance with the Benchmark Code of Practice which is available from the Heating and Hot Water Industry Council who manage and promote the Scheme. Visit www.centralheating.co.uk for more information.

For further information on the HWA Charter Membership, please refer to the HWA website hotwater.org.uk.

ISSUE 11: SEPTEMBER 2014

Section	Page
DESIGN	
Description	3
Technical Information	5
System Design	7
INSTALLATION	
Installation	11
Commissioning	22
USER INSTRUCTIONS	23
SERVICING AND MAINTENANCE	
Servicing and Maintenance	24
Fault Finding	25
Short Parts List	27
APPENDIX	
Appendix A	28
Appendix B	29
Notes	30
Terms & Conditions	32
Benchmark Checklist	34
Benchmark Service Record	35

Manufacturer: Gledhill Building Products Ltd

Maximum inlet pressure to Pressure reducing valve	12 bar
Operating pressure (PRV setting)	3 bar
Expansion vessel charge pressure	3 bar
Expansion relief valve setting	4.75 bar
Opening pressure of P & T Relief Valve	6 bar
Opening temperature of P & T Relief Valve	92-95°C
Energy cut-out thermostat setting	85°C
Max. working pressure - Primary heat exchanger (Indirect models)	6 bar
Max. working pressure - Solar heat exchanger (Solar models)	10 bar
Immersion heater rating	3kW, 240V AC

All cylinders are manufactured in accordance with the requirements of BS EN 12897. The tundish must be positioned so that it is visible to the occupant and is away from electrical devices.

Components supplied with Stainless Lite:

- Cold water inlet PRV combination valve/expansion relief
- Lift up pressure and temperature relief valve
- Control thermostat
- Energy cut-out thermostat
- Energy cut-out motorised valve (indirects only)
- Tundish
- 3kW Immersion heater including control and cut out thermostats
- Expansion vessel/mounting bracket/flexible hose
- Technical/user product literature

In any situation where the volume of heated pipework (eg. secondary circulation pipes or manifold pipework for multiple units) exceeds 10 litres, then an additional expansion vessel must be fitted to accommodate the extra expansion volume.

Handling Before Installation

Stainless Lite must be handled with care and stored the correct way up in a dry place. Any manual handling/lifting operations will need to comply with the requirements of the Manual Handling Operations Regulations issued by the H.S.E. The appliance can be moved using a sack truck on the rear face although care should be taken and the route should be even. In apartment buildings containing a number of storeys we would recommend that the appliances are moved vertically in a mechanical lift. If it is proposed to use a crane, expert advice should be obtained regarding the need for slings, lifting beams etc.

A specific manual handling assessment is shown in Appendix B at the rear of this manual.

Maintenance

Modifications should not be made to this product. Replacement parts, including immersion heaters, should be purchased from Gledhill Building Products Limited, or agents approved by them. Unvented hot water storage vessels need regular routine checks, and these are detailed below. It is for this reason that this manual must always be left with the Stainless Lite.

It is essential that these checks be carried out at the time of boiler maintenance by a qualified installer:

1. Manually open the relief valves in turn, and check that water is discharged from the valves and runs freely through the tundish and out at the discharge point. Ensure that the valves re-seat satisfactorily. (Note - the water may be very hot).
2. It is important to check that the discharge pipework is carrying the water away adequately. Check for blockages etc. if it is not.
3. Turn the mains water off and remove and clean the strainer element in the Pressure Reducing Valve.
4. Check the charge pressure in the expansion vessel and repressurise if required
5. Re-fill the system and ensure that all relief valves have re-seated.
6. The Benchmark Service Record should be updated at each service.
7. Check the water pressure downstream of the combination valve is bar in static condition.
8. Check and if necessary, descale the heat exchanger in hard water areas ie. above 200ppm (mg/l).

Note:

The cylinder is factory fitted with a temperature & pressure relief valve that must not be used for any other purpose or removed.

The cylinder is factory fitted with immersion heaters with thermal cut outs. Immersions without thermal cut outs must not be fitted.

DESIGN

Table 1

Stainless Lite HP SOL Model			HP180INDSOL	HP210INDSOL	HP250INDSOL	HP300INDSOL	HP400INDSOL
Capacity - total volume		litres	180	210	250	300	400
Volume heated by IH		litres	113	135	160	195	270
Dedicated solar volume		litres	65	75	90	105	130
Standing heat loss rate		kWh/24h	1.48	1.70	1.85	2.04	2.82
Weight - empty/full		kg	33/213	38/248	43/293	49/349	61/461
Pressure regulating valve setting		bar	3	3	3	3	3
Expansion relief valve setting		bar	4.75	4.75	4.75	4.75	4.75
Temperature setting (P&T valve)		°C	95	95	95	95	95
Pressure setting (P&T valve)		bar	6.0	6.0	6.0	6.0	6.0
Expansion vessel size (volume)		litres	18	24	24	35	2 x 24
Expansion vessel initial charge pressure		bar	3	3	3	3	3
Height	A	mm	1305	1495	1745	1992	2030
Diameter	B	mm	550	550	550	550	630
22mm secondary return	C	mm	-	1127	1377	1577	1592
22mm compression cold feed	D	mm	442	442	522	522	557
P & T valve	E	mm	1053	1241	1491	1720	1784
22mm solar return - bottom coil	F	mm	223	223	223	223	238
22mm solar flow - bottom coil	G	mm	352	352	472	472	548
28mm primary return - top coil	H	mm	467	542	647	742	641
28mm primary flow - top coil	I	mm	1072	1232	1467	1562	1791
Dual CT & OHT pocket - 1 top	J	mm	732	837	962	1092	1076
Dual CT & OHT pocket - 2 bottom	K	mm	419	419	539	539	651
Solar sensor pocket - 1 top	L	mm	882	1000	1180	1367	1382
Solar sensor pocket - 2 bottom	M	mm	203	203	262	262	334
3kW immersion heater height	N	mm	457	522	607	702	640
Surface area of solar heater coil		m ²	0.68	0.68	0.97	0.97	1.27
Solar coil pressure loss ¹		bar	0.191	0.191	0.241	0.241	0.31
Primary heat exchanger surface area		m ²	1.36	1.56	1.94	2.04	2.91
Primary heat exchanger thermal rating ¹		kW	24.3	26.2	27.5	34.2	47.2
Primary heat exchanger pressure loss ¹		bar	0.048	0.054	0.060	0.019	0.027
Heat up time from 15°C to 60°C ²		min	33	41	44	48	49
Recovery time after 70% draw-off ²		min	21	26	30	32	38

1. Measured at 0.25 l/s primary flow rate

2. Measured at 0.25 l/s primary flow rate and at 82°C flow temperature

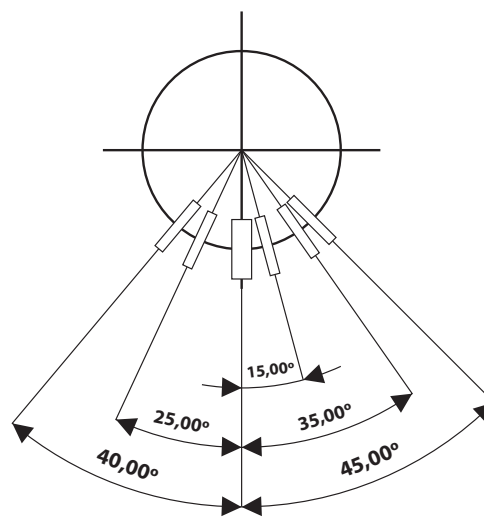
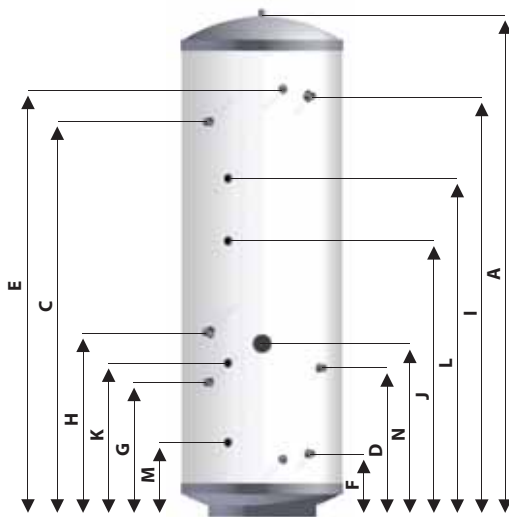

NOTES

1. Not all models - see table 1.
2. Recovery times based on Primary Coil/I.H. duty (ie. assumes the heat pump / solar output is adequate).
3. All connections are supplied with compression fittings for direct connection to copper pipework.

Table 2

StainlessLite HP Model			HP180IND	HP210IND	HP250IND	HP300IND	HP400IND
Capacity - total volume		litres	171	212	251	292	390
Volume heated by IH		litres	158	199	238	279	372
Standing heat loss rate		kWh/24h	1.48	1.70	1.85	2.04	2.82
Weight - empty/full		kg	33/204	38/250	43/294	58/350	62/452
Pressure regulating valve setting		bar	3	3	3	3	3
Expansion relief valve setting		bar	4.75	4.75	4.75	4.75	4.75
Temperature setting (P&T valve)		°C	95	95	95	95	95
Pressure setting (P&T valve)		bar	6.0	6.0	6.0	6.0	6.0
Expansion vessel size (volume)		litres	18	24	24	35	2 x 24
Expansion vessel initial charge pressure		bar	3	3	3	3	3
Height		mm	1305	1493	1743	1990	2030
Diameter		mm	550	550	550	550	630
Hot Supply	A	mm	1352	1540	1790	2035	2080
P & T valve	B	mm	1047	1235	1485	1731	1784
22mm secondary return	C	mm	-	1127	1377	1577	1577
28mm primary flow	D	mm	1043	1230	1250	1270	1660
Control stat	E	mm	440	494	577	677	668
28mm primary return	F	mm	273	260	280	300	330
Cold feed	G	mm	258	258	258	258	285
3kW immersion heater	H	mm	217	217	217	217	245
Primary heat exchanger surface area ¹		m ²	2.5	3	3	3	4
Primary heat exchanger thermal rating ¹		kW	16.74	17.91	15.93	13.18	18.87
Primary heat exchanger pressure loss ¹		bar	0.04	0.05	0.06	0.05	0.07
Heat up time from 15°C to 50°C ²		min	18.02	20.47	31.57	42.5	37.1
Average domestic hot water temperature ¹		min	46.95	46.77	48.44	42.06	47.32

1. Measured at 0.25 l/s primary flow rate 2. Measured at 0.25 l/s primary flow rate and at 55°C flow temperature

NOTES

1. Recovery times base on Primary Coil/I.H. duty (ie. assumes the heat pump output is adequate).

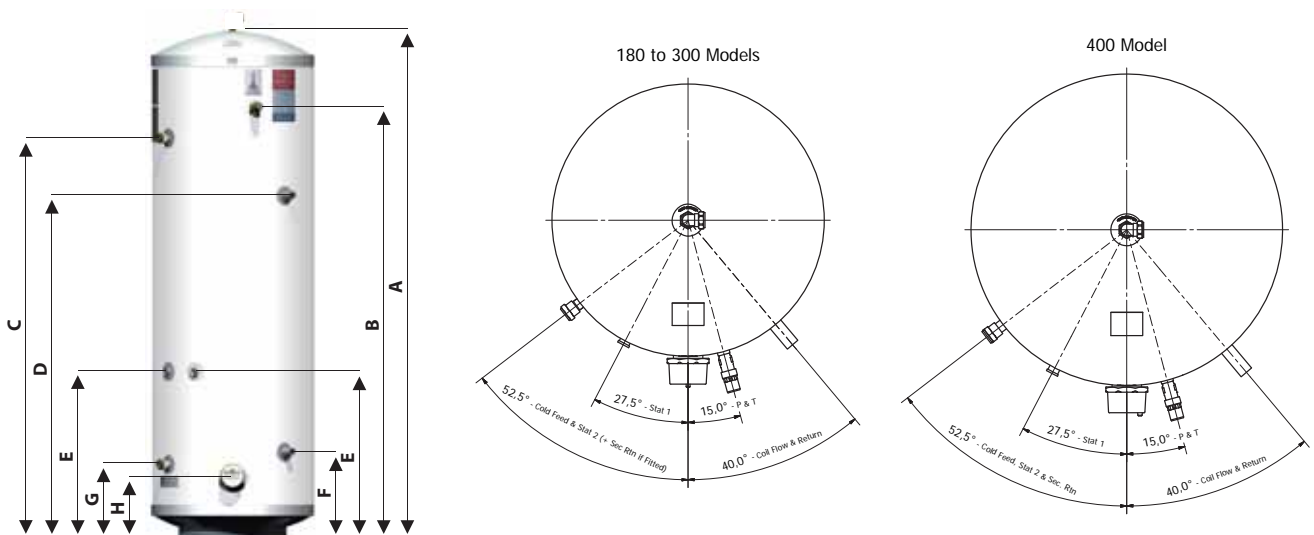

DESIGN

Table 3

Stainless Lite HP Slimline Model			HP180SL	HP210SL
Capacity - total volume		litres	180	210
Volume heated by IH		litres	170	200
Dedicated solar volume		litres	-	-
Standing heat loss rate		kWh/24h	2.01	2.23
Weight - empty/full		kg	33/213	37/247
Pressure regulating valve setting		bar	3	3
Expansion relief valve setting		bar	4.75	4.75
Temperature setting (P&T valve)		°C	95	95
Pressure setting (P&T valve)		bar	6.0	6.0
Expansion vessel size (volume)		litres	18	24
Expansion vessel initial charge pressure		bar	3	3
Height	A	mm	1790	1970
Diameter	B	mm	475	475
22mm secondary return	C	mm	-	1540
22mm compression cold feed	D	mm	283	283
P & T valve	E	mm	1535	1706
22mm solar return	F	mm	-	-
22mm solar flow	G	mm	-	-
28mm primary return	H	mm	275	285
28mm primary flow	I	mm	1545	1585
HP control thermostat	J	mm	628	699
Dual CT & OHT pocket	K	mm	628	699
Solar sensor pocket - 1 top	L	mm	-	-
Solar sensor pocket - 2 bottom	M	mm	-	-
3kW immersion heater height	N	mm	207	212
Surface area of solar heater coil		m ²	-	-
Solar coil pressure loss ¹		bar	-	-
Primary heat exchanger surface area		m ²	3.01	3.01
Primary heat exchanger thermal rating ¹		kW	32.8	31.2
Primary heat exchanger pressure loss ¹		bar	0.018	0.018
Heat up time from 15°C to 60°C ²		min	33	41
Recovery time after 70% draw-off ²		min	21	26

1. Measured at 0.25 l/s primary flow rate

2. Measured at 0.25 l/s primary flow rate and at 82°C flow temperature

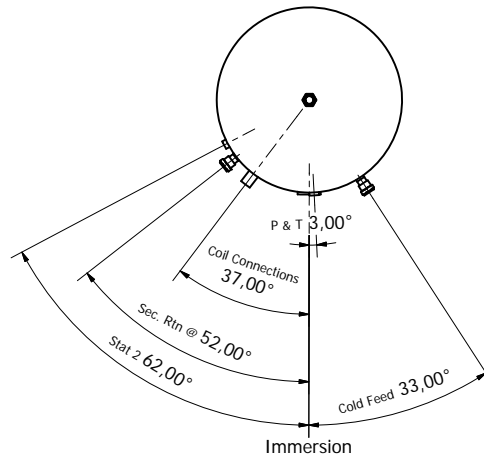
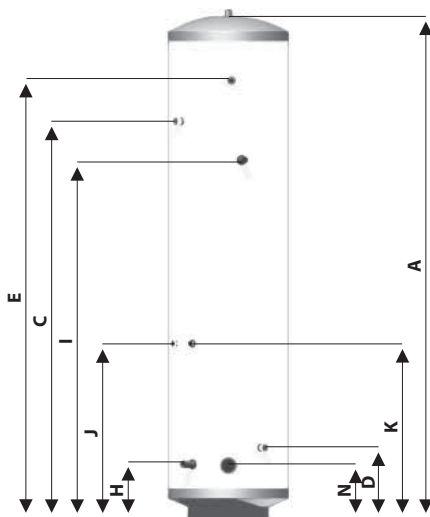

NOTES

1. Not all models - see table 2.
2. Recovery times based on Primary Coil/I.H. duty (ie. assumes the heat pump output is adequate).
3. All connections are supplied with compression fittings for direct connection to copper pipework.

DESIGN

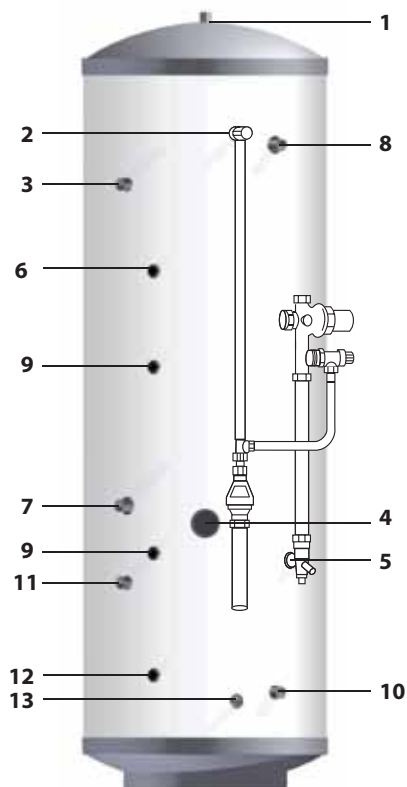

Typical arrangement of component kit shown fitted to the appliance for clarity
Pipework to be supplied and fitted by installer.

Stainless Lite HP SOL

Basic Appliance

1. Hot water draw off (22mm) compression
2. Lift up temperature & pressure relief valve 92-95°/6 bar
3. Hot water secondary return 22mm (not fitted to smaller sizes, see table 1)
4. Immersion heater 1 $\frac{3}{4}$ " BSP 3kW
5. 22mm cold supply
6. Thermostat pocket (22mm)
7. Primary return (28mm)
8. Primary flow (28mm)
9. Dual control/Overheat stat & solar thermostat pocket
10. Solar coil return to panel collector (22mm) compression
11. Solar coil flow from panel (22mm) compression
12. Solar thermostat pocket
13. Drain off

Part G3 loose components supplied in a separate box'

- A. Combination inlet group incorporating pressure reducing valve, strainer, check valve, balance cold take off point, expansion relief valve and expansion vessel connection points.
- B. Potable expansion vessels c/w flexible hose and wall bracket
- C. Tundish
- D. Dual control thermostat and combined overheat thermostat (x2)
- E. Two port (28mm) zone valve for primary circuit
- F. Wiring junction box for primary system

DESIGN

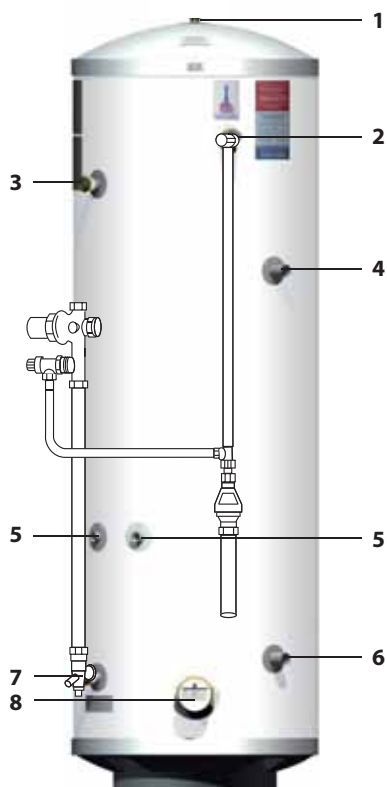

Stainless Lite HP

Basic Appliance

1. Hot water draw off (22mm compression)
2. Lift up temperature & pressure relief valve (1/2" female)
3. Hot water secondary return (22mm compression) (not fitted to smaller sizes, see table 1)
4. Primary flow (28mm plain pipe)
5. Control stat
6. Primary return (28mm plain pipe)
7. Cold feed (22mm compression)
8. Immersion heater 1 3/4" BSP 3kW

Part G3 loose components supplied in a separate box'

- A. Combination inlet group incorporating pressure reducing valve, strainer, check valve, balance cold take off point, expansion relief valve and expansion vessel connection points.
- B. Potable expansion vessels c/w flexible hose and wall bracket
- C. Tundish
- D. Dual control thermostat and combined overheat thermostat
- E. Two port (28mm) zone valve for primary circuit
- F. Wiring junction box for primary system

Typical arrangement of component kit shown fitted to the appliance for clarity
Pipework to be supplied and fitted by installer.

DESIGN

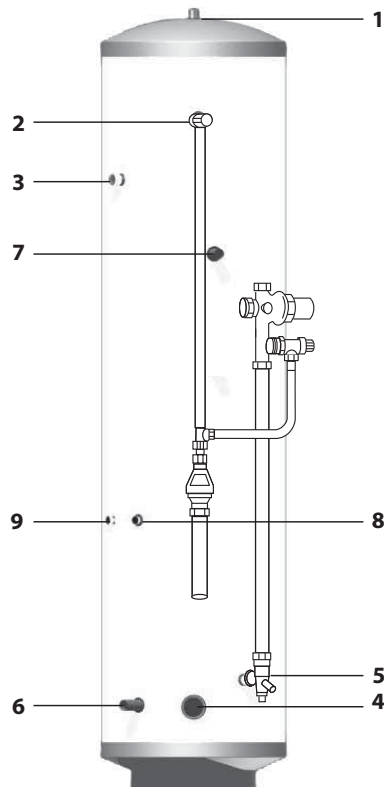

Stainless Lite HP Slimline

Basic Appliance

1. Hot water draw off (22mm) compression
2. Lift up temperature & pressure relief valve 92-95°/6 bar
3. Hot water secondary return 22mm (210 litre model only)
4. Immersion heater 1¾" BSP 3kW
5. 22mm cold supply
6. Primary return (28mm)
7. Primary flow (28mm)
8. Dual control/Overheat stat
9. HP control thermostat

Part G3 loose components supplied in a separate box'

- A. Combination inlet group incorporating pressure reducing valve, strainer, check valve, balance cold take off point, expansion relief valve and expansion vessel connection points.
- B. Potable expansion vessels c/w flexible hose and wall bracket
- C. Tundish
- D. Dual control thermostat and combined overheat thermostat
- E. Two port (28mm) zone valve for primary circuit
- F. Wiring junction box for primary system

Typical arrangement of component kit shown fitted to the appliance for clarity
Pipework to be supplied and fitted by installer.

Stainless Lite is a range of unvented hot water storage cylinders, manufactured in the latest high quality duplex stainless steel. They are designed to provide mains pressure hot water and are supplied as a package which complies with Section G3 of the Building Regulations. The appliance is extremely well insulated using high density HCFC free foam insulation with an ozone depleting potential (ODP) of zero and a global warming potential (GWP) of 1. It is fitted with all necessary safety devices and supplied with all the necessary control devices to make installation on site as easy as possible.

Stainless Lite Heat Pump (HP) SOL models:

The Stainless Lite HP SOL is an unvented hot water storage cylinder fitted with two high efficiency internal primary heat exchangers especially designed for use with heat pump systems. These two heat exchangers **must** be connected in parallel to the heat pump circuit when a solar thermal system is not installed, as shown in the schematic on page 16. When both heat pump and solar thermal systems are installed, the top heat exchanger is connected to the heat pump circuit and the bottom heat exchanger is connected to the solar circuit as shown in figure 2.

All Stainless Lite HP SOL models are fitted with 3kW (230Vac, 50Hz) immersion heater for raising the temperature of the stored water to above 60°C after the heat pump heating cycle if necessary. During commissioning the actual temperature that the cylinder reaches when the thermostat(s) operate should be tested and adjusted so that it achieves a minimum of 60°C in order to comply with the Legionella pasteurisation requirements. The technical details of the Stainless Lite HP models are listed in table 1.

Important notes:

1. All Stainless Lite HP models are suitable for both open vented and sealed primary systems.
2. When used with a sealed primary heating system, the heat pump must incorporate its own over heat thermostat.
3. Stainless Lite HP models must not be used with solid fuel boilers or steam as the heat source.
4. Heat pumps can normally only heat the domestic hot water to between 45 – 50°C, therefore provision should be made to periodically heat the cylinder to above 60°C to prevent growth of legionella.
5. The cold supply elbow c/w drain tapping must be fitted as shown in figures 1 & 2. A flexible hose can then be connected to the drain tapping and providing the hose runs below the lowest level of the cylinder, then all the water content can be drained out by the syphonic action.

Stainless Lite Heat Pump (HP) and Slimline models:

The Stainless Lite HP and Slimline cylinders unvented hot water storage cylinders fitted with a high efficiency coil. The coil has a low pressure loss due to it being a multiple pass coil which enable high flow rates to be achieved through it. In addition due to the coil being corrugated the heat transfer rate is higher than that of plain tube coil. The cylinder has been specifically designed for heat pump applications. It incorporates an immersion heater at the base of the unit which enables pasteurisation of the water. This should be done on a regular basis in line with HWA guidance..

The slimline has been designed to enable it to fit into tighter locations.

INSTALLATION

General Design Considerations

The cupboard footprint needs to be at least 650mm square for units up to 300 litres, 730mm for 400 litre units.

The base chosen for the cylinder should be level and capable of supporting the weight of the unit when full of water as shown in General Data. The discharge pipework for the safety valves must have a minimum fall of 1 : 200 from the unit to a safe discharge point. All exposed pipework and fittings on the cylinder should be insulated, and the unit should NOT be fixed in a location where the contents could freeze.

In new systems, pipes should be insulated to comply with building regs, the maximum permissible heat loss is indicated in the table opposite, and labelled accordingly as follows:

- i. Primary circulation pipes for domestic hot water circuits should be insulated through their length, subject only to practical constraints imposed by the need to penetrate joists and other structural elements.
- ii. All pipes connected to hot water storage vessels, including the vent pipe, should be insulated for at least 1 metre from their points of connection to the cylinder (or they should be insulated up to the point where they become concealed).

In replacement systems, whenever a boiler or hot water storage vessel is replaced in an existing system, any pipes that are exposed as part of the work or are otherwise accessible should be insulated as recommended for new systems, or to some lesser standard where practical constraints dictate.

The pipe connecting the boiler flow to the appliance must not be less than 22mm copper or equivalent.

Insulation of pipework	
Pipe outside diameter	Maximum heat loss
15mm	7.89W/m
22mm	9.12W/m
28mm	10.07W/m
35mm	11.08W/m

Further guidance on converting heat loss limits to insulation thickness for specific thermal conductivities is available in TIMSA "HVAC guidance for achieving compliance with Part L of the Building Regulations".

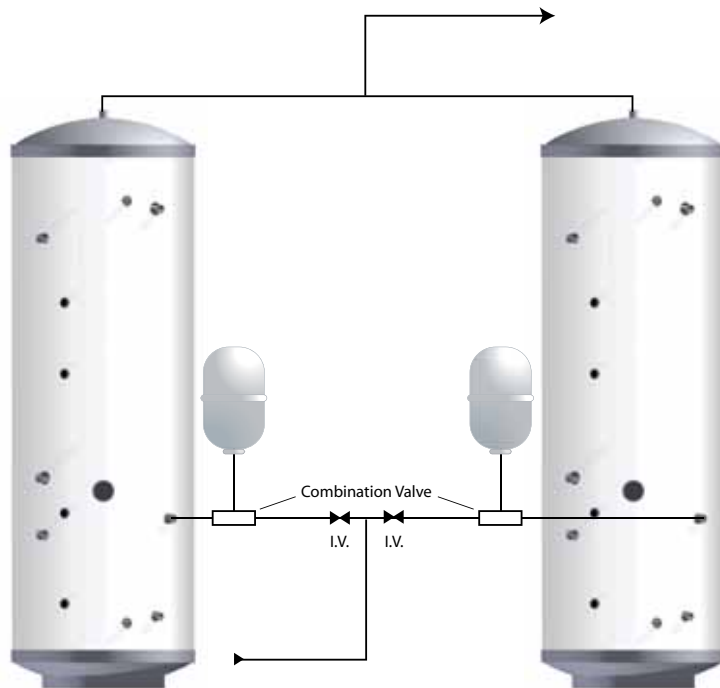

If two Stainless Lites are coupled together the secondary inlet and outlet pipes must be balanced. The units must be fitted on the same level.

Note: No valves must be fitted between the expansion vessel and the storage cylinder(s).

Mains Water Supply

Existing properties with a 15mm supply will be satisfactory provided the local mains pressure is good, but should be confined to single bathroom properties. For new properties where simultaneous demand is required to more than one bathroom or a bathroom and one or more en-suites, the communication and service pipe into the dwelling should be a minimum of 22mm (usually in the form of a 25mm MDPE supply). The optimum performance is achieved if the inlet pressure is 3 bar dynamic. However, the Stainless Lite will function with lower inlet pressures, but this will reduce the performance. There should be a flow of at least 30 litres per minute or above available into the property. Normally Stainless Lite provides well in excess of 40 litres/min in most conditions. Flow rates for ALL mains pressure systems are subject to district pressures and system dynamic loss. Particularly on larger properties with more than one bathroom, the pipe sizes should be calculated in accordance with BS EN 806-3:2006 and BS 8558:2011.

INSTALLATION

Stainless Lite HP SOL and HP Model Selection Guide			
Dwelling type		Suggested model	
Number of bedrooms	Number of bathrooms and shower rooms	Without solar heating system ⁽¹⁾	With solar heating system ⁽²⁾
1-3	1 bathroom	HP180INDSOL HP180IND	HP180INDSOL (F _A = 50m ²)
2-3	1 bathroom + 1 shower room	HP180INDSOL HP180IND	HP210INDSOL (F _A = 65m ²)
2-3	1 bathroom + 2 shower rooms	HP180INDSOL HP180IND	HP250INDSOL (F _A = 85m ²)
2-4	2 bathrooms + 1 shower room	HP210INDSOL HP210IND	HP300INDSOL (F _A = 110m ²)
2-4	2 bathrooms + 2 shower rooms	HP250INDSOL HP250IND	HP400INDSOL (F _A = 150m ²)
3-5	2 bathrooms + 2 shower rooms	HP300INDSOL HP300IND	–
4-5	2 bathrooms + 3 shower rooms	HP400INDSOL HP400IND	–

Notes

- Where solar model selected, both top and bottom heat exchangers connected to heat pump circuit
- Top heat exchanger connected to heat pump circuit and bottom heat exchanger connected to solar circuit.
- F_A = Maximum floor area of the dwelling for compliance with the Building Regulations

Stainless Lite HP Slimline Model Selection Guide		
Dwelling type		Suggested model
Number of bedrooms	Number of bathrooms and shower rooms	
1-3	1 bathroom	HP180SL
2-3	1 bathroom + 1 shower room	HP180SL
2-3	1 bathroom + 2 shower rooms	HP180SL
2-4	2 bathrooms + 1 shower room	HP210SL

Model Selection

The suggested model sizes shown in the table opposite are based on a typical daily hot water usage and on the assumption that the heat pump will heat the domestic hot water to about 50°C. For higher specification, an increase of one model size should be considered.

When selecting a solar model, it is important to check the dedicated solar volume shown in table 1 is suitable for the total floor area of the dwelling and/or net area of the solar collectors to ensure compliance with the Building Regulations.

When sizing the hot water cylinder, please use MCS guidelines in MIS3005 and also refer to BS EN 806:1-5 AND BS EN 8558.

When Stainless Lite HP SOL is connected to both heat pump and solar thermal systems, then during the winter period the solar contribution will be negligible and the heat pump will only heat about 65% of the cylinder volume. This should be taken into account when selecting the model.

Please note that the two heat exchangers **must** be connected in parallel to the heat pump circuit when a solar thermal system is not installed, as shown in the schematic below.

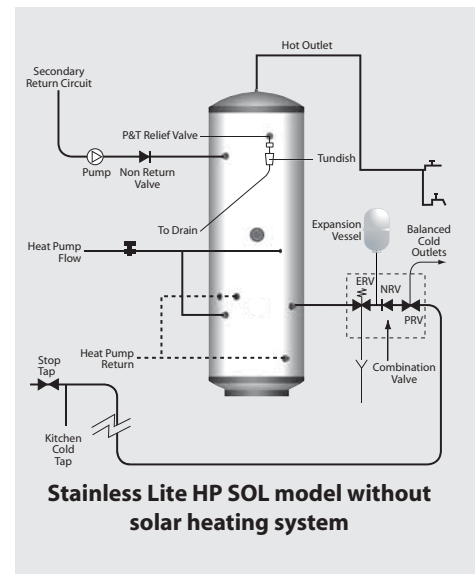

INSTALLATION

Stainless Lite HP/Heat Pump Selection Guide																
1 - Flow rates in various units for comparison with heat pump manufacturers data																
m ³ /h	0.50	0.75	1.00	1.25	1.50	1.75	2.00	2.25	2.50	2.75	3.00	3.25	3.50	3.75	4.00	4.25
l/min	8.33	12.50	16.67	20.83	25.00	29.17	33.33	37.50	41.67	45.83	50.00	54.17	58.33	62.50	66.67	70.83
l/sec or kg/s	0.14	0.21	0.28	0.35	0.42	0.49	0.56	0.63	0.69	0.76	0.83	0.90	0.97	1.04	1.11	1.18
2 - Velocity in pipe (limited to 1 m/s maximum) for pipe sizing																
m/s in 22mm	0.37	0.55	0.73	0.91	-	-	-	-	-	-	-	-	-	-	-	-
m/s in 28mm	0.23	0.34	0.45	0.56	0.68	0.79	0.90	-	-	-	-	-	-	-	-	-
m/s in 35mm	0.14	0.22	0.29	0.36	0.43	0.51	0.58	0.65	0.72	0.79	0.87	0.94	-	-	-	-
m/s in 42mm	0.10	0.15	0.20	0.25	0.30	0.35	0.40	0.45	0.50	0.55	0.60	0.65	0.70	0.75	0.80	0.85
3 - Operating power of heat exchanger suitable for cylinder based on a 5 degree temperature difference																
kW @ 5K dt	3-4	4-6	5.5-8	7-10	8-12	10-14	11-16	13-18	14-20	16-22	17-24	18-26	20-28	21-30	23-32	24-34
180HP							-	-	-	-	-	-	-	-	-	-
180HP + Sol											-	-	-	-	-	-
180HP Slim							-	-	-	-	-	-	-	-	-	-
210HP																
210HP + Sol												-	-	-	-	-
210HP Slim												-	-	-	-	-
250HP																
250HP + Sol												-	-	-	-	-
300HP																
300HP + Sol																-
400HP																
400HP + Sol																-
4 - Pressure loss (bar) for each flow rate above in the available coil combinations																
180HP	0.010	0.027	0.053	0.092	0.143	0.207	0.286	0.381	0.491	0.618	0.763	0.927	1.109	1.310	1.532	1.774
180HP + Sol	0.003	0.008	0.017	0.031	0.049	0.073	0.103	0.140	0.183	0.234	0.292	0.359	0.434	0.518	0.612	0.715
180HP Slim	0.004	0.010	0.018	0.030	0.044	0.062	0.083	0.108	0.136	0.167	0.202	0.241	0.283	0.329	0.379	0.432
210HP	0.017	0.040	0.074	0.118	0.173	0.239	0.316	0.405	0.505	0.617	0.741	0.877	1.025	1.184	1.356	1.540
210HP + Sol	0.013	0.033	0.064	0.107	0.164	0.234	0.318	0.417	0.532	0.663	0.810	0.975	1.156	1.356	1.574	1.810
210HP Slim	0.004	0.010	0.018	0.030	0.044	0.062	0.083	0.108	0.136	0.167	0.202	0.241	0.283	0.329	0.379	0.432
250HP	0.006	0.015	0.028	0.045	0.067	0.093	0.124	0.159	0.200	0.245	0.295	0.350	0.410	0.475	0.545	0.620
250HP + Sol	0.004	0.011	0.021	0.036	0.054	0.077	0.105	0.138	0.176	0.218	0.267	0.321	0.380	0.445	0.517	0.594
300HP	0.008	0.019	0.036	0.058	0.086	0.120	0.160	0.206	0.259	0.318	0.384	0.457	0.536	0.623	0.716	0.816
300HP + Sol	0.004	0.014	0.031	0.058	0.098	0.152	0.223	0.312	0.421	0.553	0.708	0.890	1.100	1.339	1.610	1.915
400HP	0.004	0.010	0.018	0.030	0.044	0.062	0.083	0.108	0.136	0.167	0.202	0.241	0.283	0.329	0.379	0.432
400HP + Sol	0.008	0.018	0.031	0.049	0.070	0.094	0.123	0.155	0.190	0.230	0.273	0.319	0.370	0.423	0.481	0.542

Stainless Lite HP/Heat Pump Selection Guide

The table above can be used to match heat pumps to heat pump cylinders.

To use, first obtain the maximum flow rate from the heat pump manufacturer's instructions, match this to the flow rates in section 1 and follow this flow rate's column down through the other sections.

Section 2 shows the velocity in the pipe work of different diameters at this flow rate. A maximum flow velocity of 1m/s has been chosen to limit flow noise. Use this section to choose the correct pipe diameter.

Section 3 shows the maximum operating power of the coils in the cylinder. Shaded squares show the range of operating powers suitable for a cylinder in either of its set ups.

Section 4 shows the pressure loss across the coils at this flow rate for all cylinders in both configurations.

INSTALLATION

General Restrictions

- The highest hot or cold water draw off point should not exceed 10 metres above the Pressure Reducing Valve.
- An ascending spray type bidet or any other appliance with a Class 1 back-syphonage risk requiring a type A air gap should not be used.
- Stainless Lite should not be used where steam is the primary heating medium, or in a situation where maintenance is likely to be neglected.
- Unvented cylinders are not suitable for use with solid fuel boilers.
- If the supply to the mixer fittings (other than a dual outlet type) is not taken from the balanced supply the system will become over pressurized and cause the pressure relief valve to discharge. Over time this could also cause the premature failure of the appliance itself which will not be covered by the warranty.**
- In larger properties with a number of bathrooms/en-suites and long pipe runs we would recommend that the balance cold supply is provided with its own pressure reducing valve and is not taken from the balanced cold connection on the combination valve. In this case it will also be necessary to fit a small expansion vessel on the balanced cold water system to accommodate the pressure rise caused by the increase in temperature of the balanced cold water.
- Check the performance requirements of the terminal fittings with regard to flow/pressure are suitable.

Shower Fittings

Aerated taps are recommended to prevent splashing. Any type of shower mixing valve can be used as long as both the hot and cold supplies are mains fed. However, all mains pressure systems are subject to dynamic changes particularly when other hot and cold taps/showers are opened and closed, which will cause changes in the water temperature at mixed water outlets such as showers. For this reason and because these are now no more expensive than a manual shower we strongly recommend the use of thermostatic showers with this appliance. These must be used in 3 storey properties where the impact on pressure/temperature of opening another tap in the system is greater than normal. The shower head provided must also be suitable for mains pressure supplies.

Pipe Layout

In all mains pressure installations it is important to remember that the incoming cold supply must be shared between all terminal fittings. It is important that a 22mm supply is brought to the appliance and a 22mm take-off is continued at least to the bath. If there are two baths, 28mm pipework should be considered. One metre of smaller diameter pipework, or flow restrictors, should be provided on the final connection to all outlets so as to balance the water available. In any event the distribution pipework should generally be in accordance with BS EN 806-1 to 5.

Plastic Pipework

This appliance is suitable for use with plastic pipework as long as the material is recommended for the purpose by the manufacturer and is installed fully in accordance with their recommendations.

Secondary Hot Water Circulation

Some models are fitted with a secondary return tapping as standard (see table 1 for details). If fitted, an extra expansion vessel may be necessary. A non-return valve MUST be FITTED near the return connection. No valve or terminal fitting should be installed between the non return valve and the cylinder. (See schematic arrangement on page 13.) All pipes kept hot by the secondary circulation should be insulated.

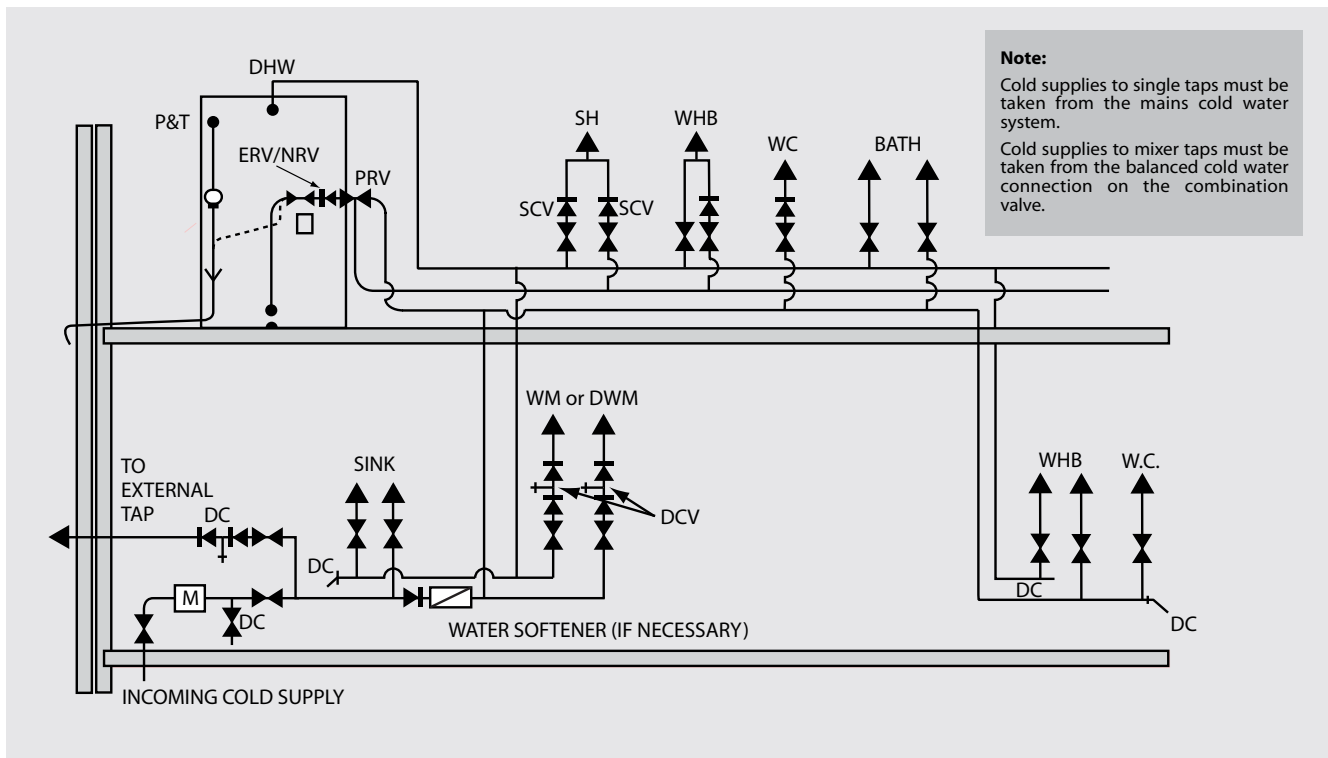

INSTALLATION

Typical Discharge Pipe Arrangement

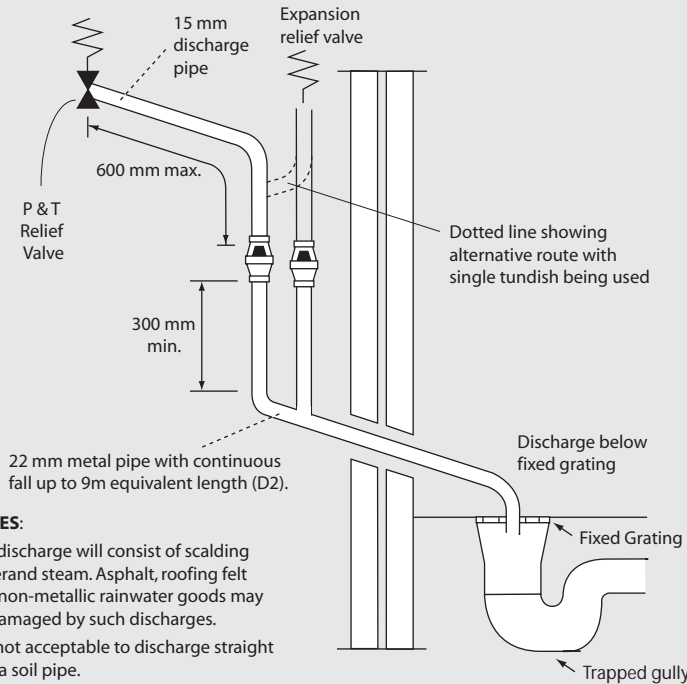

Pressure & Temperature/expansion Relief Valve Pipework

The relief valve should be installed to discharge in accordance with G3 of the Approved Document of the Building Regulations and should be piped to where it is visible, but will not cause danger to persons or damage to materials.

The following information is taken from Approved Document G3 of the Building Regulations and is provided to assist with the design and installation of the discharge pipework. However, the information is not exhaustive and reference should always be made to Approved Document G3 of the Building Regulations. The final decision regarding any arrangements rests with Building Control and it is recommended that their advice is sought if you have any concerns regarding this aspect of the installation.

The two safety valves will only discharge water under fault conditions. When operating normally water will not be discharged.

The tundish should be vertical, located in the same space as the unvented hot water storage system and be fitted as close as possible and within 600mm of the safety device e.g. the temperature relief valve.

The discharge pipe (D2) from the tundish should terminate in a safe place where there is no risk to persons in the vicinity of the discharge, be of metal and:

- a) Be at least one pipe size larger than the nominal outlet size of the safety device unless its total equivalent hydraulic resistance exceeds that of a straight pipe 9m long i.e. discharge pipes between 9m and 18m equivalent resistance length should be at least two sizes larger than the nominal outlet size of the safety device, between 18 and 27m at least 3 sizes larger, and so on. Bends must be taken into account in calculating the flow resistance. Refer to the table and the worked example.

An alternative approach for sizing discharge pipes would be to follow BS EN 806-2:2005 Specification for design installation, testing and maintenance of services supplying water for domestic use within buildings and their curtilages.

- b) Have a vertical section of pipe at least 300mm long, below the tundish before any elbows or bends in the pipe work.

- c) Be installed with a continuous fall.

Worked Example

The example below is for G1/2 temperature relief valve with a discharge pipe (D2) having 4 elbows and length of 7m from the tundish to the point of discharge.

From Table 1:

Maximum resistance allowed for a straight length of 22mm copper discharge pipe (D2) from a G1/2 temperature relief valve is: 9m subtract the resistance for 4 x 22mm elbows at 0.8m each = 3.2m.

Therefore the maximum permitted length equates to: 5.8m.

5.8m is less than the actual length of 7m therefore calculate the next largest size.

Maximum resistance allowed for a straight length of 28mm pipe (D2) from a G1/2 temperature relief valve equates to: 14m.

As the actual length is 7m, a 28mm (D2) copper pipe will be satisfactory.

Table 1: Sizing of copper discharge pipe 'D2' for a temperature relief valve with a G1/2 outlet size (as supplied)

Size of discharge pipework	Maximum length of straight pipe (no bends or elbows)	Deduct the figure below from the maximum length for each bend or elbow in the discharge pipe
22mm	Up to 9m	0.8m
28mm	Up to 18m	1m
35mm	Up to 27m	1.4m

INSTALLATION

d) It is preferable for the discharge to be visible at both the tundish and the final point of discharge but where this is not possible or practically difficult there should be clear visibility at one or other of these locations. Examples of acceptable discharge arrangements are:

1. Ideally below the fixed grating and above the water seal in a trapped gully.
2. Downward discharges at a low level; i.e. up to 100mm above external surfaces such as car parks, hard standings, grassed areas etc are acceptable providing that where children play or otherwise come into contact with discharges, a wire cage or similar guard is positioned to prevent contact whilst maintaining visibility.
3. Discharges at a high level; e.g. into metal hopper and metal down pipe with the end of the discharge pipe clearly visible (tundish visible or not) or onto a roof capable of withstanding high temperature discharges of water and 3m from any plastic guttering systems that would collect such discharges.
4. Where a single pipe serves a number of discharges, such as in blocks of flats, the number served should be limited to not more than 6 systems so that any installation can be traced reasonably easily. The single common discharge pipe should be at least one pipe size larger than the largest individual discharge pipe to be connected. If unvented hot water storage systems are installed where discharges form safety devices may not be apparent i.e. in dwellings occupied by blind, infirm or disabled people, consideration should be given to the installation of an electronically operated device to warn when discharge takes place.

Safety

The safety devices supplied or fitted on an Stainless Lite are selected for their suitability for the temperatures and pressures involved. They must not be changed, removed or by-passed and it is essential that only genuine replacement parts supplied or approved by Gledhill Building Products Limited are used. This includes the immersion heaters, which must incorporate an energy cut-out. All parts are available to approved installers from Gledhill Building Products Limited, Sycamore Estate, Squires Gate, Blackpool (Telephone 01253 474402).

Combination Inlet Group

Combines elements 1, 2 and 3 below.

1. *Pressure Reducing Valve* - This must be fixed near the cylinder. The cold water supply to any mixer taps/showers must be taken from the cold water tapping of this valve to ensure balanced hot and cold pressures. This valve is factory set to ensure the correct operating pressure for the Stainless Lite.
2. *Non Return Valve* - This is integral with the pressure reducing valve to prevent backflow of hot water towards cold water draw off points.
3. *Cold Water Expansion Relief Valve* - This safety device is preset at the factory and will relieve excess cold water pressure resulting from a fault condition.

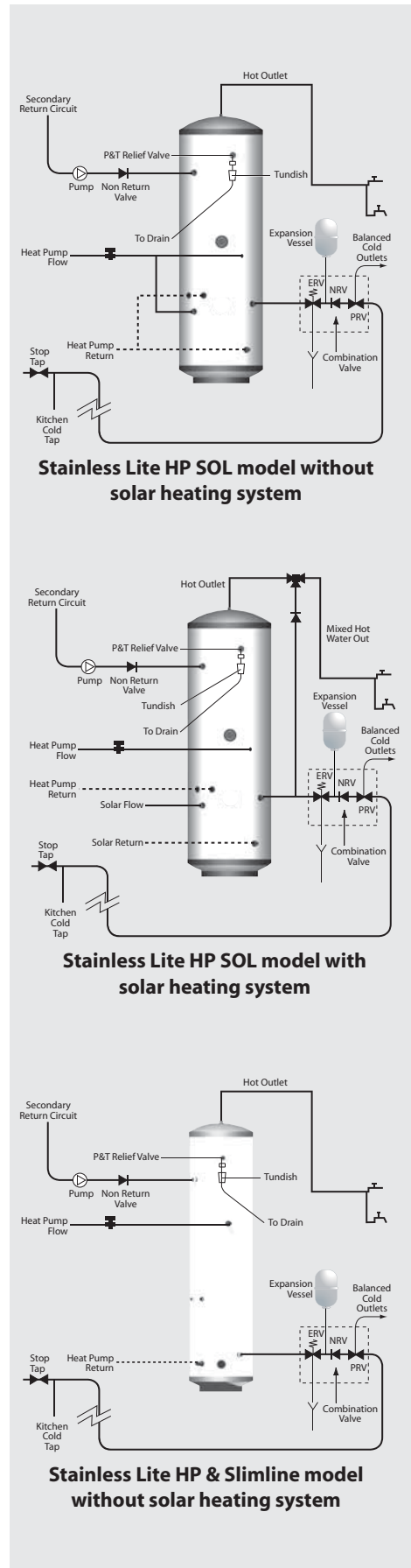

INSTALLATION

Lift up temperature/pressure relief valve

This safety device is also pre-set at the factory and relieves before the temperature reaches 100°C. It is also a Pressure Relief Valve, and is pre-set to 6 bar.

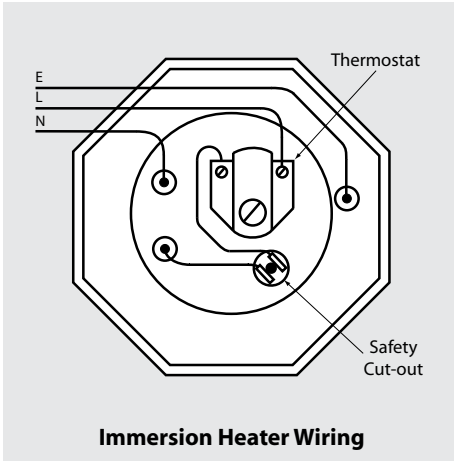

Immersion Heater

All stainless Lite HP models are fitted with a 3kW immersion heater so that the store temperature can be raised above that which the heat pump provides, to boost the hot water performance if necessary and to protect against legionella eg. once a day or once a week.

These are 3kW 240V AC heaters and incorporate a thermostat and a manually reset energy cut-out which operates at 85°C. They have incolloy elements to prolong their life expectancy in aggressive water conditions.

External wiring to the immersion heaters must be in accordance with the relevant IEE Wiring Regulations and the circuit must be protected by a suitable fuse and a double pole isolating switch.

The correct method of terminating the wiring to the immersion heater is shown above.

Usage of the product in non-domestic commercial applications can be extremely intensive and stressful to various components. We recommend that titanium immersion heaters are fitted in such situations, rather than the incoloy heater supplied as standard. Titanium immersion heaters offer superior strength, weight and a smoother finish which enable them to better withstand the extreme stress and temperature fluctuation often encountered within non-domestic environments and situations where water quality is poor – ensuring improved performance and extended operational life. This can be purchased as an extra from your Gledhill depot under code number SH002.

The operation of the boost immersion heater can also be controlled by means of an independent time switch as shown schematically below. The 'ON' time settings on the immersion heater should be between 30 - 60 minutes later than the 'ON' times set for the hot water programmer channel.

For example if the hot water is programmed to come on between 0600 - 0900 and 1700 - 2200 then the immersion heater setting should be 0640 - 0900 and 1740 - 2200. This will give hot water heating by heat pump a priority.

Line Strainer

This is integral within the combination inlet group to reduce the likelihood of contaminants fouling the valve seat. Following installation this line strainer must be cleaned and replaced. This needs to be carried out on a regular basis, as part of the annual maintenance/service check.

Tundish

This is to allow the discharge from any Relief Valve to be seen. It must be fitted away from any electrical devices. See page 13 for discharge pipework details.

Safety

The immersion heaters must be earthed and they must be isolated from the mains before the cover is removed on every occasion. Replacement immersion heaters should be obtained from Gledhill Building Products Limited.

Control/overheat Dual Thermostats

Care must be taken to ensure that the solar probes are fully inserted into the pockets provided.

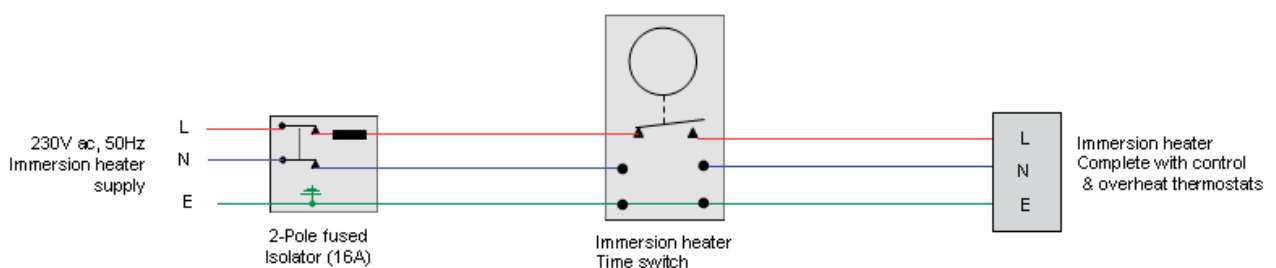

Typical schematic wiring diagram for the boost immersion heater using immersion programmable immersion heater timer.

INSTALLATION

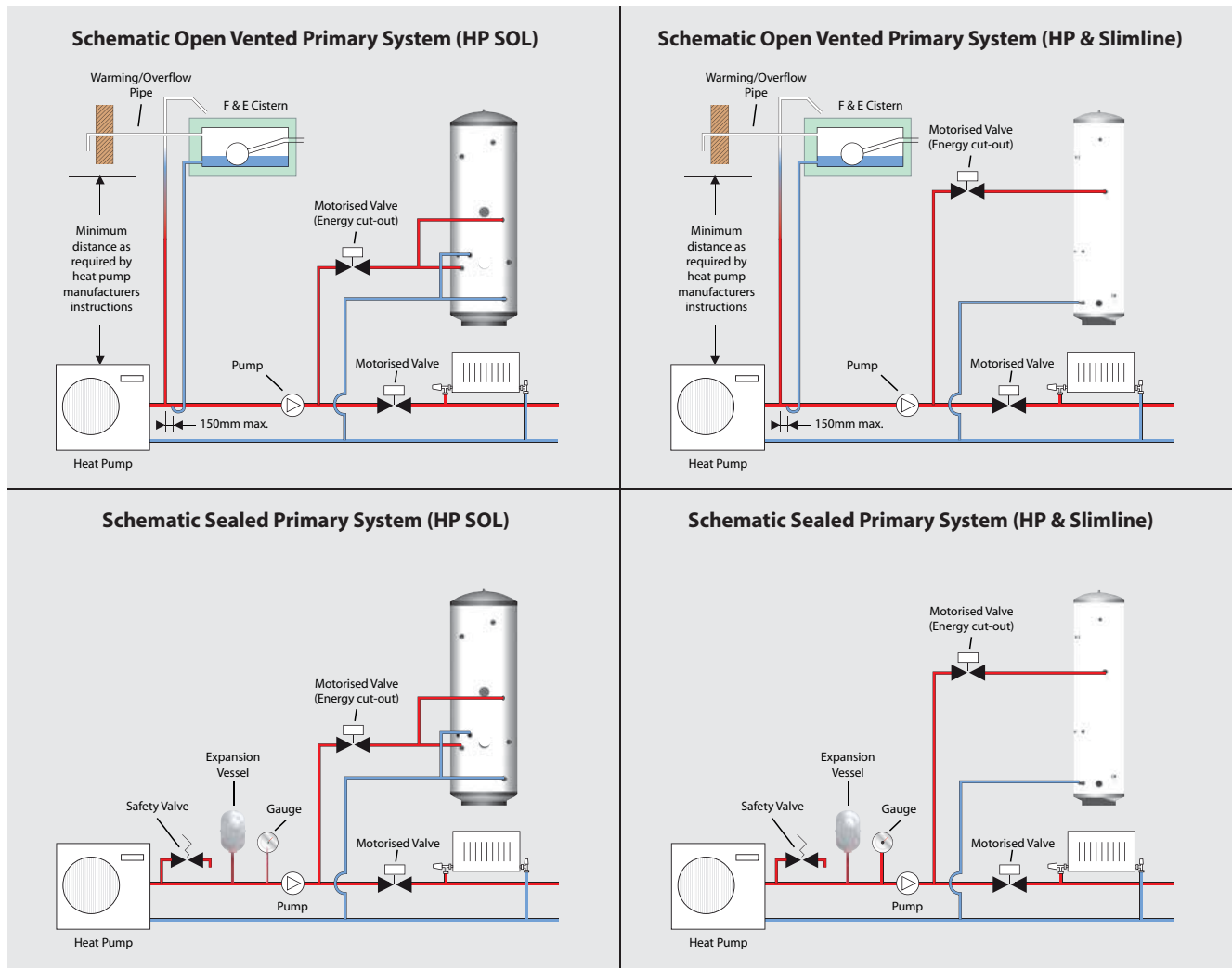

Heating And Primary Systems

Although the heat pump and the primary heating system should be sized and installed in accordance with BS EN 12828:2003, BS EN 12831:2003 & BS EN 14336:2004 the following should also be taken into account during the design and installation phase.

The heat pumps normally operate at lower flow temperatures; typically 45 – 55°C compared with 75 – 80°C for the boilers. Therefore if traditional radiators are used then, these should be oversized in accordance with the heat pump manufacturers recommendations.

For optimum efficiency (i.e. COP of a heat pump), low temperature under floor heating system should be considered.

The heat pumps normally operate at lower temperature difference between flow and return compared with the traditional boilers and therefore when sizing the pipework heat pump manufacturers recommendations should be taken into account.

Safety

Stainless Lite HP is fitted with a combined temperature and pressure relief valve to cope with any increase in temperature and pressure in the cylinder above the design limits, when used with heat sources up to 45kW total output. This is the maximum heat input to the cylinder allowed by section G3 of the 'Approved Document G' of the Building Regulations.

The heat supply to the cylinder and hence the temperature of the stored water should be controlled as outlined below: -

- Heat supply from the primary heat source i.e. heat

The 2-port spring return motorised valve supplied should be fitted adjacent to the unit and controlled by the cylinder thermostat (combined control and overheat thermostat) supplied with the unit. The motorised valve and the thermostat must be wired so that the control thermostat contact breaks when the set temperature is reached or the overheat thermostat contacts break when an overheat condition develops. The operation of the heat source should be controlled via the auxiliary switch of the motorised valve.

It is important to follow the wiring diagrams in the wiring section of these instructions.

INSTALLATION

- Sealed heating system

A heat pump selected must be suitable for use in a sealed heating system which may have working pressure of up to 3.0bar and it must be fitted with an overheat temperature cut-out device.

Unvented (i.e. sealed primary circuits may be filled or replenished by means of a temporary connection between the circuit and a water supply pipe provided a WRC 'Listed' double check valve and filling loop or some other no less effective backflow prevention device is permanently connected at the inlet to the circuit and the temporary connection is removed after use.

Alternatively, a CA device can be used which will allow the system to be permanently connected to the cold mains supply. The primary system can then be topped up,

when required, in the same way as an open vented system fitted with an F&E cistern.

- Open vented heating system

It is essential that the primary circuit between the boiler and the Stainless Lite is pumped and that the cold feed and open vent connections are positioned to prevent pump over into the feed and expansion cistern and to ensure that the open vent is correctly sized. A typical arrangement of the open vented system is shown in diagram opposite.

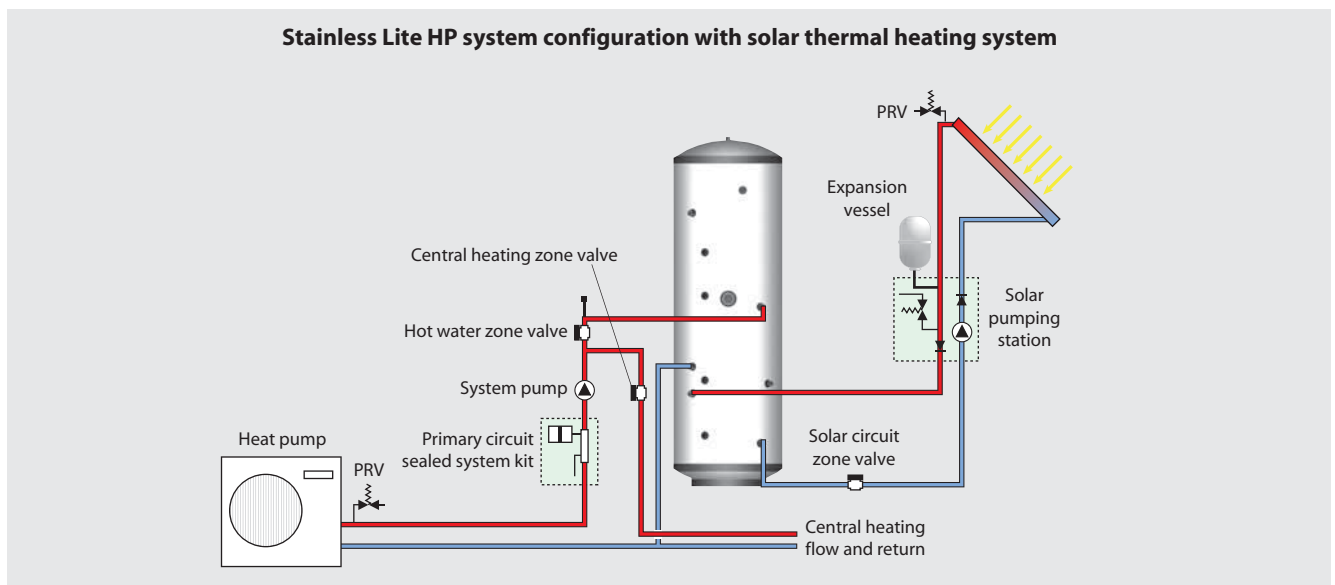

Solar Heating System

Stainless Lite HP SOL is suitable for use with combined heat pump and solar thermal heating systems. All components in a solar primary circuit must be marked or identified in such a way that their design pressure and temperature can be readily determined

A safety device (pressure relief valve) to control the risk of over-pressure in system components should be fitted. A termination from a safety pressure device should minimise the risk of damage to persons or materials. Suitable locations are a high temperature receptacle, an internal gully or else issue externally at ground level. High level termination from walls or on roofs could cause injury to people or animals below if the valve were to release scalding water and steam.

The pipe leading to the safety device and the collector should be of rigid and non-deformable construction, without any possibility of restriction or disclosure by any other fitted component. A more detailed diagram of our recommended arrangement for a typical solar system is shown on page 15.

This provides all the necessary controls and safety devices necessary for the solar system i.e. the two port zone valve is wired as an energy cut out and the pump/valve will only allow heat transfer as required under control of the solar controller.

The pocket provided for the Dual Thermostat also includes the facility to accommodate an 8mm diameter sensor which, with the sensor located in the solar collector (or in the flow pipe immediately adjacent to the collector), will provide the information required by the solar controller.

Note: If the motorised valve is not used then any factory built hydraulic station for solar use MUST be fitted with suitable non-return valves in both flow and return pipes to prevent gravity circulation when the pump is not running.

If there is a possibility of the solar controller that you install causing the cylinder temperature to exceed 80°C, under normal working conditions, then a Solar tempering valve must be fitted to the domestic hot water outlet of the cylinder. This must limit the hot water temperature to a maximum of 60°C.(ref building regulations part G3 3.63). This product can be supplied from Gledhill part number XC007 which has a inlet temperature limit of 100°C. Suitable plumbing configurations for installing this valve are shown on page 12 of this manual. NB. Overheat thermostats may require resetting if the solar thermal heat source raises the cylinder temperature above 85°C.

INSTALLATION

Schematic Showing Solar Wiring Requirements

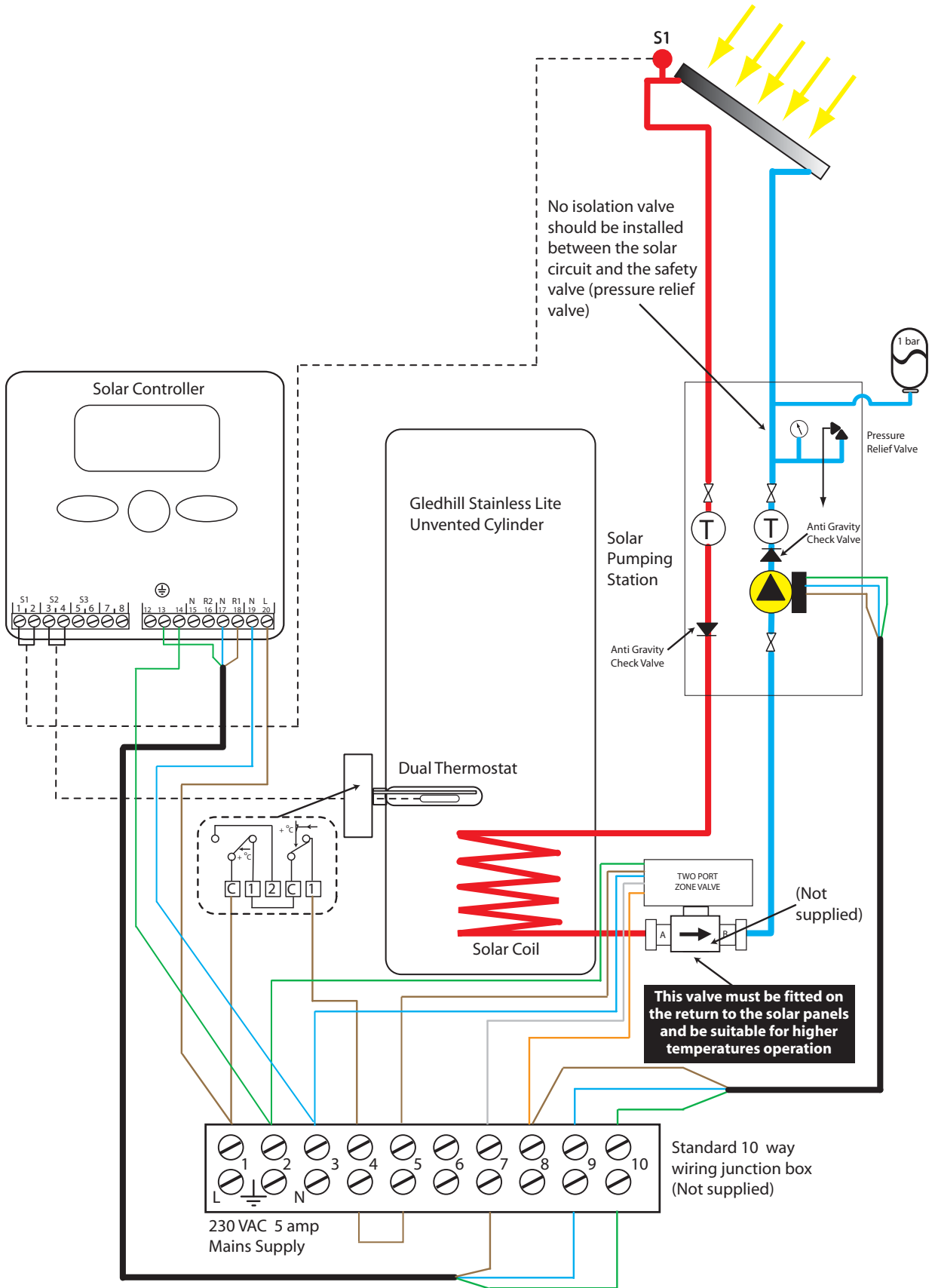

INSTALLATION

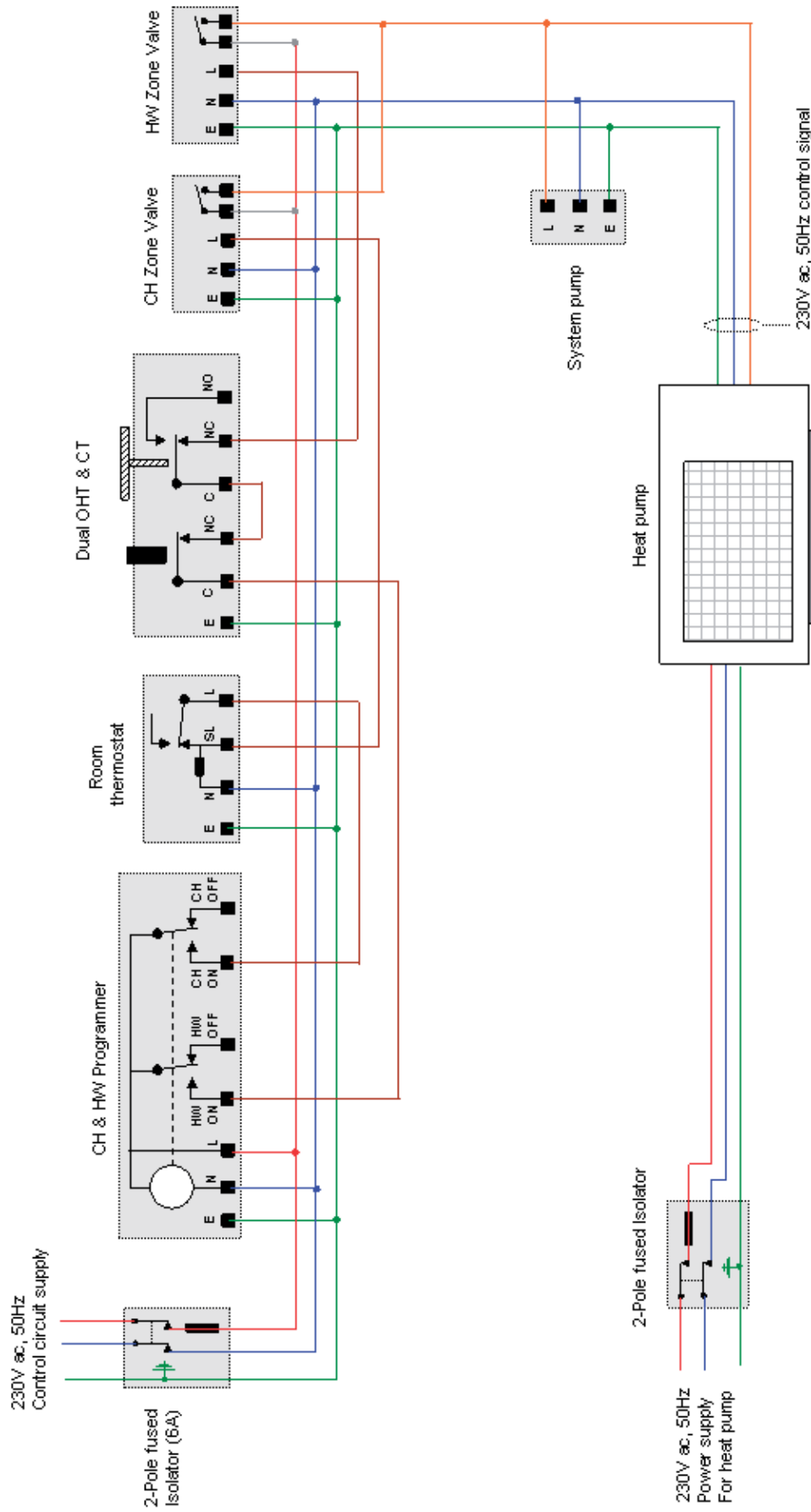

Typical schematic wiring diagram for Stainless Lite HP heating system.
Please refer to the heat pump manufacturers installation instructions.

INSTALLATION

Connections can come loose in transit, and all should be checked before installation.

Ensure that the immersion heater achieves a temperature of at least 60°C in the store and that the wiring is in accordance with the diagram.

Check the pressure on the air side of the expansion vessel = 3 bar. This must be done when the water in the cylinder is free to expand in atmospheric pressure or the cylinder and relevant pipe work is empty.

Check that the drain cock is closed, and open all the cold and hot water taps and other terminal fittings. Allow the system to fill with water, and to run until there is no air left in the system. Close the taps and inspect the system closely for leaks.

Manually open the Relief Valves one by one and check that water is discharged and run freely through the tundish and out at the discharge point. The pipework should accept full bore discharge without overflowing at the tundish, and the valve should seat satisfactorily.

In line with good plumbing practice, use with excessive flux should be avoided.

When soldering above the cylinder, ensure flux/solder does not contaminate the cylinder below, since this can cause corrosion, Flushing should be done performed as per BS EN 806:4 2010 section 6.2

Allow the cylinder to heat to normal working temperature, then thoroughly flush the domestic hot and cold water pipework through each tap.

NOTE: If this appliance is to be installed in other than a single domestic dwelling ie. in an apartment block or student flats etc., the hot and cold water system will need to be disinfected in accordance with BS EN 806:4 2010 section 6.3 and the Water Regulations.

Because the Stainless Lite appliance is stainless steel, the use of chlorine as the disinfection agent can cause damage unless the appliance is adequately flushed and refilled with the mains water immediately on completion of the disinfection procedure. Damage caused through a failure to do this adequately will not be covered by the warranty.

For the above reasons we recommend the use of a non chlorine based disinfectant such as Fernox LP Sterox as manufactured by Cookson Electronics when carrying out disinfection of systems incorporating these appliances.

IS DRAINED PRIOR TO CHECKING OR REMOVING FILTER FROM THE COMBINATION INLET GROUP.

Allow the cylinder to heat to normal working temperature with whatever heat source is to be used, and check again for leaks. The Pressure Relief Valve should not operate during the heating cycle.

The boiler/heating systems should be filled and commissioned in accordance with good practice following the guidance in BS 7593:2006/the boiler manufacturers instructions. This includes adequately flushing the system to remove any debris that may have been introduced during installation/maintenance.

NOTE

At the time of commissioning, complete all relevant sections of the Benchmark Checklist located on the inside back pages of this document.

This must be completed during commissioning and left with the product to meet the Warranty conditions offered by Gledhill.

IMPORTANT - DRAIN DOWN PROCEDURE

- 1 Switch off both the heat pump and the immersion heater
- 2 Open the nearest hot tap and run all hot water until cold
- 3 Close the incoming cold main at the stop tap
- 4 **Hold open the pressure and temperature relief valve until water stops discharging into the tundish**
- 5 Open all the taps in the property
- 6 Open the drain cock and immediately hold open the pressure and temperature relief valve again until the cylinder is empty

Remove the filter from the combination inlet group clean and replace. Refill the system and open all hot taps until there is no air in the pipe work. **ENSURE CYLINDER**

USER INSTRUCTIONS

Your Stainless Lite unvented cylinder is automatic in normal use, but requires routine maintenance which is normally carried out at least annually along with the boiler service. The maintenance must be carried out by a suitably competent tradesperson who is qualified to work on unvented cylinders. The checks/work needed are listed in the maintenance part of these Instructions.

The heat pump control thermostat should switch to the hot water zone valve before the heat pump starts to cycle on its internal thermostats. For example if the maximum primary flow temperature available from the heat pump is 55°C, then the control thermostat should be set to 48°C. (This setting should not be changed by the occupant.)

When initially opening the taps, a small surge in flow may be experienced, which disappears as the pressure in the system stabilises. This is quite normal with these types of systems and does not indicate a fault.

In some areas the water will initially appear cloudy, but will quickly clear when left to stand. This is nothing to be concerned about and is due to aeration of the water.

WARNING - If water is seen flowing through the tundish, this indicates a fault condition which needs action.

If the discharge is hot and continuous, turn the boiler and/or the immersion heaters off, but do not turn off the cold water to the appliance until the discharge is cold.

Note: The discharge may stop by itself as the discharge cools.

If the discharge is cold and intermittent, no immediate action is needed but this indicates a problem with the expansion vessel.

However, in both cases you must call the registered installer / a suitably qualified, competent tradesperson, advise them that you have an unvented cylinder and request a maintenance visit.

DO NOT, at any time, tamper in any way with the safety valves or overheat thermostats/wiring.

SERVICING AND MAINTENANCE

The Registered Installer is responsible for the safe installation and operation of the system. The installer must also make his customer aware that periodic maintenance of the equipment is essential for safety.

Maintenance periods will vary for many reasons. Gledhill Building Products Ltd recommend a maximum of 12 months to coincide with boiler maintenance. Experience of local water conditions may indicate that more frequent maintenance is desirable, eg, when water is particularly hard, scale-forming or where the water supply contains a high proportion of solids, eg, sand. Maintenance must include the following:

1. Check and clean filter
2. Manually check the operation of the temperature relief valve.
3. Manually check the operation of the expansion relief valve.
4. Check discharge pipes from temperature and expansion relief valves are free from obstruction and blockage and are not passing any water.
5. Check the condition and if necessary descale the heat exchangers in hard water areas.
6. Check that water pressure downstream of pressure reducing valve is within the manufacturers limits.
7. Check operation of motorised valve.
8. Check the pressure on the air side of the expansion vessel. This must be done when the volume in the cylinders is cold.
9. Check and advise the householder not to place any clothing or other combustible materials against or on top of this appliance.
10. On completion of the work, fill in the Benchmark Service Record at towards the back of this manual.

IMPORTANT NOTE

When draining down the appliance for any reason, the instructions provided in the Commissioning Section MUST be followed to prevent potential damage to the cylinder.

After servicing, complete the relevant Service Interval Record section of the Benchmark Checklist located on the inside back pages of this document.

SERVICING AND MAINTENANCE

Scale

In hard water areas it is recommended that an in-line scale inhibitor is fitted. Reducing the temperature of the stored water will reduce the rate at which scale forms. If the recovery rate is badly affected, this is an indication that scaling may have occurred. In this event, follow the procedures as recommended by a reputable Water Treatment Company.

General

No water at the tap. Check that the mains water supply is turned ON. Check the line strainer is not blocked. Check that the combination valve has been fitted so that water is flowing in the correct direction.

If the water at the tap is cold, ensure that the boiler has been switched ON and is working correctly. Check that there are no air locks in the primary system. ISOLATE THE UNIT AT THE MAINS ELECTRIC SUPPLY AND THEN CHECK THE FOLLOWING:

- i. The cylinder thermostat
- ii. The thermal cut-out, which can be re-set by pushing the red button
- iii. The motorised valve
- iv. The boiler thermostat
- v. The boiler thermostat cut-out (if fitted)

ANY ENERGY CUT-OUT MUST NEVER BE BY-PASSED UNDER ANY CIRCUMSTANCES.

If the units are not getting hot and the heat source is electrical, ensure that the immersion heaters are isolated from the mains before re-setting the energy cut-out. If the immersion heater(s) need replacing this should be done with the units supplied from Gledhill Building Products Limited. Same day despatch to approved installers can be arranged by telephoning 01253 474402.

Discharge From Relief Valves

If cold water is discharging from the expansion relief valve into the tundish check the pressure on the expansion vessel when cold and recharge if necessary.

If the fault continues and the problem cannot be stopped by operating the easing control a few times then either the Pressure Reducing Valve or the Relief Valve may be at fault. If the cold water pressure is too high, this would suggest that the Pressure Reducing Valve is at fault and the Gledhill approved replacement should be fitted. If the pressure is correct then the Relief Valve will require replacing with a Gledhill approved component.

See Commissioning for drain down procedure.

If there is an overheat fault and very hot water is being discharged, turn off the heat source, **but not the water supply**.

When the supply is cool, check thermostats and energy cut-outs in the boiler and immersion heaters and replace the faulty component with a unit supplied by Gledhill and check that it works correctly before returning the system to full operation.

SERVICING AND MAINTENANCE

FAULT - No Hot Water

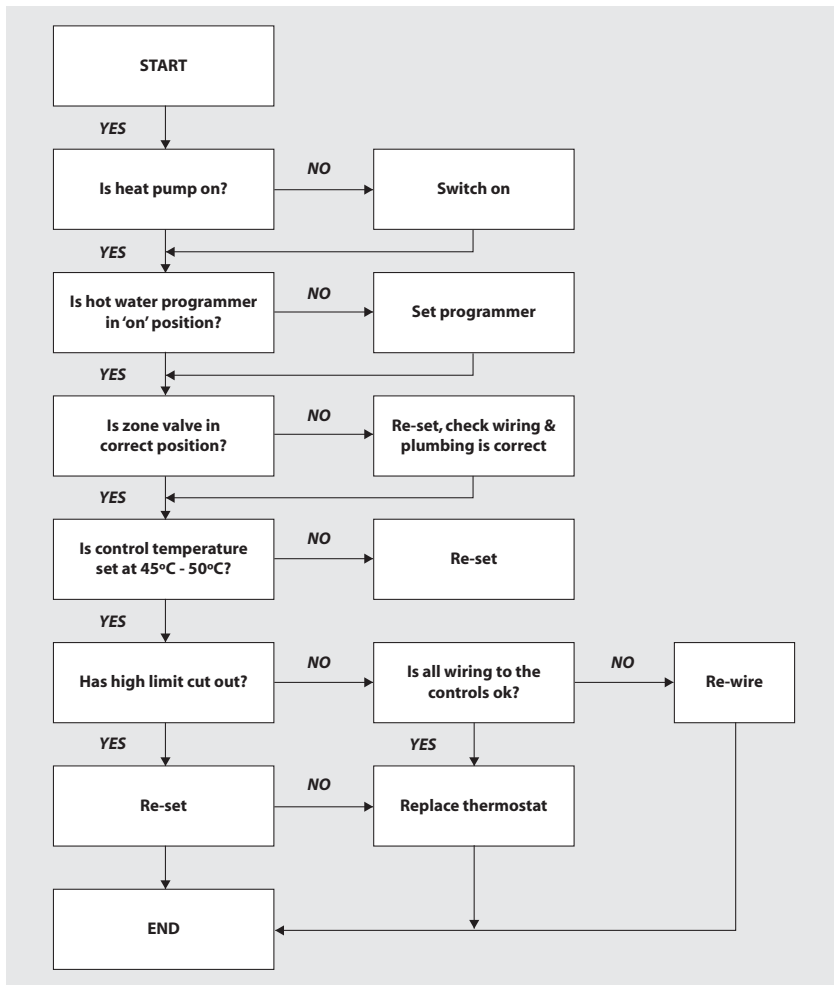

FAULT - Poor Water Flow at Hot Taps

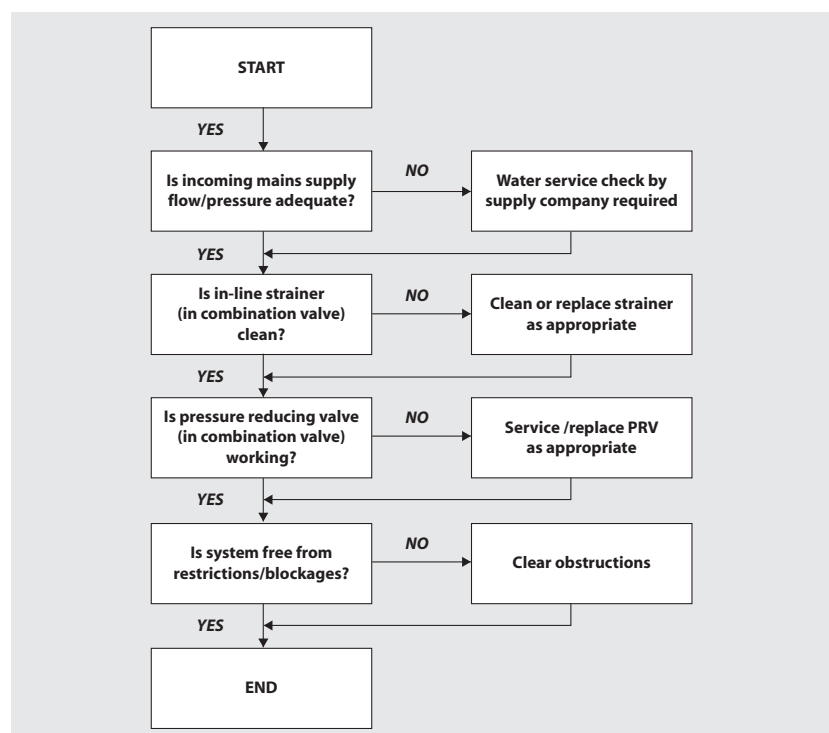

SERVICING AND MAINTENANCE

FAULT - Water Discharge Into Tundish

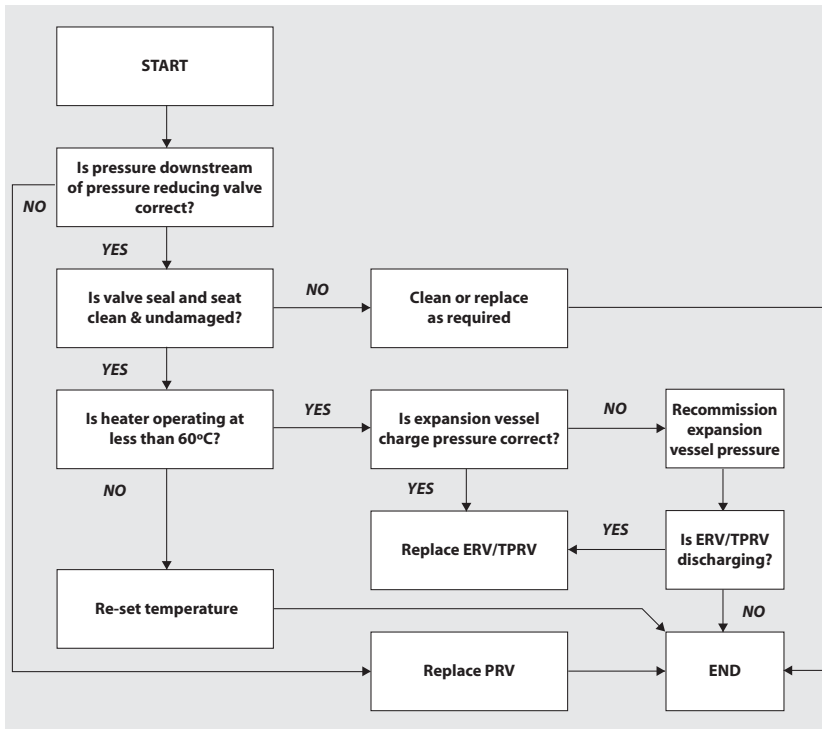

SPARE PARTS LIST			
	Description	Quantity	Stock Code No.
1	3kW immersion element	1	SH001
2	22mm 90° compression elbow c/w/drain	1	SF003
3	Lift up pressure and temperature relief valve 6 bar 92-95°C	1	SG017
4	Inlet group set at 3 bar c/w expansion relief valve set at 4.75 bar	1	SG010
5	¾" flexible hose	1	SG003
6	18 litre expansion vessel	1	XG191
7	24 litre expansion vessel	1	XG192
8	Wall mounting bracket for 18/24 litre expansion vessel	1	XG184
9	35 litre expansion vessel	1	XG193
10	Wall mounting bracket for 35 litre expansion vessel	1	XG058
11	22mm 2 port valve (indirects only)	1	XG083
12	Junction wiring box (12 way)	1	XG129
13	Control and overheat limit thermostat	1	XG168
14	15mm x 22mm tundish	1	XG173
15	28mm 2 port valve	1	XC012

APPENDIX

Water Savings

Water Related Costs Can Be Reduced By Good Plumbing Practice

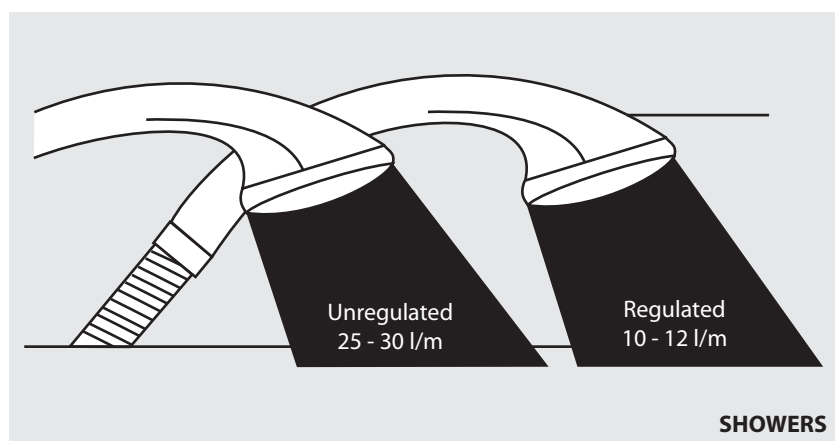
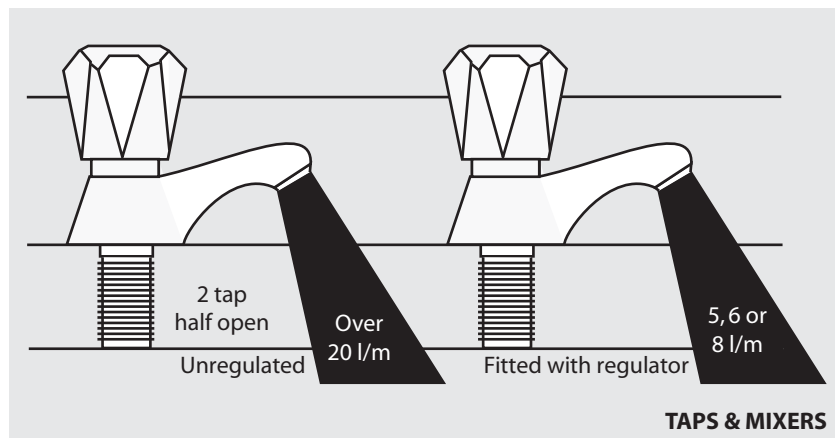

Vast quantities of water are needlessly run off to waste due to Taps, Mixers and Showers discharging flow rates far in excess of the rates required for them to perform their duties.

The contrasting flow rates shown on this leaflet clearly illustrate the savings that can be made whilst still providing a good performance.

British made Aquaflow Regulators provide constant flow rates by automatically compensating for supply pressure changes between 1 bar & 10 bars.

To facilitate installation into the wide range of plumbing equipment which is encountered in the U.K, Four Fixing Options are available:-

Options For Showers

1. MXF "DW" Range - For fitting behind Fixed Shower Heads or onto Flexible Hoses for Handshowers (preferably onto the inlet end when lightweight hoses are used).
2. Compression Fitting Range. "In Line" regulators as in Option 4 for Taps & Mixers.

Information by courtesy of

AQUAFLOW REGULATORS LTD

Haywood House, 40 New Road, Stourbridge, West Midlands DY8 1PA
TELEPHONE (01384) 442611 FAX: (01384) 442612

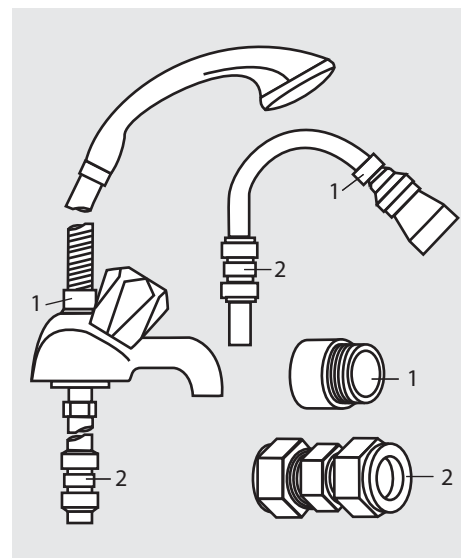

4 Fixing Options For Taps & Mixers

1. MK Range - Combined Regulators & Aerator for screwing onto Taps & Mixers with internal or external threads on their noses. AntiVandal models also available.
2. MR05-T Range - Internal Regulators. Push-fit into Tap or Mixer seats. Produced in three sizes - 12.5mm (BS1010), 12mm & 10mm, Flangeless models also available for Taps with Low Lift washers.
3. MXF Standard Range - Screw on tail models for Taps & Mixers. Fix onto the tails before fitting the tap connectors. Available in 3/8", 1/2", 3/4" and 1" BSP.
4. Compression Fitting Range - "In Line" regulators housed in 15mm & 22mm CXC Couplers & Isolating Valves. "UKWFB" listed by the Water Research Centre. Isolation valves available for slotted screwdriver operation or with coloured plastic handles. Now available also in plastic bodied push-fit couplers & valves.

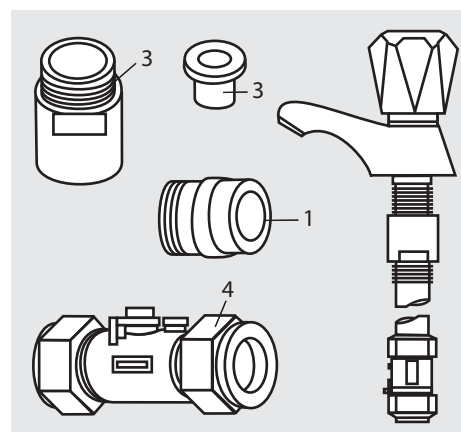

APPENDIX

MANUAL HANDLING OF APPLIANCE PRODUCTS

Description

Manual handling means any transporting or supporting of a load (including lifting, putting down, pushing, pulling, carrying or moving) by hand or bodily force.

Scope

This assessment will cover the largest unit within each product range manufactured by Gledhill.

For specific weights and dimensions please refer to technical data section.

Main Hazards

Vision may not be clear due to the size of the products. Adopting an incorrect method of lifting may cause injury, attempting to lift these products will require help from others. (Team lifts)

Control Measures

Manual lifting procedure

The lift, key factors in safe lifting are:

- a. **Balance**
 - b. **Position of back**
 - c. **Positioning of the arms and body**
 - d. **The hold**
 - e. **Taking the lead for team lifts**
-
- a. **Balance** - Since balance depends essentially upon the position of the feet, they should be apart about hip breadth with one foot advanced giving full balance sideways and forward without tension. In taking up this position, lifting is done by bending at the knees instead of the hips and the muscles that are brought into use are those of the thigh and not the back.
 - b. **Position of back** - Straight - not necessary vertical. The spine must be kept rigid, this coupled with a bent knee position, allows the centre line of gravity of the body to be over the weight so reducing strain.
 - c. **Positioning of arms and body** - The further arms are away from the side, the greater the strain on the shoulders, chest and back. Keep elbows close to the body arms should be straight.
 - d. **The hold** - Before lifting ensure you have a good hold.

- e. **Taking the lead for team lifts**- As more than one person is required for these products ensure that one person is taking the lead. **This may be you** so ensure that each person that is helping is made aware of the weight and of the items listed within this assessment. Make sure you and any others helping know the route you intend to take that it is clear of any obstructions. Never jerk the load as this will add a little extra force and can cause severe strain to the arms, back and shoulders. If there are steps involved decide on where you will stop and take a rest period. Move smoothly and in unison taking care to look and listen to others helping with the lift. Where possible use a sack truck to move the product over long flat distances, only lift the products when necessary. If in doubt stop and get more help.

Individual capability

Individual capability plays an important part in handling these products. Persons above average build and strength will find it easier and should be in good health. Persons below average build and strength may require more rest periods during the handling process.

Pregnant women should not carry out this operation.

Persons who are not in good health should seek medical advice prior to commencing any lifting or manual handling operation.

Residual risk

Following the guidelines given above will reduce any risk to injury.

All persons carrying out this operation must be fully trained and copies of the specific risk assessment made available for inspection and use in their training process.

Further guidance on Manual Handling can be obtained from the Health and Safety Executive. Manual Handling Operations Regulations 1992.

NOTES

NOTES

Gledhill (Building Products) Ltd

AMD.DECEMBER 2013

CONDITIONS OF SALE & GUARANTEE TERMS

1. Gledhill (Building Products) Ltd ("We" or "Gledhills") only do business upon the Conditions which appear below and no other. Unless we so agree in writing these Conditions shall apply in full to any supply of goods by us to the exclusion of any Conditions or terms sought to be imposed by any purchaser. These Conditions of Sale and Warranty Terms override those which are contained on the Invoice Forms and all Sales are now subject to these Conditions of Sale and Warranty terms only.

2. PRICE

Once an order or call off has been accepted the price will be held for three months **but if delivery is extended beyond that period at the customer's request, then we reserve the right to amend the price when necessary.** The company reviews its pricing annually to adjust for changes in our cost base. We reserve the right to alter prices at any time for severe movements in raw materials (mainly copper and steel). If there is to be a change we will give customers at least **four weeks** notice but **anything delivered** after that date will be at the revised price. An order may not be cancelled or varied after acceptance without the written consent of the company. Such cancellation or variation shall be subject to such reasonable charges as may be appropriate.

3. SPECIFICATION

The goods are supplied in accordance with the Specifications (if any) submitted to the Purchaser and any additions and alterations shall be the subject of an extra charge. Any goods not so specified shall be in accordance with our printed literature or the literature of any of our component suppliers (subject to any modifications made since publication). If we adopt any changes in construction or design of the goods, or in the specification printed in our literature, the Purchaser shall accept the goods so changed in fulfilment of the order.

4. PAYMENT

The buyer shall make payment in full within thirty days from the end of the month in which the invoice is dated. If we receive payment in full on or before the due date we will allow an appropriate settlement discount except where we have quoted a special net price. If payment is not received in full on or before the due date we shall be entitled in addition to the invoice price to:

- (i) payment of a sum equal to any increase in the copper price supplement applicable to the particular goods sold between the date of receipt of order and the date of receipt of payment in full; and
- (ii) interest on any part of the invoice price unpaid after the due date at the rate of 3% per annum over the base rate for the time being of HSBC Bank plc.

5. TIME

We give estimates of delivery dates in good faith and time of delivery is not nor shall be made of the essence of any contract nor shall we be liable for any loss or damage occasioned by delay in delivery.

6. DELIVERY

We deliver free normally by our own vehicles within 25 miles of any of our manufacturing depots. Delivery to any place more than 25 miles from one of our manufacturing depots may be subject to our quoted delivery charges. We reserve the right to make delivery of goods contained in one order by more than one consignment and at different times. Where a period is agreed for delivery and such period is not extended by our Agreement, the Purchaser shall take delivery within that period. If the Purchaser fails to take delivery, we shall be entitled at the Purchaser's risk and expense to store the goods at the Purchaser's premises or elsewhere and to demand payment as if they had been despatched. Off loading at point of delivery shall be the responsibility of and be undertaken by the Purchaser.

7. SHORTAGES OR DAMAGE

Goods must be inspected before signature of delivery note and any damage, shortage or discrepancy noted on the delivery note and the goods returned on the same vehicle. The buyer must also give us immediate written notice of the damage, shortage or discrepancy so that we may prompt investigation.

8. RETURN OF GOODS

Goods may not be returned to the Company except by prior written permission of an authorised officer of the Company and such return shall be subject to payment by the Purchaser of handling and re-stocking charges, transport and all other costs incurred by the Company.

9. COMPANY LIABILITY AND GUARANTEE

9.1. Subject to the terms of these Conditions of Sale and Guarantee Terms Gledhills provide Guarantees in respect of specific products as set out in this clause.

9.2. Each Guarantee is strictly conditional upon the following:-

9.2.1. Complaints must be given to us immediately, before any action is taken, as responsibility cannot be accepted if repairs or renewals are attempted on site without our written approval.

9.2.2. The unit has been installed in accordance with our installation and service instructions and all relevant codes of practice and regulations in force at the time of installation.

9.2.3. All necessary inlet controls and safety valves have been fitted correctly.

9.2.4. The unit has only been used for the storage of potable water supplied from the public mains. The water quality shall be in accordance with European Council Directive 98/83 EC, or revised version at the date of installation, and is not fed with water from a private supply. Particular:

Chloride content: Max. 200 mg/l

Sulphate content: Max. 200 mg/l

Combination chloride/sulphate: Max. 300 mg/l (in total)

9.2.5. Where appropriate the unit has been regularly maintained as detailed in the installation and service instructions

9.2.6. Defects caused by corrosion or scale deposits are not covered by any Guarantee.

9.2.7. Where we agree to rectify any defect we reserve the right to undertake the work on our own premises.

9.2.8. We will not accept any labour charges associated with replacing the unit or parts for any of the following products listed.

9.2.9. If the newly fitted water heater is not in regular use then it must be flushed through with fresh water for at least 15 minutes. Open at least one hot water tap once per week, during a period of at least 4 weeks.

9.3. Guarantees are provided in respect of specified goods supplied by Gledhills as follows:-

(a) Domestic and Commercial Open Vented Cylinders and Tanks.

The storage vessel is guaranteed for ten years and if it proves to be defective either in materials or workmanship, we will either repair or supply replacement at our option with the closest substitute in the case of any obsolete product to any address in Great Britain.

(i) free of all charge during the first year after delivery by us.

(ii) thereafter at a charge of one-tenth of the then current list price and any copper price supplement and delivery charge during the second year after delivery by us and increasing by a further one-tenth on the second and subsequent anniversary of delivery by us.

(b) Domestic Mains Fed Products [Primary Stores]

The storage vessel is guaranteed for five years and if it or any integral pipework as part of the storage vessel assembly proves to be defective either in materials or workmanship, we reserve the right to either repair or supply replacements or the closest possible substitute in the case of any obsolete product and will collect and deliver to any address in England, Wales and Scotland (excluding all Scottish Islands).

(i) free of all charge during the first year after delivery by us.

(ii) thereafter at a charge of one-fifth of the then current list price or any copper price supplement and delivery charge during the second year after delivery by us increasing by a further one-fifth on the second and subsequent anniversary of delivery by us.

(c) StainlessLite Unvented Cylinders

Gledhill guarantee the components including controls, valves and electrical parts for two years from the date of purchase. IT SHOULD BE NOTED THAT THE FACTORY FITTED TEMPERATURE AND PRESSURE RELIEF VALVE MUST NOT BE REMOVED OR ALTERED IN ANY WAY OR THE GUARANTEE WILL NOT BE VALID. GLEDHILL WILL NOT BE RESPONSIBLE FOR ANY CONSEQUENTIAL LOSS OR DAMAGE HOWEVER IT IS CAUSED.

The guarantee for the stainless steel vessel is for twenty five years against material defect or manufacturing faults if the original unit is returned to us **AND PROVIDED THAT:**

(i) It has not been modified, other than by Gledhill.

(ii) It has not been subjected to wrong or improper use or left uncared for.

(iii) It has only been used for the storage of potable water supplied from the public mains, max 200mg/litre chloride.

(iv) It has not been subjected to frost damage.

(v) The benchmark service record is completed after each annual service.

(vi) The unit has been serviced annually.

(vii) Any disinfection has been carried out strictly in accordance with BS6700.

If the stainless steel vessel proves to be defective either in materials or workmanship we reserve the right to either repair or supply replacements or the closest possible substitute in the case of any obsolete product and will collect and deliver to any address in England, Scotland and Wales (excluding all islands):

(i) free of charge during the first year after delivery by us.

(ii) thereafter at a charge of one twenty fifth of the then current list price during the second year after delivery by us and increasing by a further one twenty fifth on the second and subsequent anniversary of delivery by us.

ACTION IN THE EVENT OF FAILURE

We will require the return of a cylinder which develops a leak for inspection. If our examination confirms a failure then an appropriate level of credit against the cost of the original cylinder will be issued in line with the terms of our warranty.

Please note:

- Installation must have been carried out by a licensed specialized company (heating contractor or plumber) following the version of installation instructions in force.

- Gledhill or its representative was given the opportunity to check complaints on site immediately after any defect occurred.

- Confirmation exists that the system was commissioned properly and that the system was checked and maintenance was performed annually by a specialised company licensed for this purpose.

(d) Components of our products other than Storage Vessels and Integral Pipework.

We will either extend to the purchaser the same terms of warranty as we are given by the manufacturer of the component or if the manufacturer does not give any warranty, replace free of charge any component which becomes defective within two years after the date of the delivery by us and is returned to us at the purchaser's expense but we shall not meet the cost of removal or shipping or return of the component or any other cost charges or damages incurred by the purchaser.

9.4.

9.4.1. In respect of goods supplied by us and in respect of any installation work carried out by or on our behalf, our entire liability and the purchaser's sole remedies (subject to the Guarantees) shall be as follows:-

(a) We accept liability for death or personal injury to the extent that it results from our negligence or that of our employees

- (b) Subject to the other provisions of this clause 9 we accept liability for direct physical damage to tangible property to the extent that such damage is caused by our negligence or that of our employees, agents or subcontractors.
- (c) Our total liability to the purchaser over and above any liability to replace under the Guarantees (whether in contract or in tort including negligence) in respect of any one cause of loss or damage claimed to result from any breach of our obligations hereunder, shall be limited to actual money damages which shall not exceed £20,000 provided that such monetary limit shall not apply to any liability on the part of ourselves referred to in paragraph (a) above
- (d) Except as provided in paragraph (a) above but otherwise notwithstanding any provision herein contained in no event shall we be liable for the following loss or damage howsoever caused and even if foreseeable by us or in our contemplation:-
 - (i) economic loss which shall include loss of profits, business revenue, goodwill or anticipated savings
 - (ii) damages in respect of special indirect or consequential loss or damage (other than death, personal injury and damage to tangible property)
 - (iii) any claim made against the purchaser by any other party (save as expressly provided in paragraph (b) above)
- (e) Except in respect of our liability referred to in paragraph (a) above no claim may be made or action brought (whether in contract or in tort including negligence) by the purchaser in respect of any goods supplied by us more than one year after the date of the invoice for the relevant goods.
- (f) Without prejudice to any other term we shall not be liable for any water damage caused directly or indirectly as a result of any leak or other defect in the goods. We cannot control the conditions of use of the goods or the time or manner or location in which they will be installed and the purchaser agrees to be fully responsible for testing and checking all works which include the goods at all relevant times (up to, including and after commissioning) and for taking all necessary steps to identify any leaks and prevent any damage being caused thereby.
- (g) Nothing in these Conditions shall confer on the purchaser any rights or remedies to which the purchaser would not otherwise be legally entitled

10. LOSS OR INJURY

Notwithstanding any other provision contained herein the purchaser's hereby agree to fully indemnify us against any damages losses costs claims or expenses incurred by us in respect of any claim brought against us by any third party for:-

- (a) any loss injury or damage wholly or partly caused by any goods supplied by us or their use.
- (b) any loss injury or damage wholly or partly caused by the defective installation or substandard workmanship or materials used in the installation of any goods supplied by us.
- (c) any loss injury or damage in any way connected with the performance of this contract.
- (d) any loss resulting from any failure by the purchaser to comply with its obligations under these terms as to install and/or check works correctly.

PROVIDED that this paragraph will not require the purchaser to indemnify us against any liability for our own acts of negligence or those of our employees agents or sub-contractors

FURTHER in the case of goods supplied by us which are re-sold and installed by a third party by the purchaser it will be the sole responsibility of the purchaser to test the goods immediately after their installation to ensure that inter alia they are correctly installed and in proper working order free from leaks and are not likely to cause any loss injury or damage to any person or property.

11. VARIATION OF WARRANTY AND EXCLUSION

Should our warranty and exclusion be unacceptable we are prepared to negotiate for variation in their terms but only on the basis of an increase in the price to allow for any additional liability or risk which may result from the variation. Purchasers are advised to insure against any risk or liability which they may incur and which is not covered by our warranty.

12. ADVICE

Any advice or assistance given by the Company is provided without charge and is in good faith without undertaking, representation or warranty, and we will not accept any liability, whether consequential or compensatory, for advice or assistance given.

13. RISK AND RETENTION OF TITLE

- (a) goods supplied by us shall be at the Purchaser's risk immediately upon delivery to the Purchaser or into custody on the Purchaser's behalf or to the Purchaser's Order. The Purchaser shall effect adequate insurance of the goods against all risks to the full invoice value of the goods, such insurance to be effective from the time of delivery until property in the goods shall pass to the Purchaser as hereinafter provided.
- (b) property in the goods supplied hereunder will pass to the Purchaser when full payment has been made by the Purchaser to us for :-
 - (i) the goods of the subject of this contract.
 - (ii) all other goods the subject to of any other contract between the Purchaser and us which, at the time of payment of the full price of the goods sold under this contract, have been delivered to the Purchaser but not paid for in full.
- (c) until property in the goods supplied hereunder passes to the Purchaser in accordance with paragraph (2) above.
 - (i) the Purchaser shall hold the goods in a fiduciary capacity for us and shall store the same separately from any other goods in the Purchaser's possession and in a manner which enables them to be identified as our goods.
 - (ii) the Purchaser shall immediately return the goods to us should our authorised representative so request. All the necessary incidents associated with a fiduciary relationship shall apply.
- (d) the Purchaser's right to possess the goods shall cease forthwith upon the happening of any of the following events, namely :-
 - (i) if the Purchaser fails to make payment in full for the goods within the time stipulated in clause 4 hereof.
 - (ii) if the Purchaser, not being a company, commits any act of bankruptcy, makes a proposal to his or her creditors for a compromise or does anything which would entitle a petition for a Bankruptcy Order to be presented.
 - (iii) if the Purchaser, being a company, does anything or fails to do anything which would entitle an administrator or an administrative receiver or a receiver to take possession of any assets or which would entitle any person to present a petition for winding up or to apply for an administration order.
- (e) the Purchaser hereby grants to us an irrevocable licence to enter at any time any vehicle or premises owned or occupied by the Purchaser or in the possession of the Purchaser for the purposes of repossessing and recovering any such goods the property in which has remained in us under paragraph (2) above. We shall not be responsible for and the Purchaser will indemnify us against liability in respect of damage caused to

any vehicle or premises in such repossession and removal being damaged which it was not reasonably practicable to avoid.

- (f) notwithstanding paragraph (3) hereof and subject to paragraph (7) hereof, the Purchaser shall be permitted to sell the goods to third parties in the normal course of business. In this respect the Purchaser shall act in the capacity of our commission agent and the proceeds of such sale :-
 - (i) shall be held in trust for us in a manner which enables such proceeds to be identified as such, and:
 - (ii) shall not be mixed with other monies nor paid into an overdrawn bank account.
- We, as principal, shall remunerate the Purchaser as commission agent a commission depending upon the surplus which the Purchaser can obtain over and above the sum, stipulated in this contract of supply which will satisfy us.
- (g) in the event that the Purchaser shall sell any of the goods pursuant to clause (6) hereof, the Purchaser shall forthwith inform us in writing of such sale and of the identity and address of the third party to whom the goods have been sold.
- (h) if, before property in the goods passes to the Purchaser under paragraph (2) above the goods are or become affixed to any land or building owned by the Purchaser it is hereby agreed and declared that such affixation shall not have the effect of passing property in the goods to the Purchaser. Furthermore if, before property in the goods shall pass to the Purchaser under paragraph (2) hereof, the goods are or become affixed to any land or building (whether or not owned by the Purchaser), the Purchaser shall:-
 - (i) ensure that the goods are capable of being removed without material injury to such land or building.
 - (ii) take all necessary steps to prevent title to the goods from passing to the landlord of such land or building.
 - (iii) forthwith inform us in writing of such affixation and of the address of the land or building concerned.

The Purchaser warrants to repair and make good any damage caused by the affixation of the goods to or their removal from any land or building and to indemnify us against all loss damage or liability we may incur or sustain as a result of affixation or removal.

- (i) in the event that, before property in the goods has passed to the Purchaser under paragraph (2) hereof, the goods or any of them are lost, stolen, damaged or destroyed :-
- (ii) the Purchaser shall forthwith inform us in writing of the fact and circumstances of such loss, theft, damage or destruction.
- (iii) the Purchaser shall assign to us the benefit of any insurance claim in respect of the goods so lost, stolen, damaged or destroyed.

14. NON-PAYMENT

If the Purchaser shall fail to make full payment for the goods supplied hereunder within the time stipulated in clause 4 hereof or be in default of payment for any other reason then, without prejudice to any of our other rights hereunder, we shall be entitled to stop all deliveries of goods and materials to the Purchaser, including deliveries or further deliveries of goods under this contract. In addition we shall be entitled to terminate all outstanding orders.

15. VALUE ADDED TAX

All prices quoted are exclusive of Value Added Tax which will be charged at the rate ruling at the date of despatch of invoice.

16. TRADE SALES ONLY

We are only prepared to deal with those who are not consumers within the terms of the Unfair Contract Terms Act 1977, the Sale of Goods Act 1979 and the Supply of Goods and Services Act 1982. Accordingly any person who purchases from us shall be deemed to have represented that he is not a consumer by so purchasing.

17. JURISDICTION

The agreement is subject to English law for products delivered in England and Scottish law for products delivered in Scotland and any dispute hereunder shall be settled in accordance therewith dependent upon the location.

18. PRODUCT DEVELOPMENT

Gledhill have a policy of continuous product development and may introduce product modifications from time to time.

MAINS PRESSURE HOT WATER STORAGE SYSTEM COMMISSIONING CHECKLIST

This Commissioning Checklist is to be completed in full by the competent person who commissioned the storage system as a means of demonstrating compliance with the appropriate Building Regulations and then handed to the customer to keep for future reference.

Failure to install and commission this equipment to the manufacturer's instructions may invalidate the warranty but does not affect statutory rights.

Customer name:										Telephone number:														
Address:																								
Cylinder Make and Model																								
Cylinder Serial Number																								
Commissioned by (PRINT NAME):										Registered Operative ID Number														
Company name:										Telephone number:														
Company address:																								
										Commissioning date:														
To be completed by the customer on receipt of a Building Regulations Compliance Certificate*:																								
Building Regulations Notification Number (if applicable)																								
ALL SYSTEMS PRIMARY SETTINGS (indirect heating only)																								
Is the primary circuit a sealed or open vented system?										Sealed					Open									
What is the maximum primary flow temperature?															°C									
ALL SYSTEMS																								
What is the incoming static cold water pressure at the inlet to the system?															bar									
Has a strainer been cleaned of installation debris (if fitted)?										Yes					No									
Is the installation in a hard water area (above 200ppm)?										Yes					No									
If yes, has a water scale reducer been fitted?										Yes					No									
What type of scale reducer has been fitted?																								
What is the hot water thermostat set temperature?															°C									
What is the maximum hot water flow rate at set thermostat temperature (measured at high flow outlet)?															l/min									
Time and temperature controls have been fitted in compliance with Part L of the Building Regulations?															Yes									
Type of control system (if applicable)										Y Plan					S Plan					Other				
Is the cylinder solar (or other renewable) compatible?										Yes					No									
What is the hot water temperature at the nearest outlet?															°C									
All appropriate pipes have been insulated up to 1 metre or the point where they become concealed															Yes									
UNVENTED SYSTEMS ONLY																								
Where is the pressure reducing valve situated (if fitted)?																								
What is the pressure reducing valve setting?															bar									
Has a combined temperature and pressure relief valve and expansion valve been fitted and discharge tested?										Yes					No									
The tundish and discharge pipework have been connected and terminated to Part G of the Building Regulations															Yes									
Are all energy sources fitted with a cut out device?										Yes					No									
Has the expansion vessel or internal air space been checked?										Yes					No									
THERMAL STORES ONLY																								
What store temperature is achievable?															°C									
What is the maximum hot water temperature?															°C									
ALL INSTALLATIONS																								
The hot water system complies with the appropriate Building Regulations															Yes									
The system has been installed and commissioned in accordance with the manufacturer's instructions															Yes									
The system controls have been demonstrated to and understood by the customer															Yes									
The manufacturer's literature, including Benchmark Checklist and Service Record, has been explained and left with the customer															Yes									
Commissioning Engineer's Signature																								
Customer's Signature																								
(To confirm satisfactory demonstration and receipt of manufacturer's literature)																								

*All installations in England and Wales must be notified to Local Authority Building Control (LABC) either directly or through a Competent Persons Scheme. A Building Regulations Compliance Certificate will then be issued to the customer.



While this Checklist can be used for any installation covered by its description, only appliances manufactured by Scheme Members will be covered by the rules and requirements of the Benchmark Scheme.

SERVICE RECORD

It is recommended that your hot water system is serviced regularly and that the appropriate Service Record is completed.

Service Provider

Before completing the appropriate Service Record below, please ensure you have carried out the service as described in the manufacturer's instructions.

SERVICE 01		Date:	SERVICE 02		Date:
Engineer name:		Engineer name:		Engineer name:	
Company name:		Company name:		Company name:	
Telephone No:		Telephone No:		Telephone No:	
Comments:		Comments:		Comments:	
.....		
.....		
.....		
.....		
Signature		Signature		Signature	
SERVICE 03		Date:	SERVICE 04		Date:
Engineer name:		Engineer name:		Engineer name:	
Company name:		Company name:		Company name:	
Telephone No:		Telephone No:		Telephone No:	
Comments:		Comments:		Comments:	
.....		
.....		
.....		
.....		
Signature		Signature		Signature	
SERVICE 05		Date:	SERVICE 06		Date:
Engineer name:		Engineer name:		Engineer name:	
Company name:		Company name:		Company name:	
Telephone No:		Telephone No:		Telephone No:	
Comments:		Comments:		Comments:	
.....		
.....		
.....		
.....		
Signature		Signature		Signature	
SERVICE 07		Date:	SERVICE 08		Date:
Engineer name:		Engineer name:		Engineer name:	
Company name:		Company name:		Company name:	
Telephone No:		Telephone No:		Telephone No:	
Comments:		Comments:		Comments:	
.....		
.....		
.....		
.....		
Signature		Signature		Signature	
SERVICE 09		Date:	SERVICE 10		Date:
Engineer name:		Engineer name:		Engineer name:	
Company name:		Company name:		Company name:	
Telephone No:		Telephone No:		Telephone No:	
Comments:		Comments:		Comments:	
.....		
.....		
.....		
.....		
Signature		Signature		Signature	

Protect your Gledhill product after your initial warranty period



On expiry of your initial warranty period, Gledhill Response Limited would be pleased to provide further customer support with a range of services including:

- Low cost annual repair and maintenance contracts direct from Gledhill
- Annual servicing and safety checks
- Expert response to 'out of warranty' breakdowns at fixed charges

Please call 08445 679898 or visit www.gledhill.net for further details



For any spare part requirements on this product simply scan the QR code using your smart phone app or go to www.gledhill-spares.net



Gledhill Building Products Limited

Sycamore Estate, Squires Gate, Blackpool FY4 3RL Tel: 01253 474550 Fax: 01253 474551 sales@gledhill.net
After Sales Technical Support Tel: 01253 474584

Gledhill Building Products produce cylinders for use with a wide range of heat sources including;

- Gas and oil boilers
- Electricity
- Air source heat pumps
- Ground source heat pumps
- Solar energy
- Wood burning stoves

Further information on Gledhill products can be found at www.gledhill.net



FM 02057



Due to a programme of continuous improvement Gledhill Building Products reserve the right to modify products without prior notice. It is advisable to check the product technical detail by using the latest design and installation manuals available from our technical support team or on our website. It is an offence to copy or adapt this document without consent of the owner.