

# Torrent MultiFuelStore HP

Thermal store for use with a heat pump to provide heating and hot water

## Design, Installation & Servicing Instructions



**Models covered in this manual**

Torrent MultiFuelStore HP 180-450 litres  
Torrent MultiFuelStore HP Solar 180-450 litres

## ISSUE 3: 10-10

Section	Page
<b>DESIGN</b>	
Introduction	3
System Design	8
<b>INSTALLATION</b>	
Installation	12
Commissioning	18
<b>SERVICING</b>	
Short Parts List	19
<b>APPENDIX</b>	
Appendix A	20
Appendix B	21
<b>BENCHMARK</b>	
Commissioning Checklist	22
Service Record	23
Notes	24
Terms & Conditions	26



Benchmark places responsibilities on both manufacturers and installers. The purpose is to ensure that customers are provided with the correct equipment for their needs, that it is installed, commissioned and serviced in accordance with the manufacturers instructions by competent persons and that it meets the requirements of the appropriate Building Regulations. The Benchmark Checklist can be used to demonstrate compliance with Building Regulations and should be provided to the customer for future reference.

Installers are required to carry out installation, commissioning and servicing work in accordance with the Benchmark Code of Practice which is available from the Heating and Hot Water Industry Council who manage and promote the Scheme. Visit [www.centralheating.co.uk](http://www.centralheating.co.uk) for more information.

Gas Safe operates a Self Certification Scheme for gas heating appliances.

**British patent nos. 1358166, 2136099  
British patent applications published under  
nos. 2136099, 2153503, 2153504, 8516025**

**This product is manufactured under an ISO  
9001:2008 Quality System audited by BSI.**

**Gledhill's first priority is to give a high quality  
service to our customers.**

**Quality is built into every Gledhill product  
and we hope you get satisfactory service  
from Gledhill.**

**If not please let us know.**

These instructions should be read in conjunction with the Installation and Servicing Instructions issued by the manufacturers of the heat pump used.

Any water distribution and central heating installation must comply with the relevant recommendations of the current version of the Regulations and British Standards listed below:-

Gas Safety Regulations  
Building Regulations  
I.E.E. Requirements for Electrical Installations  
Water Regulations

#### **British Standards**

BS6798, BS5449, BS5546, BS5440:1, BS5440:2, CP331:3, BS6700, BS5258, BS7593:1993 and BS7671.

It must be installed by a competent person as stated in the Gas Safety Regulations where applicable. Manufacturers notes must NOT be taken as over-riding statutory obligations.

Torrent MultiFuelStore HP is not covered by Section G3 of the current Building Regulations but the installation is notifiable to building control unless it is carried out under an approved competent person self-certification scheme.

Although the secondary supply (domestic) is at mains pressure, it is not necessary to fit an expansion chamber, pressure or temperature relief valve, the plumbing should allow any unusual build up of pressure to be relieved at the ball valve.

The information in this manual is provided to assist generally in the selection of equipment. The responsibility for the selection and specification of the equipment must however remain that of the customer and any Designers or Consultants concerned with the design and installation.

**Please Note:** We do not therefore accept any responsibility for matters of design, selection or specification or for the effectiveness of an installation containing one of our products unless we have been specifically requested to do so.

**All goods are sold subject to our Conditions of Sale and Warranty Terms, which are set out at the rear of this manual.**

In the interest of continuously improving the Torrent MultiFuelStore HP range, Gledhill Building Products Ltd reserve the right to modify the product without notice, and in these circumstances this document, which is accurate at the time of printing, should be disregarded. It will however be updated as soon as possible after the change has occurred.

#### **Description**

The Torrent MultiFuelStore HP is a directly heated, open vented thermal store designed for use with an air source or a ground source heat pump. Although the thermal store is open vented, the mains pressure hot water is heated instantaneously by means of heat exchangers inside the store (Figures 1 & 2).

The Torrent MultiFuelStore HP range of primary thermal stores are only suitable for open vented heating systems but they provide mains pressure hot water without the requirements of a pressure and temperature relief valve. Notification to Building Control to comply with Section G3 of the Building Regulations is therefore not required. This is because the thermal store is vented in the normal way and unlike an unvented storage cylinder, the Torrent MultiFuelStore HP range require no regular maintenance or annual inspection. This reduces running costs for the home-owner while offering high performance showers and high flow rates to fill baths rapidly.

Because this product does not require a safety discharge from the temperature and pressure relief valve, any installation will be easy to incorporate into the building and will not suffer from the problems associated with using soil stacks to take the high temperature discharge from unvented cylinders.

# DESIGN

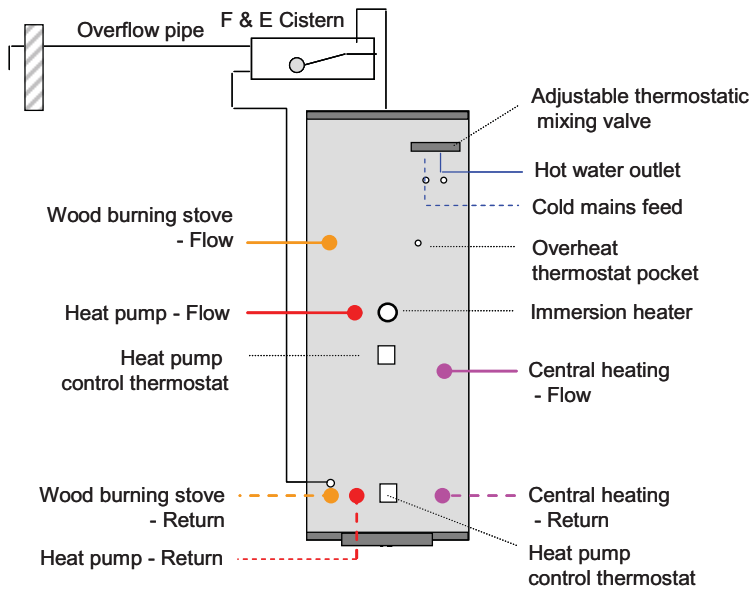

Figure 1 : Torrent MultiFuelStore HP

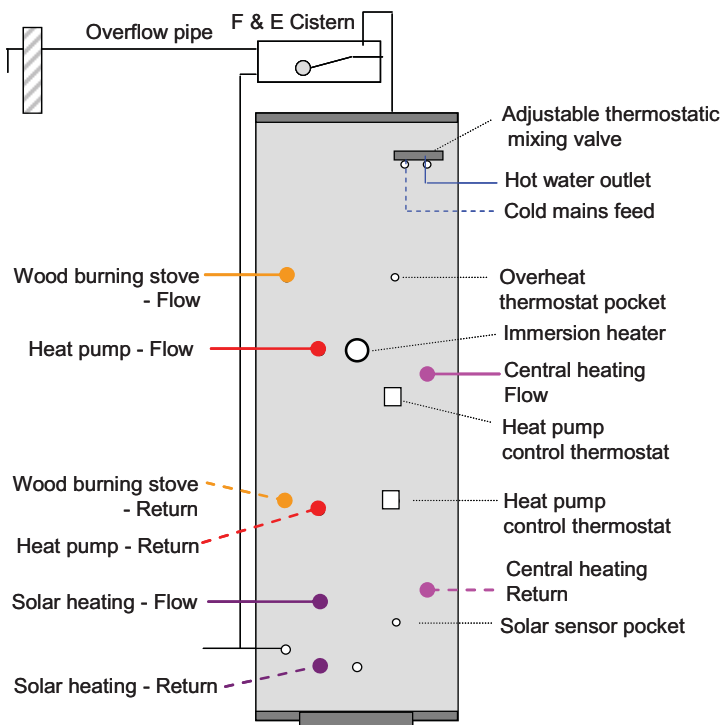

Figure 2 : Torrent MultiFuelStore HP Solar

## Torrent MultiFuelStore HP Models

The Torrent MultiFuelStore HP is insulated to a very high standard using high density HCFC free foam cased in a steel shell and therefore has an ozone deletion potential (ODP) of zero and a global warming potential (GWP) of 1.

The specification of the models is listed in table 1 and the model selection guide is shown in table 2.

The hot water performance of the Torrent MultiFuelStore HP depends upon the store temperature as shown in figures 3, 4 and 5.

The suggested model sizes are based on typical hot water usage and the store charged to about 65°C. If the store charge temperature is going to be lower, then a larger model should be considered.

This is especially important where the heat pump alone is unable to charge the store to 65°C as is likely to be the case with a heat pump. If the immersion element is used to raise the temperature of the store, then a suitable control system should be used to ensure the immersion element does not operate until the heat pump has raised the store to the maximum temperature, or the overall efficiency of the system will be reduced.

Additional thermostat pockets are provided for this purpose and a schematic wiring diagram is shown in figure 10.

When selecting a solar model, it is important to check that the dedicated solar volume (shown in table 1) is suitable for the floor area of the dwelling to ensure compliance with the Building Regulations.

The Torrent MultiFuelStore HP models are designed to be heated directly by the heat pump and the central heating can be supplied directly from the heat pump as shown in figure 6 or from a thermal store as shown in figure 7.

The Torrent MultiFuelStore HP-solar models are designed to be heated directly by the heat pump and indirectly by the solar thermal system as shown schematically in figures 8 and 9.

All models are fitted with a 3kW immersion heater for boosting the store temperature (if necessary) and some models can also be connected to a solid fuel appliance (e.g. wood burning stove) as well as the heat pump. All Torrent MultiFuelStore HP models are supplied with following equipment as standard: -

- 1 feed and expansion cistern complete with ball valve and float
- 1 3kW immersion heater (230Vac, 50Hz)
- 2 store thermostats

**Figure 3 : Hot water performance of T180HP at 15 - 17 l/min draw off rate**

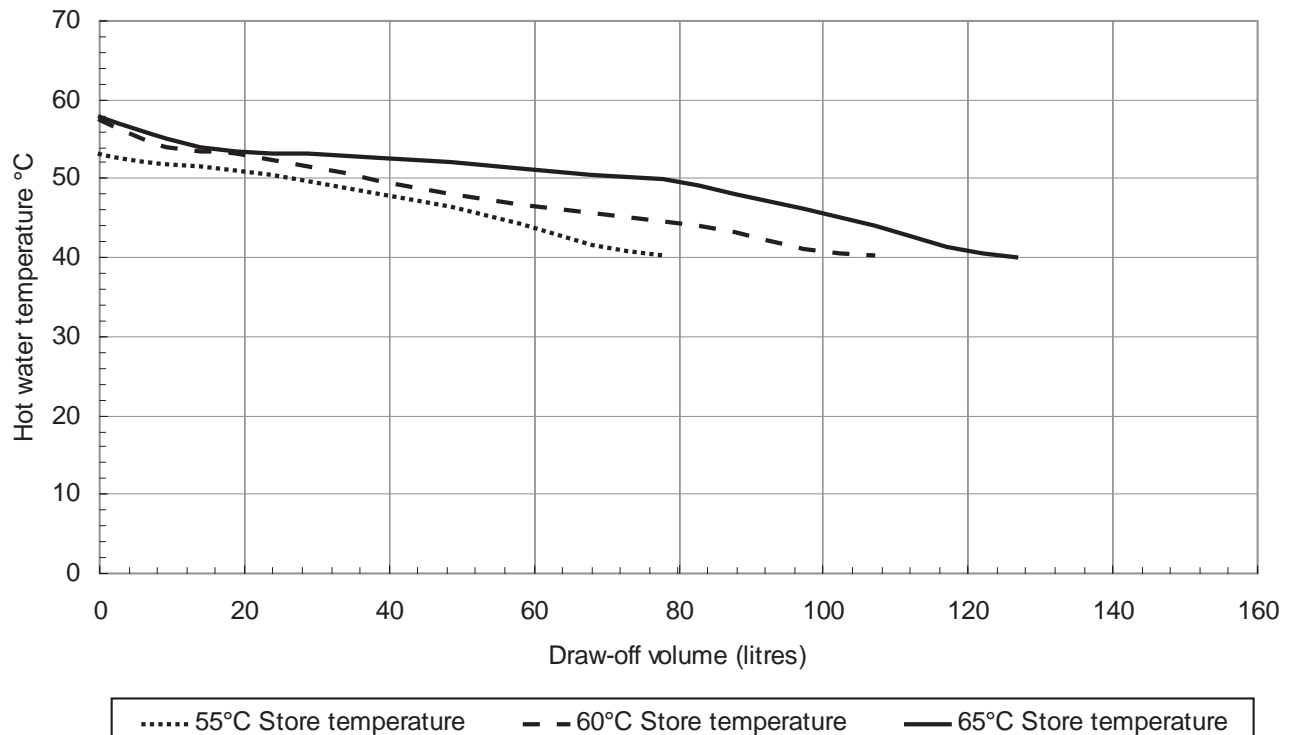

The performance figures shown above for the 180 litre store are increased accordingly as the cylinder capacity increases. The graph illustrates the increase in volume that can be achieved by the use of the auxiliary heat source.

A 15 - 17 litre/min flow restrictor is fitted to the Torrent MultiFuelStore HP hot water supply outlet on commissioning. Check that the hot water flow does not exceed 17 litre/min.

**Particular attention needs to be paid to the product size selection. If the intention is for the majority of the hot water to be provided by the heat pump with minimal use of the auxiliary immersion element then it may be necessary to choose a larger store.**

# DESIGN

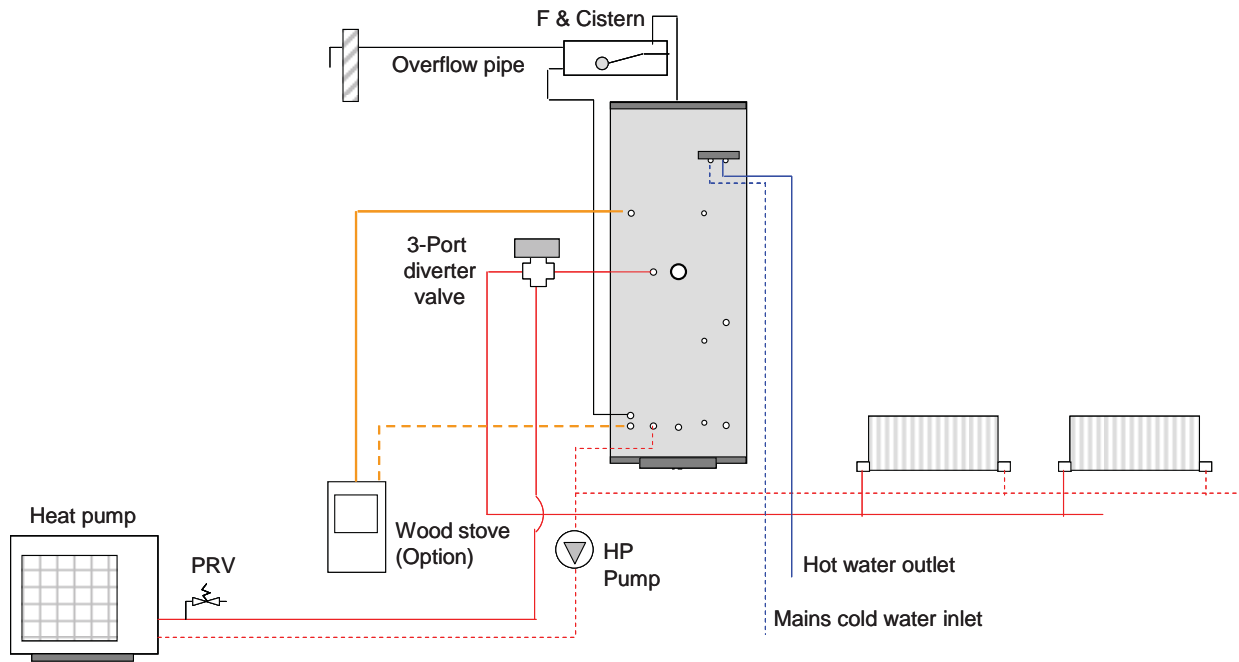

Figure 6: Typical Torrent<sup>HP</sup> system configuration with an optional wood burning stove and central heating supplied directly from the heat pump.

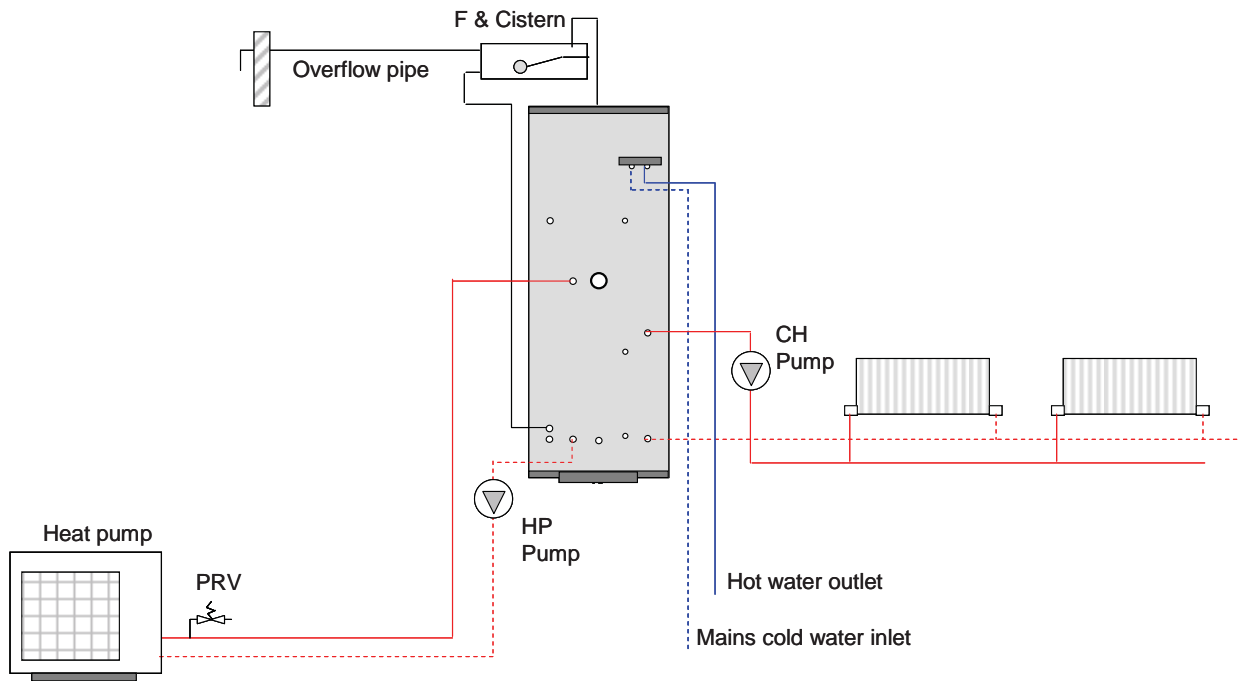

Figure 7: Typical Torrent<sup>HP</sup> system configuration with central heating supplied from a thermal store

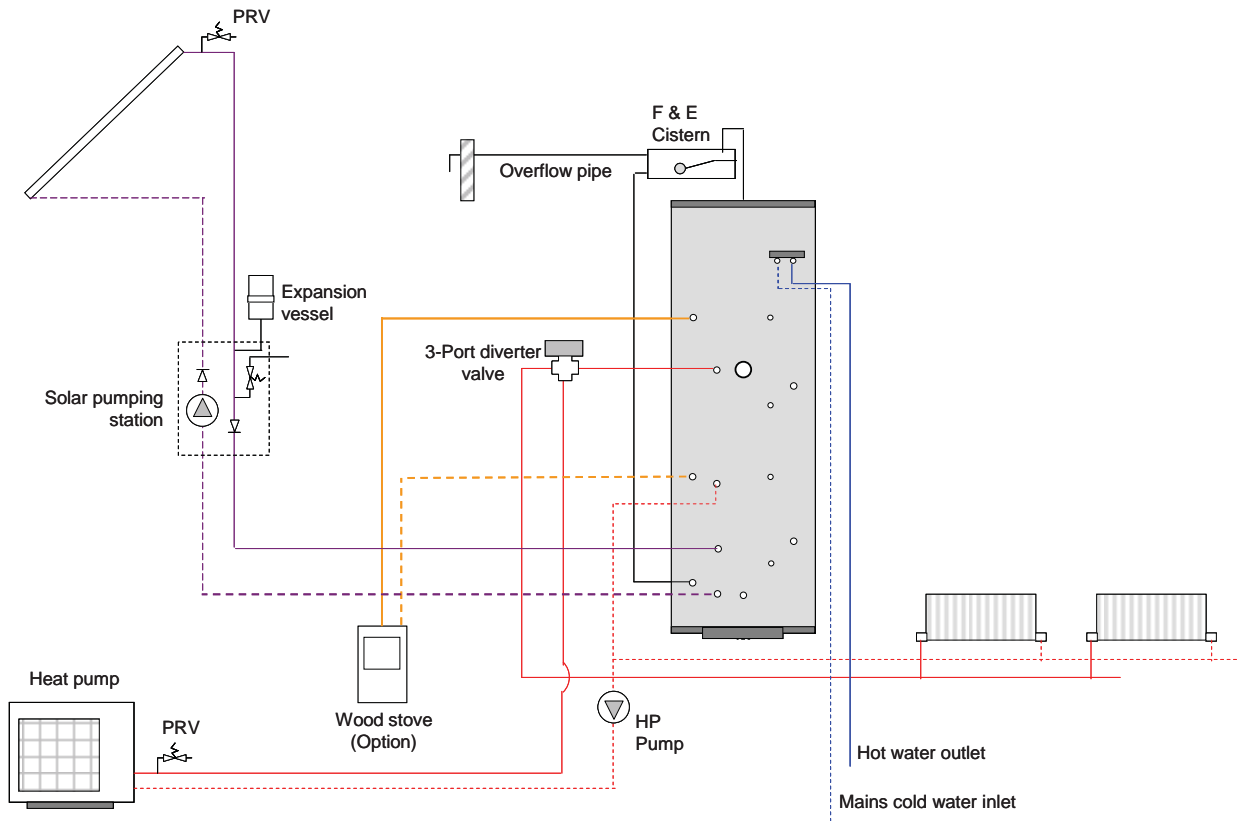

Figure 8: Typical TorrentHP-sol system configuration with optional wood burning stove and central heating supplied directly from the heat pump.

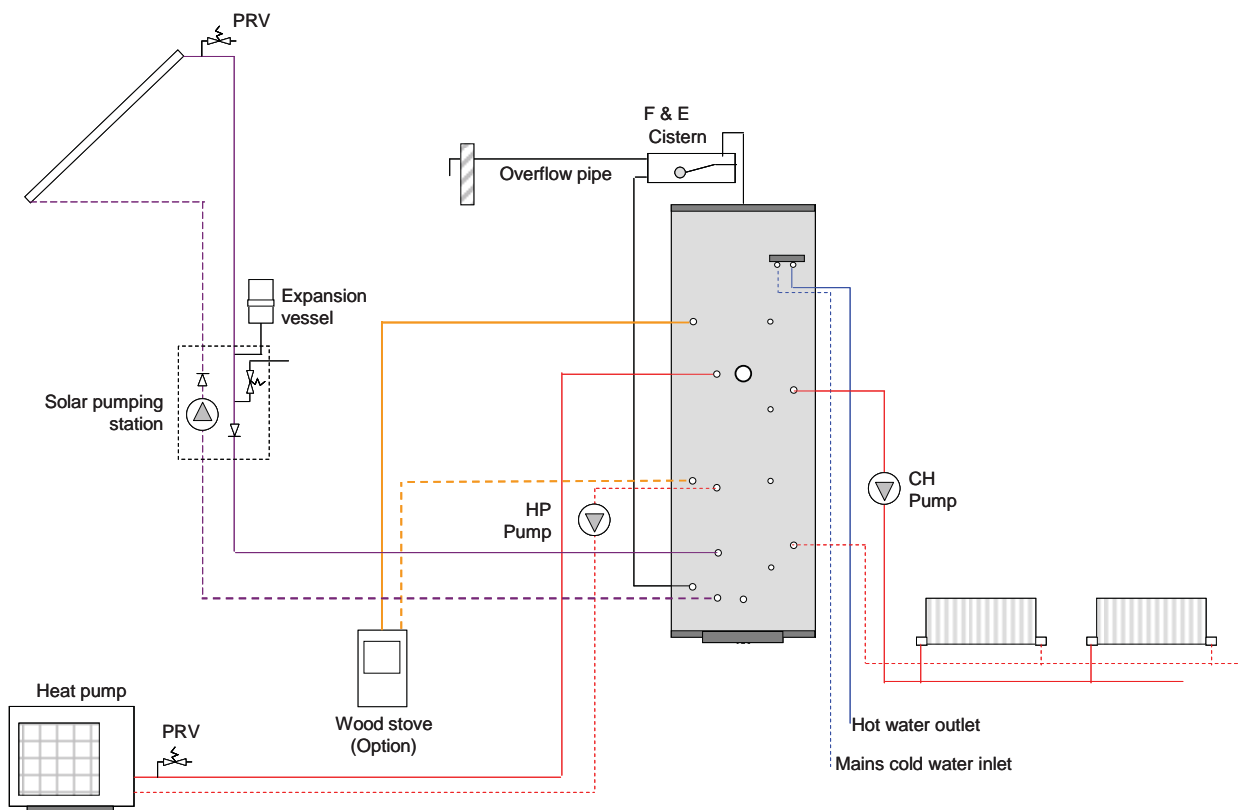

Figure 9: Typical TorrentHP-sol system configuration with wood burning stove option and central heating supplied from the thermal store

# DESIGN

## General

- All Torrent MultiFuelStore HP models covered by this manual, are only suitable for open vented primary (heat pump and space heating) circuits. Therefore the pressure in the primary circuit depends upon the height of the feed and expansion cistern and could be as low as 0.20 bar. Therefore ensure that the heat pump selected will operate at primary circuit pressures e.g. it is not fitted with a non-adjustable low system pressure switch.
- The heat pumps normally operate at lower temperature difference (5-10°C) between flow and return than that for a gas boilers (10-20°C) resulting in higher flow rates in the heat pump primary circuit. Therefore it is important that the primary pipework connecting the heat pump to the thermal store and the circulating pump are sized to achieve flow rates recommended by the heat pump manufacturer.
- The efficiency (i.e. coefficient of performance, COP) of a heat pump depends upon the primary flow and return temperatures and it is generally higher at lower primary circuit temperatures. Also the heat pumps normally operate at lower flow temperatures; typically 45-55°C compared with 75-80°C for gas boilers. Therefore if traditional radiators are used then, these should be oversized in accordance with the heat pump manufacturers recommendations.
- For optimum operational efficiency and hence lower running costs, a low temperature space heating (e.g. under-floor heating) system should be used where feasible.

## Heat Pump Sizing

- The efficiency (i.e. coefficient of performance, COP) of an air source heat pump and hence its heat output generally decreases as the ambient air temperature decreases. Therefore, this factor should be taken into account when sizing and selecting the heat pump.
- The design space heating load of a dwelling should be calculated in accordance with BS 5449. The allowance for domestic hot water heating (shown in table below), depends upon the operating mode. For example, if the system is designed to operate with priority for domestic hot water, then no additional allowance for hot water is required for sizing the heat pump.

Allowance for Domestic Hot Water Heating		
Model	Allowance for Domestic Hot Water	
	Hot Water Priority Mode	Flow Share Mode
THP180-SOL	0kW	1.5kW
THP180 THP210-SOL	0kW	2.5kW
THP210 THP250-SOL	0kW	3.0kW
THP250 THP300-SOL	0kW	3.5kW
THP300 THP450-SOL	0kW	4.0kW
THP450-SOL	0kW	5.0kW

## Heating System Arrangement

The Torrent MultiFuelStore HP models are designed to be heated directly by an air or a ground source heat pump and the space heating can be supplied directly from the heat pump circuit as shown in figures 6 and 8 or from the thermal store as shown in figures

7 and 9. The selection between the two options will depend upon the operating characteristics of the heat pump, type of heating system and control strategy. For general guidance: -

- If the heat pump requires a buffer for operation; for example to reduce rapid cycling etc, then the system would benefit if the heating system is supplied from the thermal store (figures 7 and 9). In this configuration, the operation of the heat pump is only controlled by the store thermostat(s).
- If the heat pump is multi-stage or modulating type or has weather compensating controls, then the space heating circuit should be supplied directly from the heat pump as shown in figures 6 and 8. In this system configuration, the thermal store is only used for producing hot water.
- A hybrid system arrangement can also be used (not shown). For example; a low temperature weather compensated heating circuit e.g. under floor heating can be supplied directly from the heat pump circuit and constant temperature e.g. towel rails can be supplied from the thermal store.

## Ballvalve/overflow - All Models

Where the whole of the heating system is supplied from the thermal store, figures 7 and 9, then a ballvalve and overflow should be fitted in the feed and expansion tank.

Where the heat pump supplies the heating circuit directly, figures 6 and 8, then fitting a ballvalve and overflow is optional if it is practical on occasions to manually fill the store. However, fitting a ballvalve and overflow will eliminate the need for the householder to undertake this task and is therefore preferable. If the siting of the Torrent MultiFuelStore HP makes it difficult to fit an overflow then the 'manual fill' option can be used. In all cases, if a ballvalve is fitted, then an overflow/warning pipe must always be fitted.

## Plastic Pipe Work

All the recommendations with regard to the heating systems in this manual are generally based on BS/EN Standard copper pipework and fittings. However plastic pipework system can be used in place of copper as long as:

- The chosen system is recommended for use in domestic heating systems by the manufacturers and it is installed fully in accordance with their recommendations.
- The design criterion of the plastic system is at least equivalent to the use of BS/EN Standard copper pipework and fittings.



- The barrier pipework for these systems is recommended.

## Use In Hard Water Areas - All Models

The patented design of the heat exchange module is such that the turbulence through the coil slows down the formation of scale in even the hardest water conditions, at normal operating pressures.

## Scale Protection

The Building Regulations approved document L1A and L1B and the requirements set out in the 'Domestic Heating Compliance Guide' specify that "where the mains water hardness exceed 200ppm provision should be made to treat the feed water to the water heaters and the hot water circuit of combination boilers to reduce rate of accumulation of lime scale".

To comply with this requirement, the hardness of the mains water should be checked by the installer and if necessary a suitable in-line scale inhibitor device should be specified for hardness levels between 200 and 300ppm (mg/l).

It is important that where the supply to the Torrent is in 22mm the in-line scale inhibitor is also 22mm. In practice servicing is not normally required but in hard water areas requirements can be considered similar to those needed for instantaneous or 'combi' appliances.

The installation of the scale inhibitor should be in accordance with the manufacturers instructions and with the Water Byelaws.

Where the water hardness level is 300ppm (mg/l) and above, the optional phosphate type inhibitor should be specified and fitted at a suitable point in the cold water supply to the appliance.

## Water Treatment And Frost Protection

Although the Torrent MultiFuelStore HP has no special water treatment requirements, the radiators and other parts of the circuit will require the application of a scale and corrosion inhibitor. The heat pump and the external connecting pipework will also require protection against freezing. For this reason, a combined antifreeze and inhibitor product such as Fernox Alphi 11 must be used (see Fernox Alphi 11 datasheet in Appendix B).

The volumes and concentration should be calculated in accordance with the manufacturers instructions and when calculating the system volume i.e. the water content, the volume of the Torrent MultiFuelStore HP should be taken into account (see table).

In all Torrent MultiFuelStore HP models, treating the primary water will not contaminate the domestic hot water.

## Secondary Hot Water Circulation

If the length of the hot water draw-off pipework is excessive and the delivery time will be more than 60 seconds before hot water is available at the tap, you may wish to consider using trace heating to the hot water pipework such as the Raychem HWAT system. Also a conventional pumped secondary circulation system (shown below) can be used with any model of the Torrent.

It is important that the cold water pipework is adequately separated and protected from any heating from the hot water pipework to ensure that the water remains cold and of drinking water quality.

If secondary circulation is used, there is a possibility that excessively hot temperatures may be experienced in the hot water supply pipework due to the blending valve not being able to mix with cold water because the water is always supplied hot. A pipe thermostat is incorporated in the circuitry which cuts the supply to the pump when the water in the return pipe reaches the set temperature of the blending valve.

Secondary circulation pipework must be insulated to prevent energy loss in both heated and unheated areas.

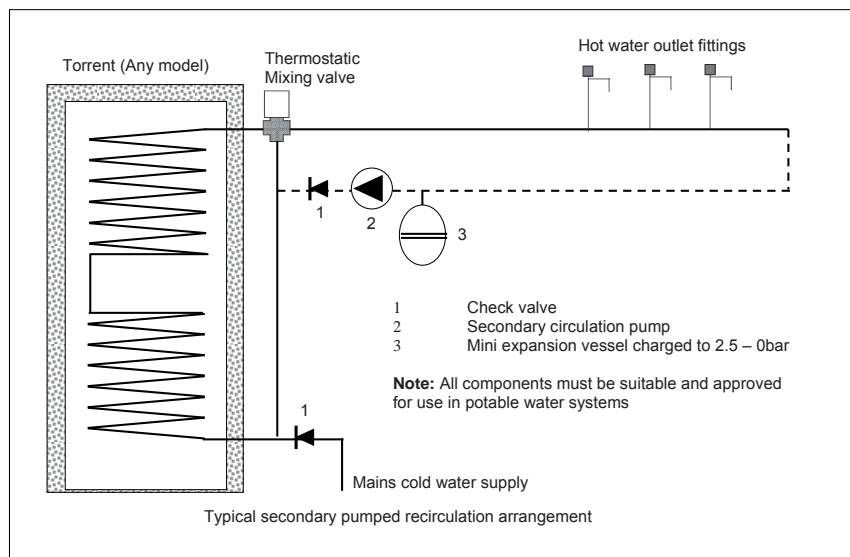

# DESIGN

Table 1a - Technical Specification of Torrent MultiFuelStore HP							
			THP180	THP210	THP250	THP300	THP450
Nominal volume		litres	191	224	250	300	450
Overall height		mm	1440	1675	1600	1800	1800
Overall diameter		mm	555	555	655	655	855
Minimum cupboard size	Height	mm	1990	2225	2150	2350	2350
	Width	mm	680	680	780	780	780
	Depth	mm	680	680	780	780	780
Weight	Empty	kg	54	58	63	67	77
	Full	kg	245	282	313	367	527
Standby heat loss rate		kW/24h	1.82	2.08	2.25	2.41	2.85
Maximum working pressure	Open vented store	mWG	5.0	5.0	5.0	5.0	5.0
	Space heating and heat pump primary circuits	mWG	5.0	5.0	5.0	5.0	5.0
	Solar heat exchanger	bar	6.0	6.0	6.0	6.0	6.0
Connections	Open vent	mm	22	22	28	28	28
	Cold feed	mm	15	15	15	15	15
	CH flow and return	mm	22	22	28	28	35
	HP flow and return	mm	22	22	28	35	35
	Wood burning stove flow and return	mm	28	28	28	28	28
	Drain	in	R½"	R½"	R½"	R½"	R½"
Thermostat / sensor pockets	Heat pump control thermostat pockets 1 & 2	in	R½"	R½"	R½"	R½"	R½"
	Over heat thermostatic pocket	mm	8.5 ID	8.5 ID	8.5 ID	8.5 ID	8.5 ID
3kW, 230Vac, 50Hz immersion heaters - type 2			1	1	1	2	2
Hot water draw off volume at 35°C temperature rise <sup>(1)</sup>	Store charged at 55°C	litres	90	100	118	136	193
	Store charged at 60°C	litres	130	140	165	195	275
	Store charged at 65°C	litres	155	180	210	240	350
Notes							
(1) Hot water draw-off rate 15-17 l/min for 180/210, 17-20 l/min for 250/300 and 22-25 l/min for 450							

Table 2a - Model selection guide					
Bedrooms	2-3	2-3	3-4	3-4	4-5
Bathrooms	1	1	2	2	3
En-suite showers	1	2	1	2	2
Torrent MultiFuelStore HP model	THP180	THP210	THP250	THP300	THP450

**Table 1b - Technical Specification of Torrent MultiFuelStore HP Solar**

			THP180 sol	THP210 sol	THP250 sol	THP300 sol	THP450 sol
Nominal volume		litres	171	223	250	300	450
Dedicated solar volume		litre	62	72	80	95	140
Overall height		mm	1650	1675	1600	1800	1800
Overall diameter		mm	555	555	600	600	700
Minimum cupboard size	Height	mm	2200	2225	2150	2350	2350
	Width	mm	680	680	780	780	780
	Depth	mm	680	680	780	780	780
Weight	Empty	kg	62	63	66	71	81
	Full	kg	233	286	316	371	531
Maximum dwelling floor area <sup>(1)</sup>		m <sup>2</sup>	49	60	90	105	200
Maximum net collector area <sup>(2)</sup>		m <sup>2</sup>	2.4	2.9	3.2	3.8	5.6
Surface area of solar heat exchanger <sup>(3)</sup>		m <sup>2</sup>	1.31	1.31	1.74	1.74	2.18
Standby heat loss rate		kW/24h	1.82	2.08	2.25	2.41	2.85
Maximum working pressure	Open vented store	mWG	5.0	5.0	5.0	5.0	5.0
	Space heating and heat pump primary circuits	mWG	5.0	5.0	5.0	5.0	5.0
	Solar heat exchanger	bar	6.0	6.0	6.0	6.0	6.0
Connections	Open vent	mm	22	22	22	28	28
	Cold feed	mm	15	15	15	15	15
	CH flow and return	mm	22	22	22	28	35
	HP flow and return	mm	22	22	28	35	35
	Wood burning stove flow and return	mm	28	28	28	28	28
	Solar circuit flow and return	mm	15	15	15	15	15
	Drain	in	R½"	R½"	R½"	R½"	R½"
Thermostat / sensor pockets	Heat pump control thermostat pockets 1 & 2	in	R½"	R½"	R½"	R½"	R½"
	Over heat thermostatic pocket	mm	8.5 ID	8.5 ID	8.5 ID	8.5 ID	8.5 ID
	Solar system sensor pocket	mm	8.5 ID	8.5 ID	8.5 ID	8.5 ID	8.5 ID
3kW, 230Vac, 50Hz immersion heaters - type 2			1	1	1	2	2
Hot water draw off volume at 35°C temperature rise <sup>(4)</sup>	Store charged at 55°C	litres	70	90	100	118	136
	Store charged at 60°C	litres	100	130	140	165	195
	Store charged at 65°C	litres	125	155	180	210	240
Notes							
(1) For checking compliance with the building regulation 2000 approved documents L1A and L1B using SAP procedure							
(2) For checking compliance with the building regulation 2000 approved documents L1A and L1B using 25 l/m <sup>2</sup> of net collector area							
(3) For checking compliance with the building regulation 2000 approved documents L1A and L1B							
(4) Hot water draw-off rate 15-17 l/min for 180/210, 17-20 l/min for 250/300 and 22-25 l/min for 450							

**Table 2b - Model selection guide**

	1-2	2-3	2-3	3-4	3-4
Bedrooms	1-2	2-3	2-3	3-4	3-4
Bathrooms	1	1	1	2	2
En-suite showers	0	1	2	1	2
Torrent MultiFuelStore HP Solar model	THP180 sol	THP210 sol	THP250 sol	THP300 sol	THP450 sol

# INSTALLATION

## General

- The Torrent MultiFuelStore HP is designed to be installed in an airing cupboard and the relevant minimum dimensions are given in table 1 'Technical data'. Installation and maintenance access is needed to the front and top of the appliance and this should be considered when positioning the appliance in a cupboard.

The floor of the cupboard needs to be level and even and capable of supporting the weight of the appliance when full (see table 1 for data on weights).

- All Torrent MultiFuelStore HP models are open vented and are suitable for use with any heat pump which does not require minimum pressure in the primary water circuit for operation.

The open vented primary system (thermal store, heat pump and central heating circuits) is filled via the feed and expansion cistern supplied with the unit. It is therefore important that the cistern is positioned at the highest point in the system. It is important to ensure that the minimum head for the heat pump and the system pump is as required by the heat pump manufacturer.

- It is envisaged that the feed and expansion cistern will be located in the same cupboard as the Torrent MultiFuelStore HP. However if it is necessary to locate the cistern in the roof space or on a higher floor then it must not be fitted more than 6 meters above the base of the Torrent MultiFuelStore HP appliance.

If the feed and expansion cistern is installed in a roof space (or unheated part of the dwelling), then any pipework and the feed and expansion cistern will need to be adequately insulated to protect against frost damage.

Please note: The feed and expansion tanks will not be large enough for all the stores/systems listed in the manual. It will be necessary to couple two together or replace with a larger tank in certain circumstances. We leave this to the installer to calculate because we do not know the capacities of multi fuel boilers etc.

- The heat pump should be sited as per manufacturers instructions and piped to the Torrent MultiFuelStore HP and the pipework should be sized for the flow rates recommended by the manufacturer and in any case should not be less than 22mm.
- Combined cold feed and vent pipe arrangements must not be used and no valves should be used in the safety open vent pipe which must be minimum of 22mm copper pipe or equivalent.
- The overflow/warning pipe shall have a continuous fall, be fitted to discharge clear of the building and be sited so that any overflow can be easily observed. It shall also be installed in a size and material suitable for use with heating feed and expansion cisterns in accordance with BS 5449 and should not have any other connections to it.
- The system will require at least two power supplies which needs to be 230V AC/50Hz/Single phase. One supply for the control circuit and one for the power supply to the heat pump. Both electrical supplies must be correctly earthed, polarised, correctly fused and in accordance with the latest addition of the IEE requirements for the electrical installation BS7671. Connections to both the control circuit and the heat pump (main power supply) must be made using a double pole linked isolators with a contact separation of 3mm in both poles and which are located within 1m of the respective appliance.
- All Torrent MultiFuelStore HP models are supplied with a 3kW (230V AC, 50Hz) immersion heater which incorporates an adjustable control thermostat and a non-resetable over-heat energy cut out set at about 85°C.

External wiring to the immersion heater must be in accordance with the relevant IEE Wiring regulations and the circuit must be protected by a suitable fuse and a double pole isolating switch.

# INSTALLATION

## **Torrent MultiFuelStore HP Models**

A typical wiring arrangement for a system in which the space heating is supplied from a Torrent MultiFuelStore HP (figures 7 and 9), is shown in figure 10 and a typical wiring arrangement for a system in which the space heating is supplied from a heat pump circuit (figures 6 and 8), is shown in figure 11.

In figure 10, the control of heat pump is shown with top and bottom thermostats to enhance the performance of the heat pump by decreasing the frequency of cycling. The heat pump is switched on when both top and bottom thermostats are calling for heat and is switched off when both thermostats stop calling for heat. A two channel programmer suitable for gravity hot water system should be used with this arrangement.

In figure 11, the generic wiring arrangement is shown with a 3-port diverter valve with hot water priority. If a 3-port flow share valve is used, then the controls should be wired to provide priority for hot water because the space heating and the hot water heating may be operating at different flow temperatures.

## **Torrent MultiFuelStore HP-Solar Models**

The heat pump and space heating system configurations and operation with the Torrent MultiFuelStore HP-solar models is the same as for standard models. The solar thermal system operates independent of the heat pump system. A typical generic solar system configuration is shown in figures 8, 9 and 12 for guidance only. The solar system and the associated controls should be planned and installed following manufacturers instructions.

All components in the solar primary system must be marked or identifiable in such a way that their design pressure and temperature can be readily determined.

A safety device i.e. pressure relief valve to control the risk of over-pressure in the system components should be fitted as per solar system manufacturers instructions. A termination from the pressure relief valve should minimise the risk of damage to persons or materials. Suitable locations are a high temperature receptacle, internal gully or else externally at ground level. High level termination from a wall or on a roof could cause injury to people or animals below if the valve were to release scalding water and steam.

The pipe leading to from the safety device to the collector should be rigid and non-deformable construction, without any possibility of restriction, distortion or closure by any other fitted component.

A typical wiring diagram for the solar thermal system for the Torrent MultiFuelStore HP-solar is shown in figure 11. It is advisable that an overheat thermostat is fitted to limit the store temperature exceeding 85°C from solar gains during stagnant conditions.

## **Wood Burning Stove**

Certain models of the Torrent MultiFuelStore HP and Torrent MultiFuelStore HP-solar have provision for connecting other alternative energy sources such as AGA or wood burning stove in conjunction with a heat leak radiator system. Although the thermal store is open vented and inherently safe, a heat leak system must be provided to prevent the possibility of boiling temperatures being reached. This is normally achieved by providing a suitable pipe thermostat on the alternative energy source flow pipe which is set to approximately 85-90°C and wired so that when this temperature is reached, the heating pump and/or zone valve will operate to allow excess heat to be dissipated through the heat leak circuit.

Alternative energy source should be installed and piped so that it conforms to the manufacturers instructions.

# INSTALLATION

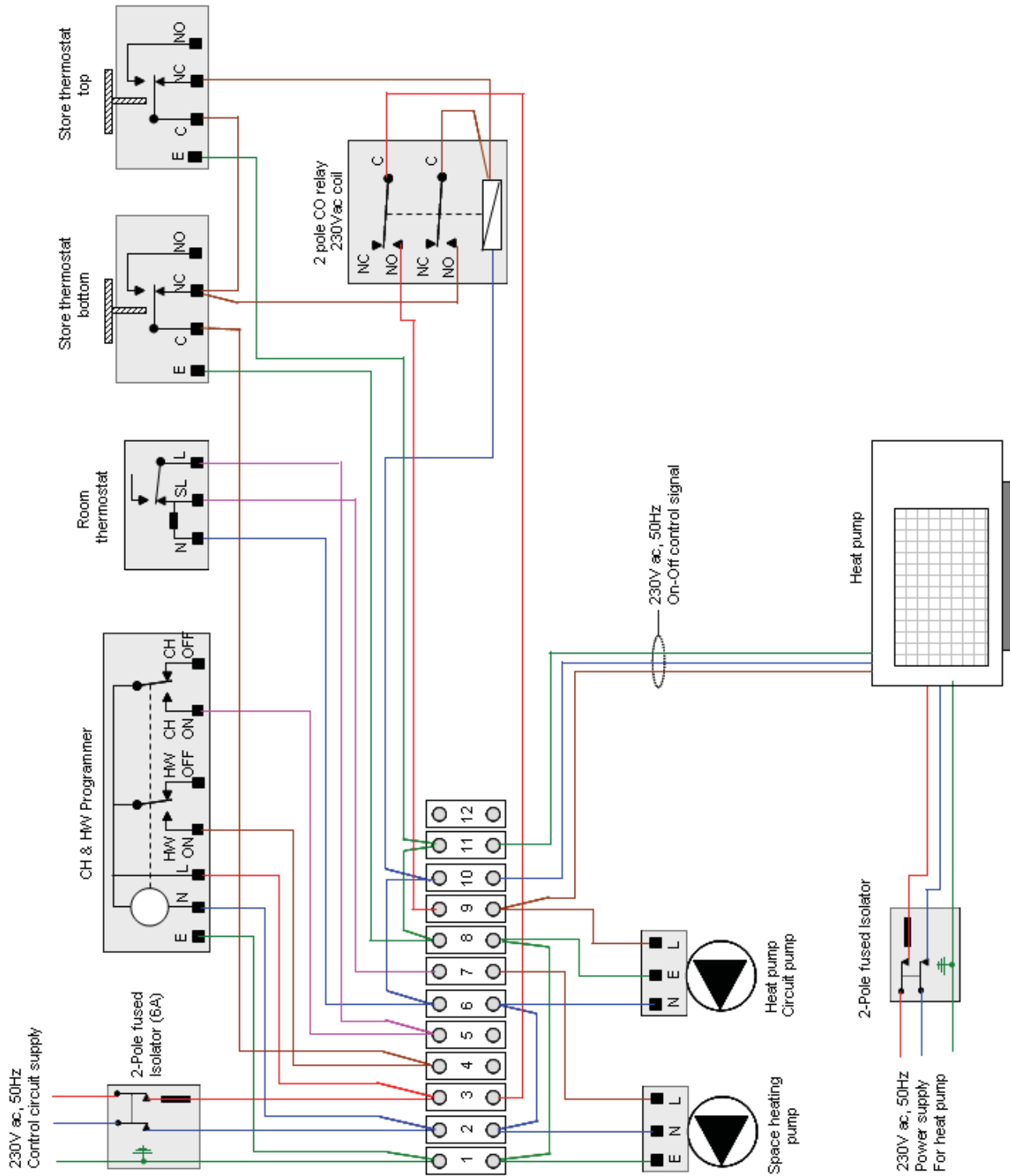

Figure 10 : Typical schematic wiring diagram for the Torrent MultiFuelStore HP and Torrent MultiFuelStore HP-solar with space heating supplied from thermal store as shown in figures 7 & 9.

# INSTALLATION

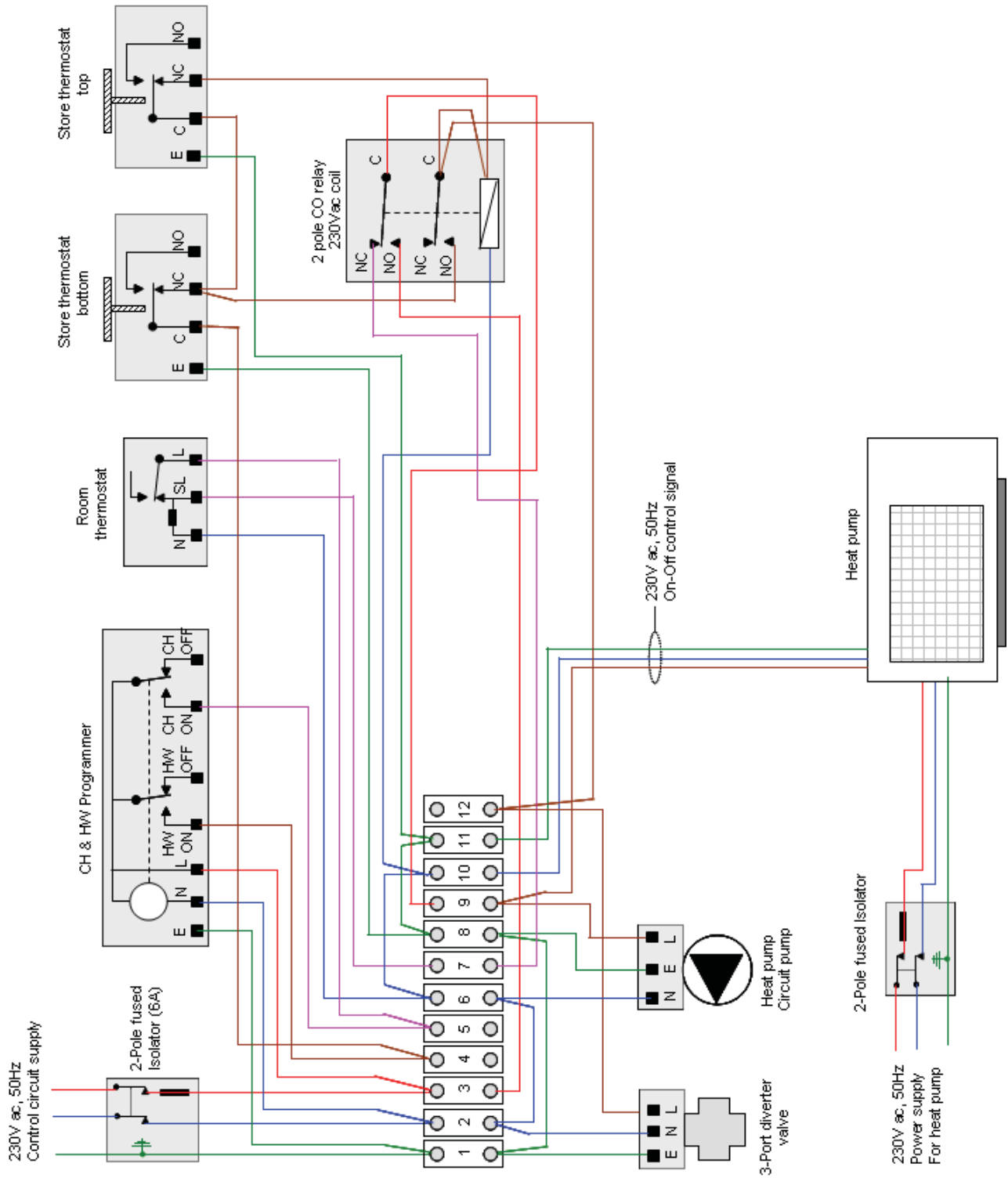

Figure 11 : Typical schematic wiring diagram for the Torrent MultiFuelStore HP and Torrent MultiFuelStore HP-solar with space heating supplied directly from the heat pump circuit as shown in figures 6 & 8.

# INSTALLATION

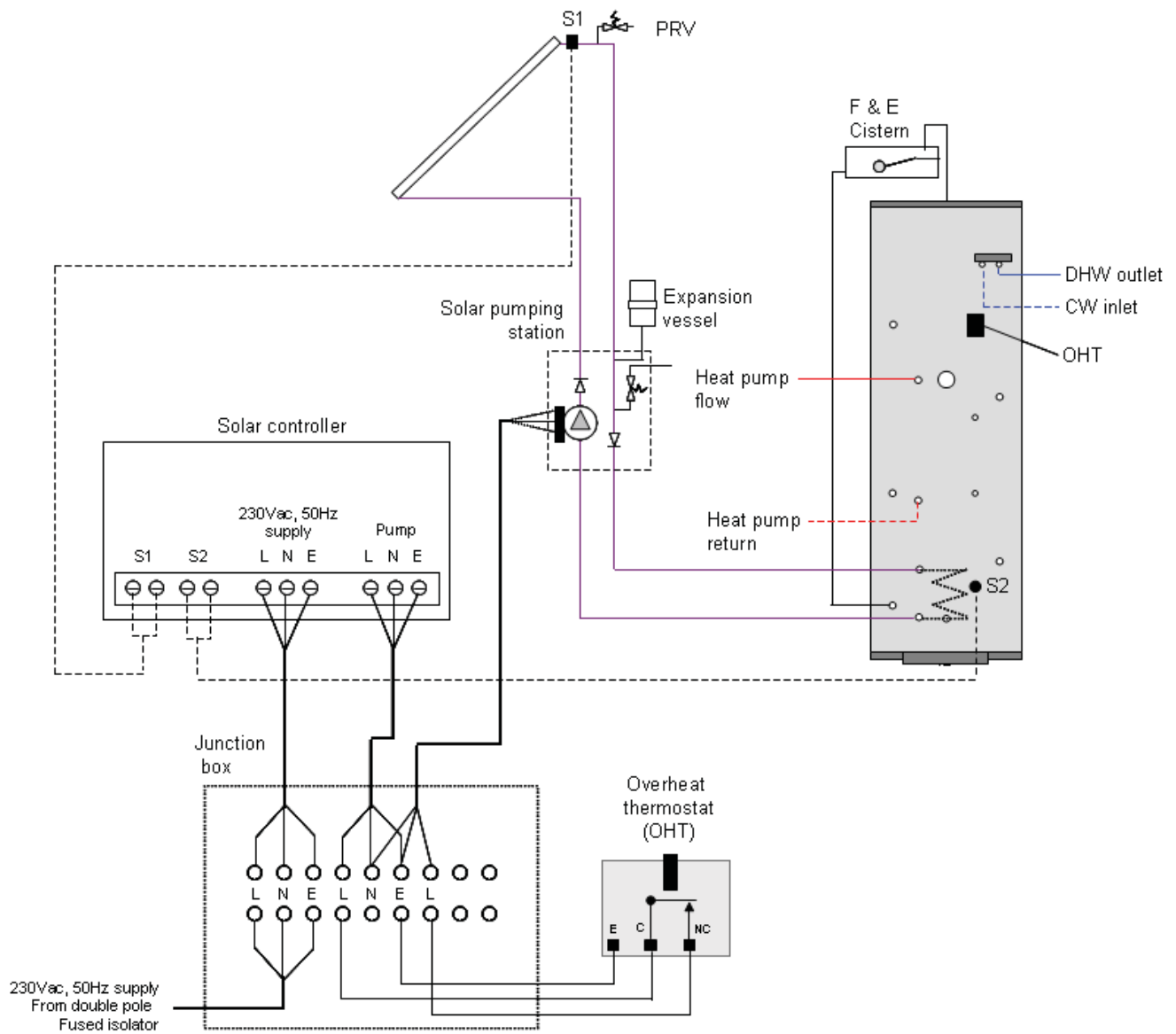

Figure 12 : Typical schematic wiring diagram and system configuration for the Torrent MultiFuelStore HP-solar.



# INSTALLATION

## Boost Immersion Heater

All Torrent MultiFuelStore HP models are fitted with a 3kW immersion heater so that the store can be heated to a temperature above the heat pump delivery temperature to increase the hot water performance of the unit if necessary. Because the TorrentHP is a primary thermal store it is **not** necessary to heat the store above 60°C for hygienic protection against growth of 'legionella'. This is because the domestic hot water is heated instantaneously via a heat exchanger and so there are no legionella problems associated with stored water.

This is of **great significance for the heat pump application** where the heat pump will not normally be able to raise stored water to above 60°C which is necessary to sterilise a cylinder.

By using the immersion element to boost the water temperature (**not** needed for legionella protection as described above), this will provide a greater volume of hot water from a given size of cylinder (see figures 3-5, page 5). However, the overall COP of the system will reduce and so to maximise the benefit of fitting a heat pump, minimal use should be made of the immersion heater.

The immersion heater should **not** be left permanently switched on as this will drastically reduce the contribution of heat pump to hot water heating and hence increase the running costs.

If the use of the immersion heater is necessary to meet the hot water requirements of a dwelling, then the preferred method of controlling it is described below.

## Control By Programmer

The operation of the boost immersion heater can be controlled by means of an independent time switch as shown schematically in figure 13. The on time settings on the immersion heater should be between 30 – 60 minutes later than the on times set for the hot water programmer channel.

For example if the hot water is programmed to come on between say 0600 – 0900 and 1700 – 2200 then the immersion heater timer setting should be 0640 – 0900 and 1740 – 2200. This will make maximum use of the heat pump allowing it to charge the store to the maximum potential temperature before any use of the immersion element.

Additional top and bottom thermostat pockets are provided in case a more sophisticated control system is required to be fitted.

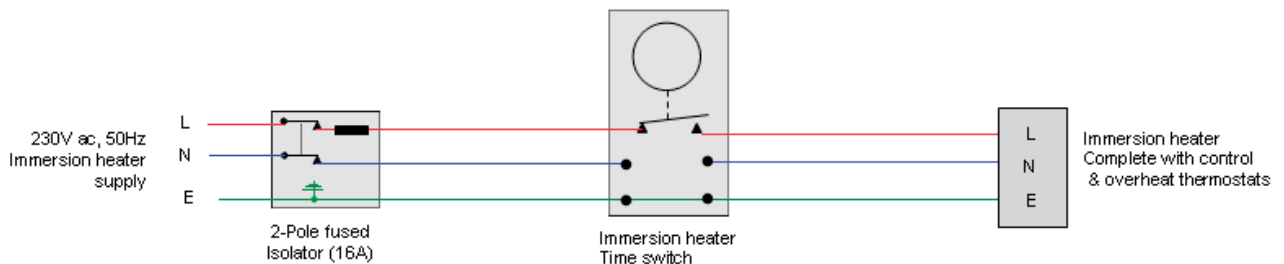

Figure 13 : Typical schematic wiring diagram for the boost immersion heater using programmable immersion heater timer.

# INSTALLATION

## Commissioning

Open the incoming stop valve and fill the domestic hot water system. Fill the whole of the primary heating system and the thermal store with potable water through the feed and expansion cistern.

Check the water level in the feed and expansion cistern and adjust the ball valve if necessary. Check the whole of the primary heating and domestic hot and cold distribution system, including the heat pump and the Torrent MultiFuelStore HP for leaks.

It is essential that all systems function properly for optimum performance and to achieve this:

- The primary system should be commissioned in accordance with good practice and generally in accordance with the requirements of BS 6798, BS 5449 and BS 7593. Full details of the requirements are given in PAS 33:1999 under section 10 Commissioning.
- The heat pump manufacturers instructions should be followed during the commissioning phase.
- If a solar thermal system is fitted it should be commissioned as per manufacturers instructions.
- When using either cleansing or corrosion inhibitor chemicals, the manufactures instructions must be followed.

When determining the quantities for cleanser required, the volume of the Torrent MultiFuelStore HP should be added to the water content of the primary system. Although the Torrent MultiFuelStore HP has no special water treatment requirements, the radiators and other parts of the circuit will require the application of a scale and corrosion inhibitor. The heat pump and the external connecting pipework will also require protection against freezing. For this reason, a combined antifreeze and inhibitor product such as Fernox Alpha 11 must be used.

If it is proposed to 'powerflush' the heating system we would recommend that the Torrent MultiFuelStore HP is isolated from the heating system being cleaned. Failure to do so could seriously damage the unit. If in doubt please contact our 'Technical Helpline'.

Ensure that the Torrent MultiFuelStore HP cistern is installed with the water level topped up to the level mark inside the feed and expansion cistern and the ballvalve is set correctly.

Ensure that the heat pump circuit and the space heating circuit are fitted and vented correctly.

Commission the heat pump as per the manufacturers instructions.

Check that the space heating system controls are functioning correctly ie. the programmer and room thermostat.

Switch off the space heating and allow the heat pump to heat the store only. During this heating cycle, adjust the store thermostats so that they switch on the heat pump just before it starts to cycle on its internal thermostat.

Check the store thermostat setting by drawing off the hot water and reheating the thermal store.

If necessary, use the immersion heater to boost the store temperature. If the immersion element is used to raise the temperature of the store, then a suitable control system should be used to ensure the immersion element does not operate until the heat pump has raised the store to the maximum temperature, or the overall efficiency of the system will be reduced. Check that the total hot water flow rate from the Torrent MultiFuelStore HP is a maximum of 15 - 17 litres/min. If necessary fit additional flow restrictors.

This product is covered by the Benchmark scheme and a commissioning/service record is included in this manual. This must be completed during commissioning and left with the product to meet the Warranty conditions offered by Gledhill.

## Important Do's and Don'ts

- DO -** Check the incoming mains water pressure. If it exceeds 3.5 bar at any point in a 24 hour cycle then a pressure limiting valve set at 3.5 bar should be fitted where the cold supply enters the property.
- DO -** Check that all connections are in accordance with the labelling on the thermal store.
- DO -** Fill the cistern manually or adjust the ballvalve so that the water in the F & E cistern is set to the correct level.
- DO -** Restrict the ballvalve fill rate when full so that the overflow pipe can cope with the fill rate in the event of a ballvalve failure.
- DO -** Make sure there is adequate clearance above the F & E cistern to service the valve.
- DO -** Ensure that the water level in the expansion cistern is at least 250mm above the highest point on the radiator circuit and satisfies the boiler head required.
- DO -** Insulate any exposed pipework in the Torrent cupboard.
- DO -** Plumb the overflow warning pipe in 20mm minimum internal diameter tubing to discharge in a conspicuous external position, using high temperature uPVC or copper.
- DO -** Check the pump setting. This should be set to give a temperature difference recommended by the manufacturer of the heat pump.
- DON'T -** Use a combined feed and vent on Torrent indirect installations.

# SERVICING

	Description	Stock Code	Gas Council Part Number
1	Ballvalve Float	FT429	370 506
2	Mixing Valve - Brawa	XC007	385 872
3	Immersion Heater 3kW	XB078	E39 184
4	Control Thermostat	XC010	

# APPENDIX

## Water Savings

### Water Related Costs Can Be Reduced By Good Plumbing Practice

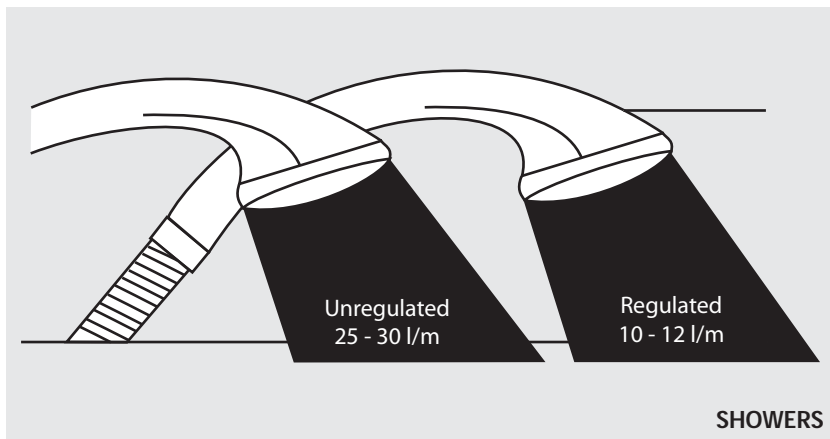
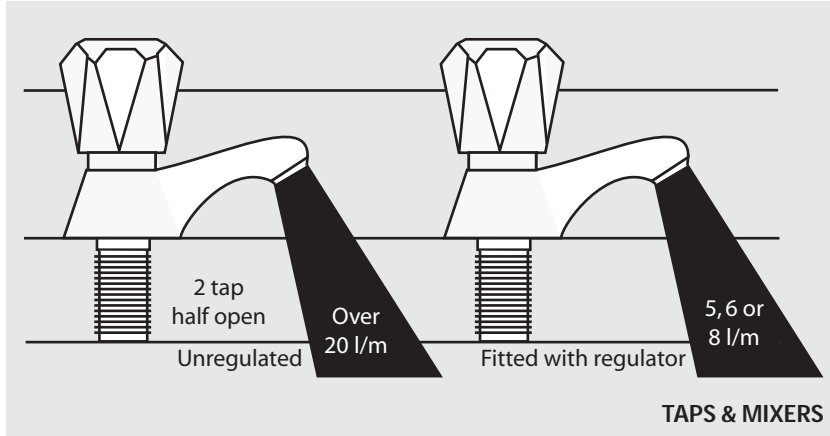

Vast quantities of water are needlessly run off to waste due to Taps, Mixers and Showers discharging flow rates far in excess of the rates required for them to perform their duties.

The contrasting flow rates shown on this leaflet clearly illustrate the savings that can be made whilst still providing a good performance.

British made Aquaflow Regulators provide constant flow rates by automatically compensating for supply pressure changes between 1 bar & 10 bars.

To facilitate installation into the wide range of plumbing equipment which is encountered in the U.K, Four Fixing Options are available:-

#### Options For Showers

1. MXF "DW" Range - For fitting behind Fixed Shower Heads or onto Flexible Hoses for Handshowers (preferably onto the inlet end when lightweight hoses are used).
2. Compression Fitting Range. "In Line" regulators as in Option 4 for Taps & Mixers.

Information by courtesy of  
**AQUAFLOW REGULATORS LTD**

Haywood House, 40 New Road, Stourbridge, West Midlands DY8 1PA  
TELEPHONE (01384) 442611 FAX: (01384) 442612

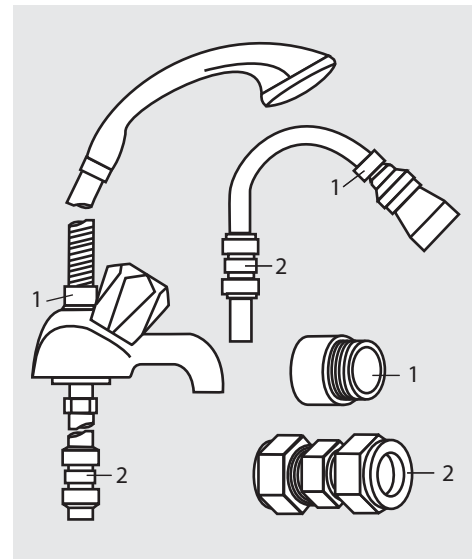

#### 4 Fixing Options For Taps & Mixers

1. MK Range - Combined Regulators & Aerator for screwing onto Taps & Mixers with internal or external threads on their noses. Anti Vandal models also available.
2. MR05-T Range - Internal Regulators. Push-fit into Tap or Mixer seats. Produced in three sizes - 12.5mm (BS1010), 12mm & 10mm, Flangeless models also available for Taps with Low Lift washers.
3. MXF Standard Range - Screw on tail models for Taps & Mixers. Fix onto the tails before fitting the tap connectors. Available in 3/8", 1/2", 3/4" and 1" BSP.
4. Compression Fitting Range - "In Line" regulators housed in 15mm & 22mm CXC Couplers & Isolating Valves. "UKWFBS" listed by the Water Research Centre. Isolation valves available for slotted screwdriver operation or with coloured plastic handles. Now available also in plastic bodied push-fit couplers & valves.

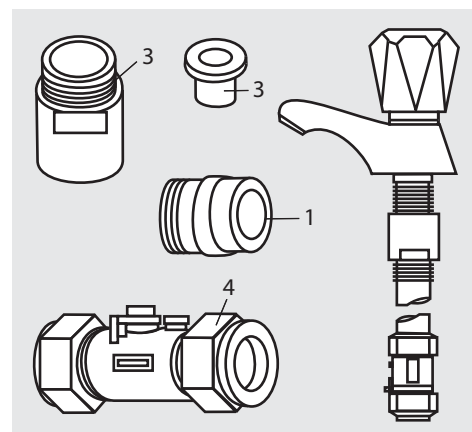



## Product data

### PROTECTOR ALPHI-11

- Protects against corrosion and limescale
- Maintains efficiency so extending system life
- Prevents bacterial contamination
- Compatible with all metals and materials commonly used in heating systems
- Non-toxic, environmentally friendly
- Combined antifreeze and protector
- Protects heating, chilled water and solar systems

#### Product Uses

Fernox Protector Alphi-11 is a combined antifreeze and inhibitor, which gives long term protection of domestic central heating systems against internal corrosion and limescale formation. It prevents corrosion of all metals found in these systems, i.e. ferrous metals, copper and copper alloys and aluminium. It is especially recommended for use in solar systems. Fernox Protector Alphi-11 is compatible with all metals and materials commonly used in central heating systems.

For continued protection we recommend Protector levels are checked regularly (annually). The concentration of the product can be easily measured on site using a Fernox 'One Drop' Protector test kit.

#### Physical Properties

Fernox Protector Alphi-11 contains mono-propylene glycol.

Colour:	Colourless
Odour:	Mild
Form:	Clear liquid
pH (conc)	5.7 – 6.1
pH (soln 25%):	7.0 – 7.5
SG:	1.04 at 20°C

#### Application and Dosage

The minimum recommended "in-use" concentration of the product is 25% in order to ensure adequate corrosion protection. This concentration will protect down to -11°C. A concentration of 40% will protect down to -22°C. Alphi-11 Protector can be introduced via the feed and expansion tank or other suitable point of application, e.g. radiator, using a Fernox Injector. Introduce into the system after having drained a quantity of water at least equal to the amount of Alphi-11 to be added. Engage the circulating pump and have the system online for a few hours in order to achieve an even distribution.

Concentration	25%	30%	35%	40%
Protection	-11°C	-15°C	-18°C	-22°C

In single feed indirect cylinders, e.g. "Primatic" or similar, potable water chemicals must be used.

We recommend untreated systems are thoroughly cleansed and flushed, in accordance with BS7593 and Benchmark, using Fernox Cleaner F3 before treating with Fernox Alphi-11 Protector as existing debris can damage the installation.



Cookson Electronics, Forsyth Road, Sheerwater, Woking, Surrey, GU21 5RZ  
 Tel: +44 (0) 1483 793200 Fax: +44 (0) 1483 793201 Technical: +44 (0) 870 870 0362  
 email: sales@fernox.com · www.fernox.com

©Cookson Electronics is a trading name of Alpha Pty Ltd, a Cookson Group Company. Registered in London No. 2841115. VAT No. GB 258 1786 00





# SERVICE RECORD

It is recommended that your hot water system is serviced regularly and that the appropriate Service Record is completed.

## Service Provider

Before completing the appropriate Service Record below, please ensure you have carried out the service as described in the manufacturer's instructions.

**SERVICE 1** Date \_\_\_\_\_  
Engineer Name \_\_\_\_\_  
Company Name \_\_\_\_\_  
Telephone Number \_\_\_\_\_  
Comments \_\_\_\_\_  
\_\_\_\_\_  
\_\_\_\_\_  
Signature \_\_\_\_\_

**SERVICE 2** Date \_\_\_\_\_  
Engineer Name \_\_\_\_\_  
Company Name \_\_\_\_\_  
Telephone Number \_\_\_\_\_  
Comments \_\_\_\_\_  
\_\_\_\_\_  
\_\_\_\_\_  
Signature \_\_\_\_\_

**SERVICE 3** Date \_\_\_\_\_  
Engineer Name \_\_\_\_\_  
Company Name \_\_\_\_\_  
Telephone Number \_\_\_\_\_  
Comments \_\_\_\_\_  
\_\_\_\_\_  
\_\_\_\_\_  
Signature \_\_\_\_\_

**SERVICE 4** Date \_\_\_\_\_  
Engineer Name \_\_\_\_\_  
Company Name \_\_\_\_\_  
Telephone Number \_\_\_\_\_  
Comments \_\_\_\_\_  
\_\_\_\_\_  
\_\_\_\_\_  
Signature \_\_\_\_\_

**SERVICE 5** Date \_\_\_\_\_  
Engineer Name \_\_\_\_\_  
Company Name \_\_\_\_\_  
Telephone Number \_\_\_\_\_  
Comments \_\_\_\_\_  
\_\_\_\_\_  
\_\_\_\_\_  
Signature \_\_\_\_\_

**SERVICE 6** Date \_\_\_\_\_  
Engineer Name \_\_\_\_\_  
Company Name \_\_\_\_\_  
Telephone Number \_\_\_\_\_  
Comments \_\_\_\_\_  
\_\_\_\_\_  
\_\_\_\_\_  
Signature \_\_\_\_\_

**SERVICE 7** Date \_\_\_\_\_  
Engineer Name \_\_\_\_\_  
Company Name \_\_\_\_\_  
Telephone Number \_\_\_\_\_  
Comments \_\_\_\_\_  
\_\_\_\_\_  
\_\_\_\_\_  
Signature \_\_\_\_\_

**SERVICE 8** Date \_\_\_\_\_  
Engineer Name \_\_\_\_\_  
Company Name \_\_\_\_\_  
Telephone Number \_\_\_\_\_  
Comments \_\_\_\_\_  
\_\_\_\_\_  
\_\_\_\_\_  
Signature \_\_\_\_\_

**SERVICE 9** Date \_\_\_\_\_  
Engineer Name \_\_\_\_\_  
Company Name \_\_\_\_\_  
Telephone Number \_\_\_\_\_  
Comments \_\_\_\_\_  
\_\_\_\_\_  
\_\_\_\_\_  
Signature \_\_\_\_\_

**SERVICE 10** Date \_\_\_\_\_  
Engineer Name \_\_\_\_\_  
Company Name \_\_\_\_\_  
Telephone Number \_\_\_\_\_  
Comments \_\_\_\_\_  
\_\_\_\_\_  
\_\_\_\_\_  
Signature \_\_\_\_\_







# Gledhill (Building Products) Ltd

AMD.OCTOBER 2011  
CONDITIONS OF SALE & GUARANTEE TERMS

1. Gledhill (Building Products) Ltd ("We" or "Gledhills") only do business upon the Conditions which appear below and no other. Unless we so agree in writing these Conditions shall apply in full to any supply of goods by us to the exclusion of any Conditions or terms sought to be imposed by any purchaser. These Conditions of Sale and Warranty Terms override those which are contained on the Invoice Forms and all Sales are now subject to these Conditions of Sale and Warranty terms only.

## 2. PRICE

Once an order or call off has been accepted the price will be held for three months **but if delivery is extended beyond that period at the customer's request, then we reserve the right to amend the price when necessary.** The company reviews its pricing annually to adjust for changes in our cost base. We reserve the right to alter prices at any time for severe movements in raw materials (mainly copper and steel). If there is to be a change we will give customers at least four weeks notice but anything delivered after that date will be at the revised price. An order may not be cancelled or varied after acceptance without the written consent of the company. Such cancellation or variation shall be subject to such reasonable charges as may be appropriate.

## 3. SPECIFICATION

The goods are supplied in accordance with the Specifications (if any) submitted to the Purchaser and any additions and alterations shall be the subject of an extra charge. Any goods not so specified shall be in accordance with our printed literature or the literature of any of our component suppliers (subject to any modifications made since publication). If we adopt any changes in construction or design of the goods, or in the specification printed in our literature, the Purchaser shall accept the goods so changed in fulfilment of the order.

## 4. PAYMENT

The buyer shall make payment in full within thirty days from the end of the month in which the invoice is dated. If we receive payment in full on or before the due date we will allow an appropriate settlement discount except where we have quoted a special net price. If payment is not received in full on or before the due date we shall be entitled in addition to the invoice price to:

- (i) payment of a sum equal to any increase in the copper price supplement applicable to the particular goods sold between the date of receipt of order and the date of receipt of payment in full; and
- (ii) interest on any part of the invoice price unpaid after the due date at the rate of 3% per annum over the base rate for the time being of HSBC Bank plc.

## 5. TIME

We give estimates of delivery dates in good faith and time of delivery is not nor shall be made of the essence of any contract nor shall we be liable for any loss or damage occasioned by delay in delivery.

## 6. DELIVERY

We deliver free normally by our own vehicles within 25 miles of any of our manufacturing depots. Delivery to any place more than 25 miles from one of our manufacturing depots may be subject to our quoted delivery charges. We reserve the right to make delivery of goods contained in one order by more than one consignment and at different times. Where a period is agreed for delivery and such period is not extended by our Agreement, the Purchaser shall take delivery within that period. If the Purchaser fails to take delivery, we shall be entitled at the Purchaser's risk and expense to store the goods at the Purchaser's premises or elsewhere and to demand payment as if they had been despatched. Off loading at point of delivery shall be the responsibility of and be undertaken by the Purchaser.

## 7. SHORTAGES OR DAMAGE

Goods must be inspected before signature of delivery note and any damage, shortage or discrepancy noted on the delivery note and the goods returned on the same vehicle. The buyer must also give us immediate written notice of the damage, shortage or discrepancy so that we may prompt investigation.

## 8. RETURN OF GOODS

Goods may not be returned to the Company except by prior written permission of an authorised officer of the Company and such return shall be subject to payment by the Purchaser of handling and re-stocking charges, transport and all other costs incurred by the Company.

## 9. COMPANY LIABILITY AND GUARANTEE

9.1. Subject to the terms of these Conditions of Sale and Guarantee Terms Gledhills provide Guarantees in respect of specific products as set out in this clause.

9.2. Each Guarantee is strictly conditional upon the following:-

9.2.1. Complaints must be given to us immediately, before any action is taken, as responsibility cannot be accepted if repairs or renewals are attempted on site without our written approval.

9.2.2. The unit has been installed in accordance with our installation and service instructions and all relevant codes of practice and regulations in force at the time of installation.

9.2.3. All necessary inlet controls and safety valves have been fitted correctly.

9.2.4. The unit has only been used for the storage of potable water supplied from the public mains.

9.2.5. Where appropriate the unit has been regularly maintained as detailed in the installation and service instructions

9.2.6. Defects caused by corrosion or scale deposits are not covered by any Guarantee.

9.2.7. Where we agree to rectify any defect we reserve the right to undertake the work on our own premises.

9.2.8. We will not accept any labour charges associated with replacing the unit or parts for any of the following products listed.

9.3. Guarantees are provided in respect of specified goods supplied by Gledhills as follows:-

### (a) Domestic and Commercial Open Vented Cylinders and Tanks.

The storage vessel is guaranteed for ten years and if it proves to be defective either in materials or workmanship, we will either repair or supply replacement at our option with the closest substitute in the case of any obsolete product to any address in Great Britain.

(i) free of all charge during the first year after delivery by us.

(ii) thereafter at a charge of one-tenth of the then current list price and any copper price supplement and delivery charge during the second year after delivery by us and increasing by a further one-tenth on the second and subsequent anniversary of delivery by us.

### (b) Domestic Mains Fed Products [Primary Stores]

The storage vessel is guaranteed for five years and if it or any integral pipework as part of the storage vessel assembly proves to be defective either in materials or workmanship, we reserve the right to either repair or supply replacements or the closest possible substitute in the case of any obsolete product and will collect and deliver to any address in England, Wales and Scotland (excluding all Scottish Islands).

(i) free of all charge during the first year after delivery by us.

(ii) thereafter at a charge of one-fifth of the then current list price or any copper price supplement and delivery charge during the second year after delivery by us increasing by a further one-fifth on the second and subsequent anniversary of delivery by us.

### (c) Stainless Steel Unvented Cylinders

Gledhill guarantee the components including controls, valves and electrical parts for two years from the date of purchase. IT SHOULD BE NOTED THAT THE FACTORY FITTED TEMPERATURE AND PRESSURE RELIEF VALVE MUST NOT BE REMOVED OR ALTERED IN ANY WAY OR THE GUARANTEE WILL NOT BE VALID. GLEDHILL WILL NOT BE RESPONSIBLE FOR ANY CONSEQUENTIAL LOSS OR DAMAGE HOWEVER IT IS CAUSED.

The guarantee for the stainless steel vessel is for twenty five years if the original unit is returned to us **AND PROVIDED THAT:**

- (i) It has not been modified, other than by Gledhill.
- (ii) It has not been subjected to wrong or improper use or left uncared for.
- (iii) It has only been used for the storage of potable water, max 200mg/litre chloride.
- (iv) It has not been subjected to frost damage.
- (v) The benchmark service record is completed after each annual service.
- (vi) The unit has been serviced annually.
- (vii) Any disinfection has been carried out strictly in accordance with BS6700.

If the stainless steel vessel proves to be defective either in materials or workmanship we reserve the right to either repair or supply replacements or the closest possible substitute in the case of any obsolete product and will collect and deliver to any address in England, Scotland and Wales (excluding all islands):

- (i) free of charge during the first year after delivery by us.
- (ii) thereafter at a charge of one twenty fifth of the then current list price during the second year after delivery by us and increasing by a further one twenty fifth on the second and subsequent anniversary of delivery by us.

### ACTION IN THE EVENT OF FAILURE

If the stainless steel cylinder develops a leak we will ask for a deposit against the supply of a new one. This will be refunded if the failure is within the terms of the warranty when it has been examined by us.

### **Please note:**

- Installation must have been carried out by a licensed specialized company (heating contractor or plumber) following the version of installation instructions in force.
- Gledhill or its representative was given the opportunity to check complaints on site immediately after any defect occurred.
- Confirmation exists that the system was commissioned properly and that the system was checked and maintenance was performed annually by a specialised company licensed for this purpose.

### (d) Components of our products other than Storage Vessels and Integral Pipework.

We will either extend to the purchaser the same terms of warranty as we are given by the manufacturer of the component or if the manufacturer does not give any warranty, replace free of charge any component which becomes defective within two years after the date of the delivery by us and is returned to us at the purchaser's expense but we shall not meet the cost of removal or shipping or return of the component or any other cost charges or damages incurred by the purchaser.

9.4.

9.4.1. In respect of goods supplied by us and in respect of any installation work carried out by or on our behalf, our entire liability and the purchaser's sole remedies (subject to the Guarantees) shall be as follows:-

- (a) We accept liability for death or personal injury to the extent that it results from our negligence or that of our employees
- (b) Subject to the other provisions of this clause 9 we accept liability for direct physical damage to tangible property to the extent that such damage is caused by our negligence or that of our employees, agents or subcontractors.

- (c) Our total liability to the purchaser over and above any liability to replace under the Guarantees (whether in contract or in tort including negligence) in respect of any one cause of loss or damage claimed to result from any breach of our obligations hereunder, shall be limited to actual money damages which shall not exceed £20,000 provided that such monetary limit shall not apply to any liability on the part of ourselves referred to in paragraph (a) above
- (d) Except as provided in paragraph (a) above but otherwise notwithstanding any provision herein contained in no event shall we be liable for the following loss or damage howsoever caused and even if foreseeable by us or in our contemplation:-
  - (i) economic loss which shall include loss of profits, business revenue, goodwill or anticipated savings
  - (ii) damages in respect of special indirect or consequential loss or damage (other than death, personal injury and damage to tangible property)
  - (iii) any claim made against the purchaser by any other party (save as expressly provided in paragraph (b) above)
- (e) Except in respect of our liability referred to in paragraph (a) above no claim may be made or action brought (whether in contract or in tort including negligence) by the purchaser in respect of any goods supplied by us more than one year after the date of the invoice for the relevant goods.
- (f) Without prejudice to any other term we shall not be liable for any water damage caused directly or indirectly as a result of any leak or other defect in the goods. We cannot control the conditions of use of the goods or the time or manner or location in which they will be installed and the purchaser agrees to be fully responsible for testing and checking all works which include the goods at all relevant times (up to, including and after commissioning) and for taking all necessary steps to identify any leaks and prevent any damage being caused thereby.
- (g) Nothing in these Conditions shall confer on the purchaser any rights or remedies to which the purchaser would not otherwise be legally entitled

#### 10. LOSS OR INJURY

Notwithstanding any other provision contained herein the purchaser's hereby agree to fully indemnify us against any damages losses costs claims or expenses incurred by us in respect of any claim brought against us by any third party for:-

- (a) any loss injury or damage wholly or partly caused by any goods supplied by us or their use.
- (b) any loss injury or damage wholly or partly caused by the defective installation or substandard workmanship or materials used in the installation of any goods supplied by us.
- (c) any loss injury or damage in any way connected with the performance of this contract.
- (d) any loss resulting from any failure by the purchaser to comply with its obligations under these terms as to install and/or check works correctly.

**PROVIDED** that this paragraph will not require the purchaser to indemnify us against any liability for our own acts of negligence or those of our employees agents or sub-contractors

**FURTHER** in the case of goods supplied by us which are re-sold and installed by a third party by the purchaser it will be the sole responsibility of the purchaser to test the goods immediately after their installation to ensure that inter alia they are correctly installed and in proper working order free from leaks and are not likely to cause any loss injury or damage to any person or property.

#### 11. VARIATION OF WARRANTY AND EXCLUSION

Should our warranty and exclusion be unacceptable we are prepared to negotiate for variation in their terms but only on the basis of an increase in the price to allow for any additional liability or risk which may result from the variation. Purchasers are advised to insure against any risk or liability which they may incur and which is not covered by our warranty.

#### 12. ADVICE

Any advice or assistance given by the Company is provided without charge and is in good faith without undertaking, representation or warranty, and we will not accept any liability, whether consequential or compensatory, for advice or assistance given.

#### 13. RISK AND RETENTION OF TITLE

- (a) goods supplied by us shall be at the Purchaser's risk immediately upon delivery to the Purchaser or into custody on the Purchaser's behalf or to the Purchaser's Order. The Purchaser shall effect adequate insurance of the goods against all risks to the full invoice value of the goods, such insurance to be effective from the time of delivery until property in the goods shall pass to the Purchaser as hereinafter provided.
- (b) property in the goods supplied hereunder will pass to the Purchaser when full payment has been made by the Purchaser to us for :-
  - (i) the goods of the subject of this contract.
  - (ii) all other goods the subject to of any other contract between the Purchaser and us which, at the time of payment of the full price of the goods sold under this contract, have been delivered to the Purchaser but not paid for in full.
- (c) until property in the goods supplied hereunder passes to the Purchaser in accordance with paragraph (2) above.
  - (i) the Purchaser shall hold the goods in a fiduciary capacity for us and shall store the same separately from any other goods in the Purchaser's possession and in a manner which enables them to be identified as our goods.
  - (ii) the Purchaser shall immediately return the goods to us should our authorised representative so request. All the necessary incidents associated with a fiduciary relationship shall apply.
- (d) the Purchaser's right to possess the goods shall cease forthwith upon the happening of any of the following events, namely :-
  - (i) if the Purchaser fails to make payment in full for the goods within the time stipulated in clause 4 hereof.
  - (ii) if the Purchaser, not being a company, commits any act of bankruptcy, makes a proposal to his or her creditors for a compromise or does anything which would entitle a petition for a Bankruptcy Order to be presented.
  - (iii) if the Purchaser, being a company, does anything or fails to do anything which would entitle an administrator or an administrative receiver or a receiver to take possession of any assets or which would entitle any person to present a petition for winding up or to apply for an administration order.
- (e) the Purchaser hereby grants to us an irrevocable licence to enter at any time any vehicle or premises owned or occupied by the Purchaser or in the possession of the Purchaser for the purposes of repossessing and recovering any such goods the property in which has remained in us under paragraph (2) above. We shall not be responsible for and the Purchaser will indemnify us against liability in respect of damage caused to any vehicle or premises in such repossession and removal being damaged which it was not reasonably practicable to avoid.
- (f) notwithstanding paragraph (3) hereof and subject to paragraph (7) hereof, the Purchaser shall be permitted to

sell the goods to third parties in the normal course of business. In this respect the Purchaser shall act in the capacity of our commission agent and the proceeds of such sale :-

- (i) shall be held in trust for us in a manner which enables such proceeds to be identified as such, and :
    - (ii) shall not be mixed with other monies nor paid into an overdrawn bank account.
- We, as principal, shall remunerate the Purchaser as commission agent a commission depending upon the surplus which the Purchaser can obtain over and above the sum, stipulated in this contract of supply which will satisfy us.
- (g) in the event that the Purchaser shall sell any of the goods pursuant to clause (6) hereof, the Purchaser shall forthwith inform us in writing of such sale and of the identity and address of the third party to whom the goods have been sold.
  - (h) if, before property in the goods passes to the Purchaser under paragraph (2) above the goods are or become affixed to any land or building owned by the Purchaser it is hereby agreed and declared that such affixation shall not have the effect of passing property in the goods to the Purchaser. Furthermore if, before property in the goods shall pass to the Purchaser under paragraph (2) hereof, the goods are or become affixed to any land or building (whether or not owned by the Purchaser), the Purchaser shall:-
    - (i) ensure that the goods are capable of being removed without material injury to such land or building.
    - (ii) take all necessary steps to prevent title to the goods from passing to the landlord of such land or building.
    - (iii) forthwith inform us in writing of such affixation and of the address of the land or building concerned.

The Purchaser warrants to repair and make good any damage caused by the affixation of the goods to or their removal from any land or building and to indemnify us against all loss damage or liability we may incur or sustain as a result of affixation or removal.

- (i) in the event that, before property in the goods has passed to the Purchaser under paragraph (2) hereof, the goods or any of them are lost, stolen, damaged or destroyed :-
  - (ii) the Purchaser shall forthwith inform us in writing of the fact and circumstances of such loss, theft, damage or destruction.
  - (iii) the Purchaser shall assign to us the benefit of any insurance claim in respect of the goods so lost, stolen, damaged or destroyed.

#### 14. NON-PAYMENT

If the Purchaser shall fail to make full payment for the goods supplied hereunder within the time stipulated in clause 4 hereof or be in default of payment for any other reason then, without prejudice to any of our other rights hereunder, we shall be entitled to stop all deliveries of goods and materials to the Purchaser, including deliveries or further deliveries of goods under this contract. In addition we shall be entitled to terminate all outstanding orders.

#### 15. VALUE ADDED TAX

All prices quoted are exclusive of Value Added Tax which will be charged at the rate ruling at the date of despatch of invoice.

#### 16. TRADE SALES ONLY

We are only prepared to deal with those who are not consumers within the terms of the Unfair Contract Terms Act 1977, the Sale of Goods Act 1979 and the Supply of Goods and Services Act 1982. Accordingly any person who purchases from us shall be deemed to have represented that he is not a consumer by so purchasing.

#### 17. JURISDICTION

The agreement is subject to English law for products delivered in England and Scottish law for products delivered in Scotland and any dispute hereunder shall be settled in accordance therewith dependent upon the location.

#### 18. PRODUCT DEVELOPMENT

Gledhill have a policy of continuous product development and may introduce product modifications from time to time.

# Providing peace of mind

On expiry of your initial warranty period, Gledhill Response Limited would be pleased to provide further customer support with a range of services including:

Low cost annual repair and maintenance contracts direct from Gledhill

Annual servicing and safety checks

Expert response to 'out of warranty' breakdowns at fixed charges

Please ring 08445 679898 or visit [www.gledhill.net](http://www.gledhill.net) for further details



## Gledhill Building Products Limited

Sycamore Estate, Squires Gate, Blackpool FY4 3RL Tel: 01253 474550 Fax: 01253 474551 [sales@gledhill.net](mailto:sales@gledhill.net)

Gledhill Building Products produce cylinders for use with a wide range of heat sources including;

**Gas and oil boilers**  
**Ground source heat pumps**

**Electricity**  
**Solar energy**

**Air source heat pumps**  
**Wood burning stoves**

For further information of Gledhill products can be found on the internet at [www.gledhill.net](http://www.gledhill.net)



Due to a programme of continuous improvement Gledhill Building Products reserve the right to modify products without prior notice. It is advisable to check the product technical detail by using the latest design and installation manuals available from our technical support team or on our website.