

# *Torrent Range*



A total hot water and heating thermal store that can also make the most of renewable energy

## Design, Installation & Servicing Instructions

All models comply with the Hot Water Association  
specification for thermal stores

Please leave these instructions adjacent  
to the appliance





### Building Regulations and Benchmark Commissioning

The Building Regulations (England & Wales) require that the installation of a heating appliance be notified to the relevant Local Authority Building Control Department. From 1st April 2005 this can be achieved via a Competent Person Self Certification Scheme as an option to notifying the Local Authority directly. Similar arrangements will follow for Scotland and will apply in Northern Ireland from 1st January 06.

CORGI operates a Self Certification Scheme for gas heating appliances.

These arrangements represent a change from the situation whereby compliance with the Building Regulations was accepted if the Benchmark Logbook was completed and this was then left on site with the customer.

With the introduction of a self certification scheme, the Benchmark Logbook is being replaced by a similar document in the form of a commissioning check list and a service interval record is included with all gas appliance manuals. However, the relevant Benchmark Logbook is still being included with all Thermal Storage products and unvented cylinders.

Gledhill fully supports the Benchmark aims to improve the standards of installation and commissioning of central heating systems in the UK and to encourage the regular servicing of all central heating systems to ensure safety and efficiency.

Building Regulations require that the heating installation should comply with the manufacturer's instructions. It is therefore important that the commissioning check list is completed by the competent installer. This check list only applies to installations in dwellings or some related structures.

**A WRAS listed product developed by Gledhill Building Products in the 1980's in conjunction with British Gas plc.**

**British patent nos. 1358166, 2136099**

**British patent applications published under nos. 2136099, 2153503, 2153504, 8516025**

**This product is manufactured under an ISO 9001:2008 Quality System audited by BSI.**

**Gledhill's first priority is to give a high quality service to our customers.**

**Quality is built into every Gledhill product and we hope you get satisfactory service from Gledhill.**

**If not please let us know.**

These instructions should be read in conjunction with the Installation and Servicing Instructions issued by the manufacturers of the heat source e.g. the boiler used.

Any water distribution and central heating installation must comply with the relevant recommendations of the current version of the Regulations and British Standards listed below:-

Gas Safety Regulations  
Building Regulations  
I.E.E. Requirements for Electrical Installations  
Water Regulations

#### **British Standards**

BS6798, BS5449, BS5546, BS5440:1, BS5440:2, CP331:3, BS6700, BS5258, BS7593:1993 and BS7671.

It must be installed by a competent person as stated in the Gas Safety Regulations. Manufacturers notes must NOT be taken as over-riding statutory obligations.

Torrent is not covered by Section G3 of the current Building Regulations but the installation is notifiable to building control unless it is carried out under an approved competent person self-certification scheme.

Although the secondary supply (domestic) is at mains pressure, it is not necessary to fit an expansion chamber, pressure or temperature relief valve, the plumbing should allow any unusual build up of pressure to be relieved at the ball valve.

The information in this manual is provided to assist generally in the selection of equipment. The responsibility for the selection and specification of the equipment must however remain that of the customer and any Designers or Consultants concerned with the design and installation.

**Please Note:** We do not therefore accept any responsibility for matters of design, selection or specification or for the effectiveness of an installation containing one of our products unless we have been specifically requested to do so.

**All goods are sold subject to our Conditions of Sale and Warranty Terms, which are set out at the rear of this manual.**

In the interest of continuously improving the Torrent range, Gledhill Building Products Ltd reserve the right to modify the product without notice, and in these circumstances this document, which is accurate at the time of printing, should be disregarded. It will however be updated as soon as possible after the change has occurred.

## ISSUE 2: 06-10

### 1 DESCRIPTION

- 1.1 Torrent Direct
- 1.2 Torrent Indirect-SP
- 1.3 Torrent Indirect-OV
- 1.4 Torrent RE-Solar
- 1.5 Torrent Combi-Preheat
- 1.6 Torrent HP Range

### 2 MODEL SELECTION GUIDE AND TECHNICAL DATA

- 2.1 Model selection guide
- 2.2 Factory fitted and optional equipment
- 2.3 Technical data

### 3 COLD AND HOT WATER DISTRIBUTION NETWORK DESIGN

- 3.1 General
- 3.2 Use in hard water areas and scale prevention
- 3.3 Materials
- 3.4 Taps/Shower fittings
- 3.5 Hot and cold water supply pipe lengths
- 3.6 Water flow noise and water hammer

### 4 HEATING SYSTEM DESIGN

- 4.1 Ball valve and overflow
  - 4.1.1 Torrent Direct models
  - 4.1.2 Torrent Indirect and RE models
- 4.2 Water treatment
- 4.3 Torrent Direct system design
- 4.4 Torrent Indirect and Torrent RE-Solar heating system design
  - 4.4.1 General
  - 4.4.2 Pipe sizing and materials – heating system
  - 4.4.3 Boiler size
  - 4.4.4 Open vented heating system
  - 4.4.5 Sealed heating system
- 4.5 Solar heating systems
  - 4.5.1 General
  - 4.5.2 Torrent Direct – Solar
  - 4.5.3 Torrent RE-Solar
- 4.6 Other renewable energy sources

### 5 INSTALLATION

- 5.1 General
- 5.2 Torrent Direct
- 5.3 Torrent Indirect and Torrent RE-Solar
- 5.4 Solar heating – Torrent RE and Torrent Direct-solar
- 5.5 Other renewable energy sources

### 6 COMMISSIONING

- 6.1 Torrent Direct models
- 6.2 Non-Electric Torrent models
- 6.3 Important Do's and Don'ts

### 7 FAULT FINDING

- 7.1 Torrent direct-electric models
- 7.2 All other Torrent models

### 8 PARTS

### 9 Terms & conditions

# DESCRIPTION

Gledhill developed the principle of domestic thermal stores starting in 1982 and they have been manufacturing them in ever larger numbers since then. They are particularly important to the design of the systems in two main areas: -

- (a) Apartments – Where the discharge from the pressure and temperature relief valves on the unvented cylinders could be a problem. Because this product does not require a safety discharge from a temperature and pressure relief valve, any installation will be easy to incorporate into the building and will not suffer the problems facing unvented cylinders now that discharges into PVCu soil stacks are not permitted.
- (b) Alternative energy – Where a primary thermal store can be heated by a solid fuel and/or heat pump and or solar thermal system without the risk of legionella or the risks associated with high temperature and pressures. The secondary water volume is so small that the “dwell time” is tiny which is the reason why there is virtually no legionella risk unlike a storage vessel.

Torrent range of primary thermal stores are designed to provide mains pressure hot water without the additional safety requirements of a pressure and temperature relief valve. Therefore, unlike with the unvented cylinder, the notification to the Building Control to comply with section G3 of the Building Regulations is not required. This is because the thermal store is vented in the normal way and the mains pressure hot water is heated instantaneously by means of heat exchangers inside the thermal store as shown in figures 1.1 – 1.5. The domestic hot water heat exchanger contains its own self replenishing expansion chamber to absorb the expansion of the domestic hot water inside the appliance.

Unlike unvented storage cylinders, the Torrent range of mains pressure hot water units require no annual maintenance or inspection. This reduces the running cost for the home owner while offering high performance showers and high flow rates to fill baths rapidly.

The Torrent model selection guidance is summarised in table 2.1 and the Torrent range is available in the following basic variants: -

## 1.1 TORRENT DIRECT

Torrent Direct is an electrically heated, fully packaged mains pressure hot water appliance which incorporates a feed and expansion cistern as shown in figure 1.1. Therefore it eliminates the problems associated with a cold water cistern in the roof space. It is supplied complete with two low watts density immersion heaters for extra quiet operation which are BEAB approved for safety.

A Torrent Direct-Solar model shown in figure 1.2, is also available for use with a solar thermal water heating system. The technical data of the Torrent Direct models is listed in table 2.3 in section 2.

## 1.2 TORRENT INDIRECT-OV

Torrent Indirect-OV shown in figure 1.3 is a vented primary thermal store that is designed for use with either a gas or an oil boiler and it provides mains pressure domestic hot water. The primary thermal store (i.e. the cylinder) of the Torrent Indirect-OV is heated directly by the boiler and therefore it is only suitable for open vented heating systems.

The primary hot water in the Torrent Indirect-OV models is used for producing domestic hot water and is also circulated through the central heating circuit for rapid heating of the dwelling.

The Torrent Indirect-OV models can be plumbed using the traditional 'Y' or 'S' plan control arrangements or alternatively, the central heating can be supplied using a separate pump directly from the store as described in section 4 of this manual. The technical data of the Torrent Indirect-OV models is presented in table 2.4 in section 2.

### 1.3 TORRENT INDIRECT-SP

Torrent Indirect-SP is a vented primary hot water store i.e. the cylinder is designed for use with a gas or an oil boiler and provides mains pressure domestic hot water (figure 1.4). Like all other Torrent models, the domestic hot water is heated instantaneously by means of internal heat exchangers. The primary thermal store of the Torrent Indirect-SP is heated indirectly by means of a primary heat exchanger (primary coil) and is used for heating domestic hot water only.

The Torrent Indirect-SP is primarily designed for use with sealed primary heating but it can be used for open vented systems provided separate cold feed and open vent are used for the heating circuit. The Torrent Indirect-SP models can be plumbed using the traditional 'Y' or 'S' plan control arrangements as described in section 4 of this manual. The technical data of this range is listed in table 2.5 in section 2.

### 1.4 TORRENT-RE – FOR USE SOLAR / WOOD BURNING STOVE / AGA

The Torrent-RE-Solar is based on the well proven, tried and tested Torrent range of thermal stores described above. It is designed for use with solar thermal systems in combination with a gas or an oil boiler. In addition to this, the Torrent-RE-Solar can also be connected to other renewable energy heat sources e.g. wood burning stove, AGA. The connections for wood burning stove and any additional connections for other heat sources or additional heating circuits can be specified when placing the order.

All Torrent-RE-Solar models are available for use in traditional open vented (OV) heating systems as shown in figure 1.5 or with an additional primary (boiler) heat exchanger for use in a sealed primary (SP) heating systems as shown in figures 1.6. However in both cases the thermal store is always open vented so that other renewable heat sources can be connected to it safely. In both variants, the solar panels heat the store by means of a solar heat exchanger inside the store.

In the Torrent-RE-Solar OV models, the thermal store is heated directly by the boiler and/or the wood burning stove (if fitted) and the central heating is supplied from the thermal store. In the Torrent-RE-Solar SP models, the thermal store is heated indirectly by the boiler and directly by the wood burning stove (if fitted) and the central heating is supplied directly from the boiler circuit. The technical data of these models is listed in tables 2.6 and 2.7 in section 2.

### 1.5 TORRENT COMBI-PREHEAT

This Torrent variant is designed to provide solar pre-heated mains pressure hot water to a combination boiler without the risk of legionella. The thermal store is heated either directly (e.g. a drain back system) or indirectly by means of an internal solar heat exchanger i.e. a pressurised solar circuit). In both types, the thermal store is open vented. Horizontal models are available for use in a loft space with restricted height.

A typical system configuration of solar heating system designed to provide pre-heated mains pressure hot water to a combination boiler is shown schematically in figure 1.7. The technical specification of the Torrent Combi-preheat models is shown in table 2.8 in the specification section 2 of this manual.

# DESCRIPTION

## 1.6 TORRENT HP RANGE

Gledhill produce storage vessels specifically designed for use with heat pumps. Please ask for Torrent HP / Stainless Lite HP literature or visit our website [www.gledhill.net](http://www.gledhill.net). Our heat pump range includes: -

- (a) **Torrent-HP:** These are primary thermal stores of up to 450 litre capacity and designed for use with heat pumps. It provide mains pressure domestic like the standard Torrent but with solar and wood burning stove options.
- (b) **Stainless Lite HP:** These are unvented cylinders with up to 400 litre capacity and with enhanced primary heat exchangers and some models have solar option.
- (c) **Stainless Lite BS:** These are stainless steel buffer stores of up to 400 litre capacity. These are designed for use in large domestic and commercial heat pump circuits with operating pressures up to 3.0bar.

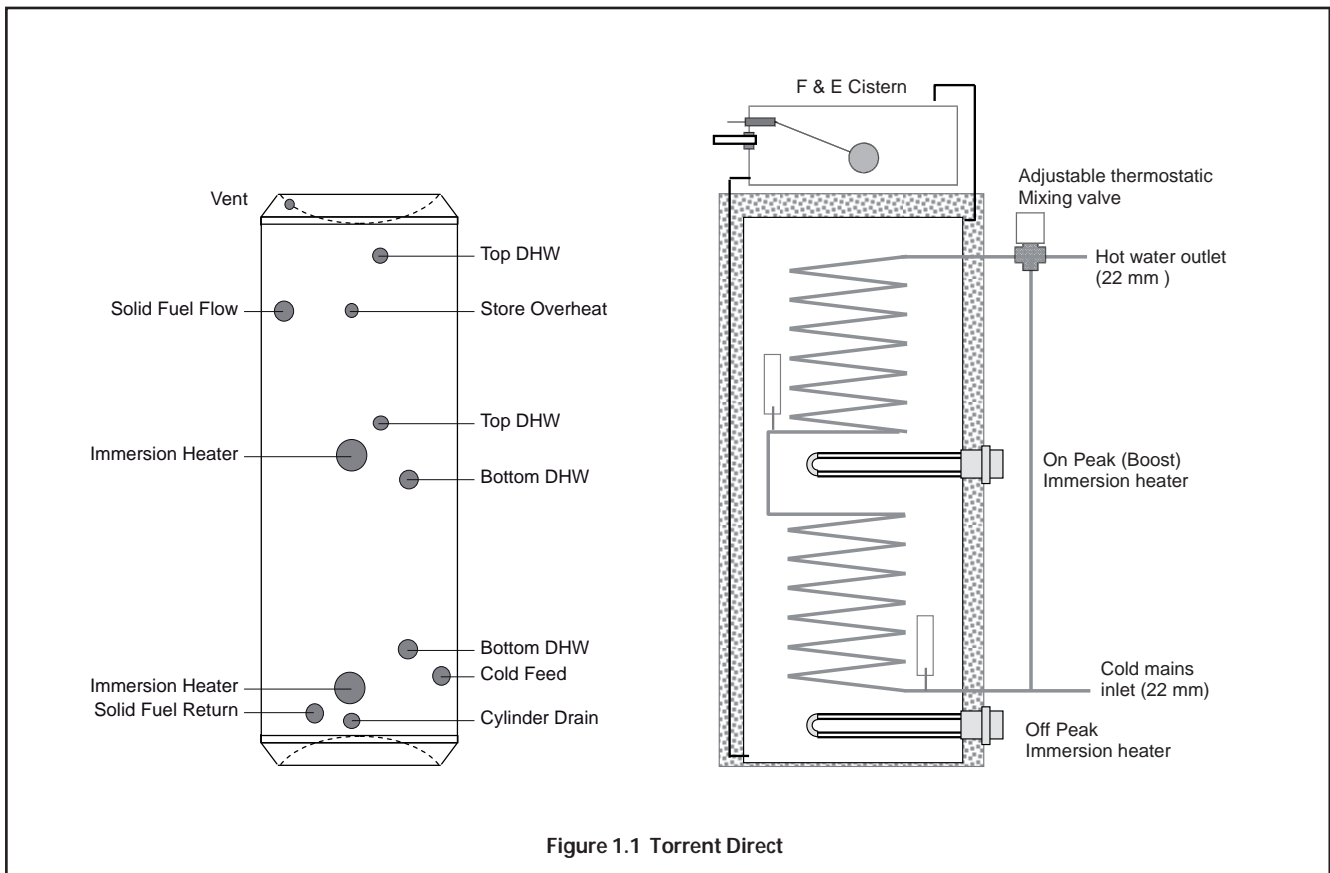

Please note Figures 1.1 to 1.7 are shown schematically only

# DESCRIPTION

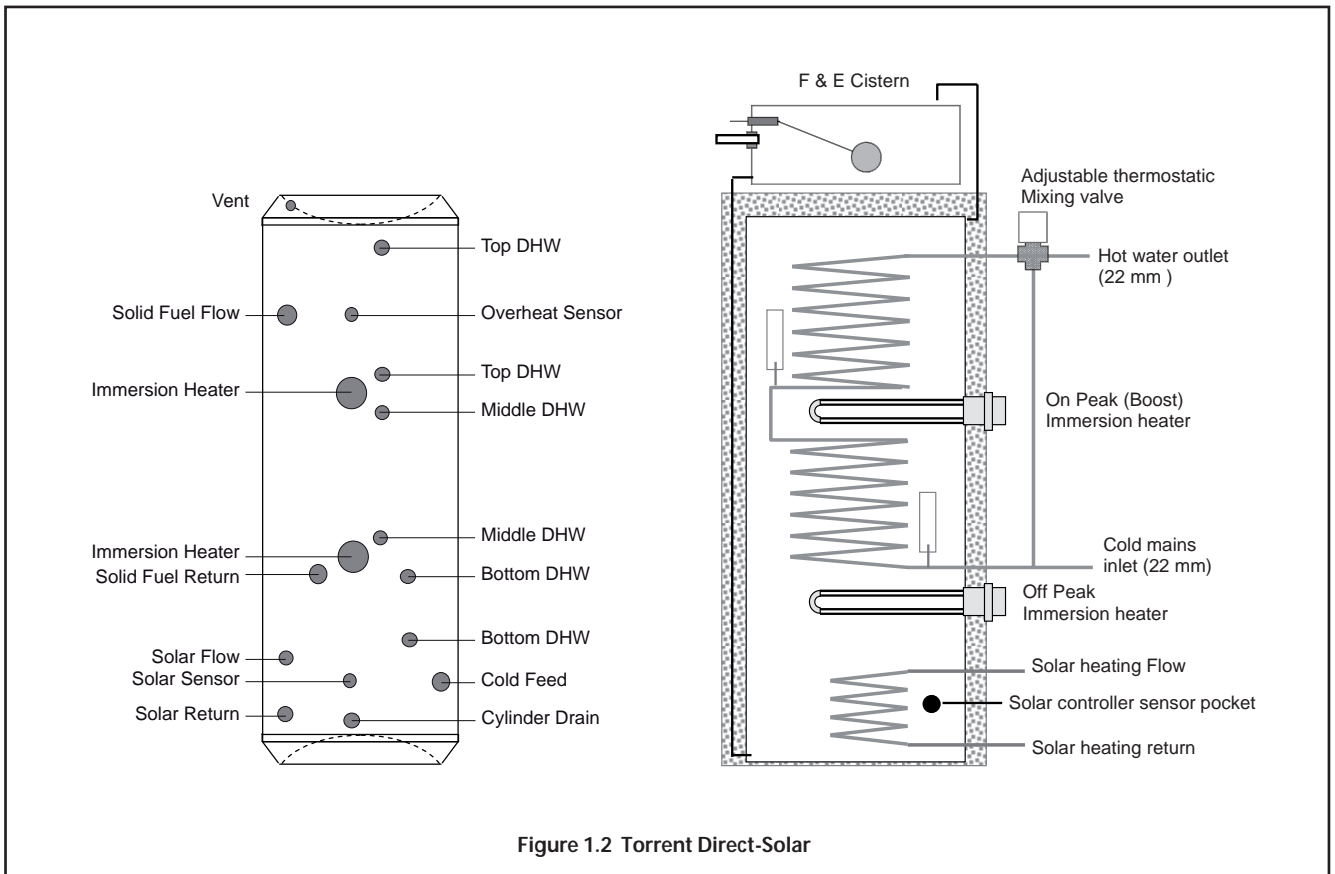

Figure 1.2 Torrent Direct-Solar

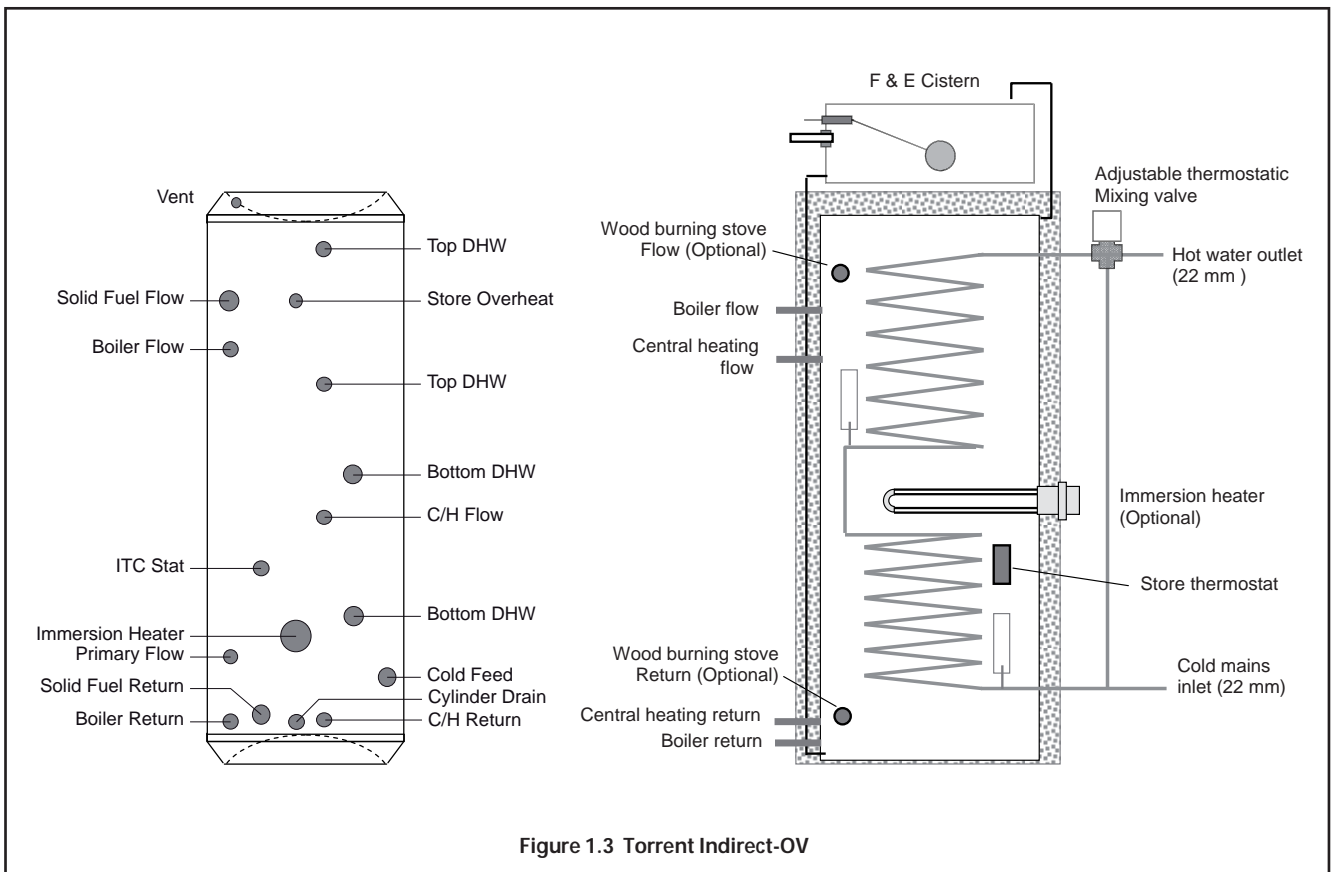
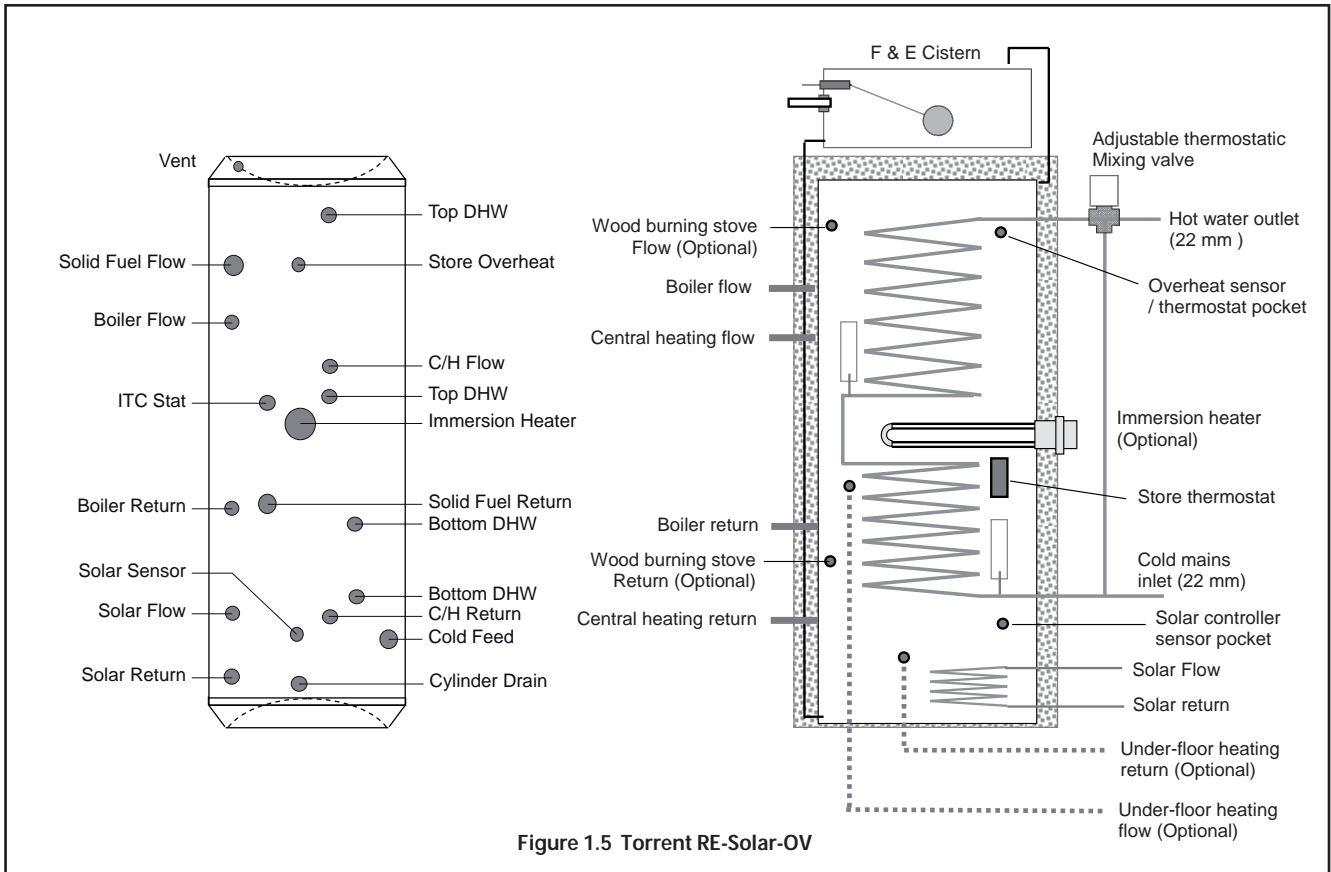
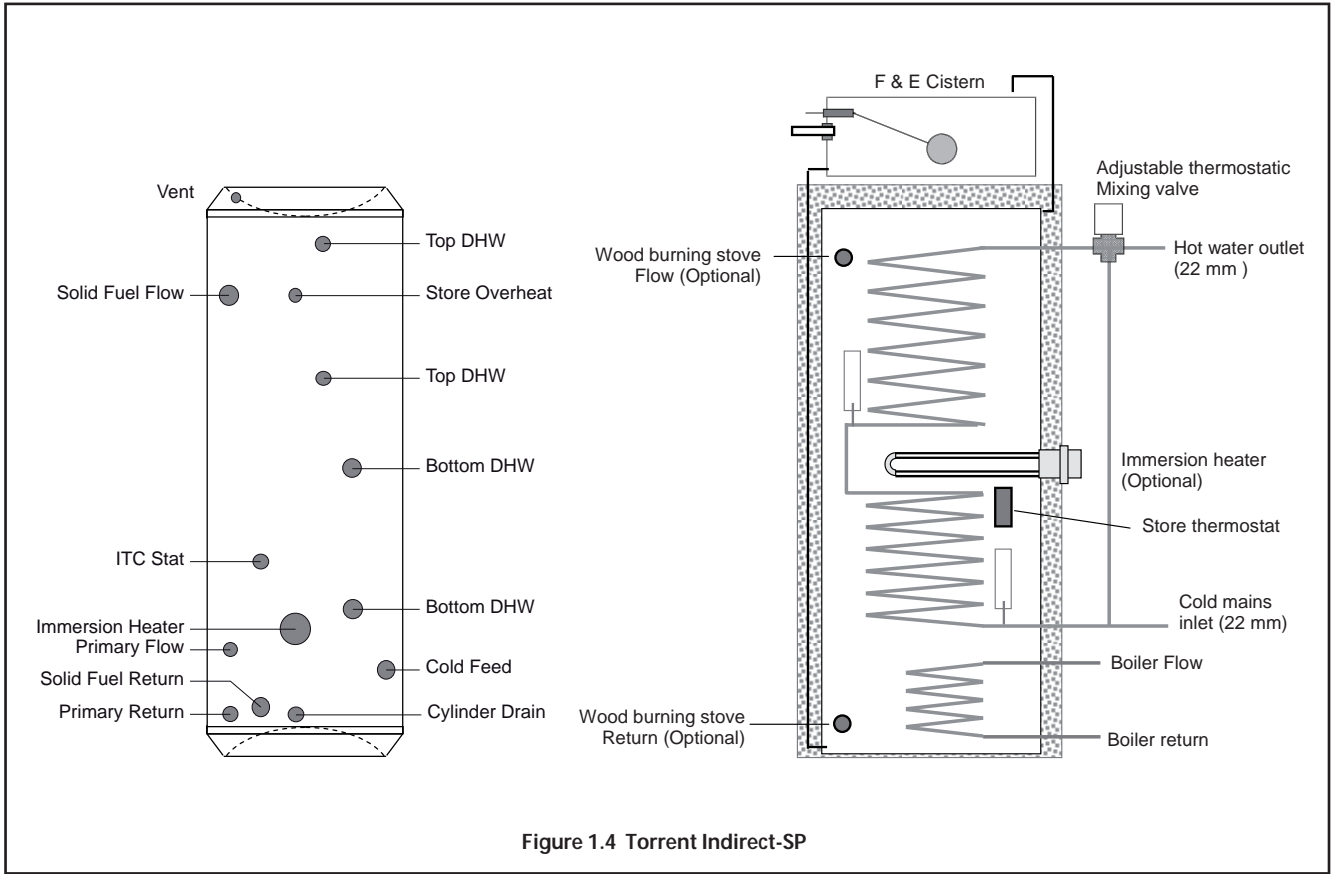

Figure 1.3 Torrent Indirect-OV

UNIT DIAGRAMS

# DESCRIPTION



UNIT DIAGRAMS



# DESCRIPTION

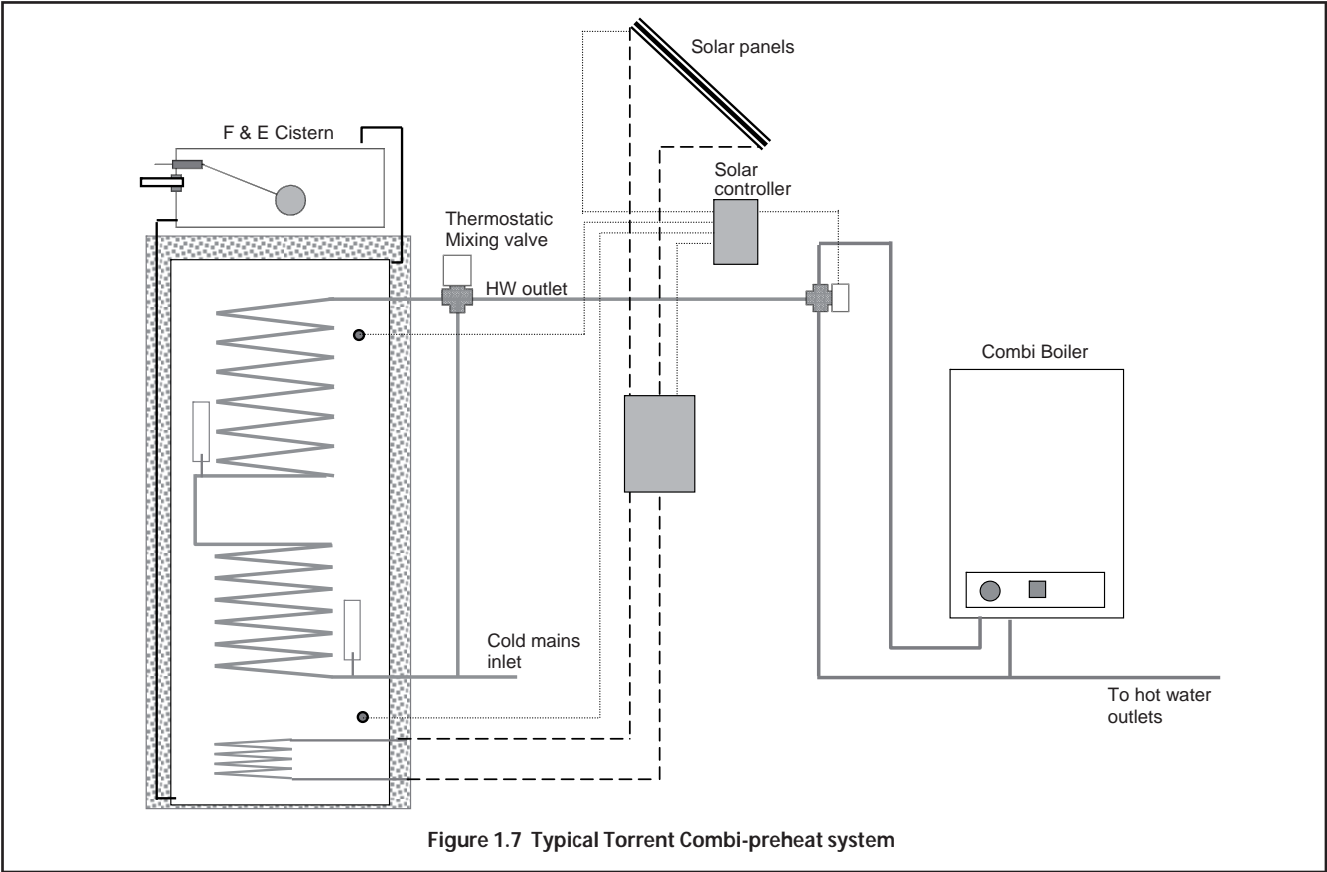
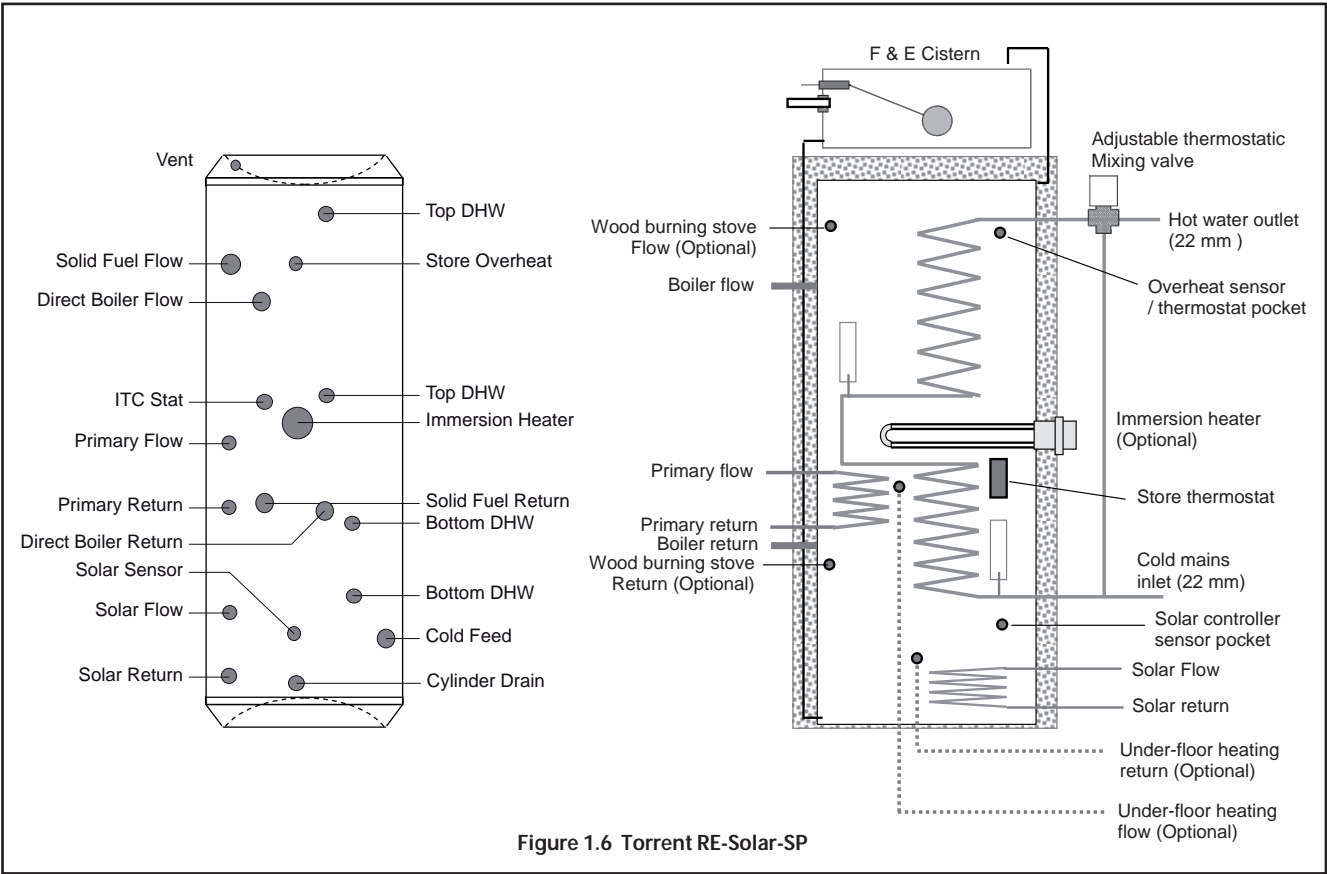

UNIT DIAGRAMS

# TECHNICAL DATA

## 2.1 MODEL SELECTION GUIDE

The suggested model sizes shown in the table 2.1 are based on a typical daily hot water usage and on the assumptions that the heating system is correctly sized and that the thermal store is heated to at least 75°C by the main heat source. It is recommended that for higher specification, an increase of one model size should be considered.

When selecting a Torrent-RE model, the following operating and the compliance requirement parameters should also be taken into account: -

- (a) The primary heat source (e.g. a boiler) will only heat about 65% of the store volume and the remainder is designed to be heated by the solar thermal system. During the winter period the solar contribution will be negligible and this should be taken into account when selecting the Torrent-RE models.
- (b) The solar heating systems and the associated equipment should comply with the 'Building Regulations' and these requirements are specified in the '*Heating system compliance guide*'. (See [www.gledhill.net](http://www.gledhill.net)). The key requirements relevant to the model selection are: -
  - Either the total floor area,  $A_D$ , of the dwelling should not be greater than the value stated for the model in table 2.1 as illustrated by example 1 below; or the dedicated solar volume for the model selected should not be less than the value ' $25 \times A_P$ '; where,  $A_P$ , is the total net area of the solar panels in  $m^2$  as illustrated by example 2 below.

### Example 1:

The total floor area,  $A_D$ , of the dwelling =  $130m^2$ .

Therefore from table 2.1, the smallest Torrent model that will comply with the requirements will be T350RE.

### Example 2:

Total net area of the solar panels,  $A_P$ , to be installed =  $3.0m^2$ .

Therefore dedicated solar volume required =  $25 \times A_P = 25 \times 3.0 = 75$  litres

Therefore from table 2.1, the smallest Torrent model that will comply with this requirements will be T200RE.

- The surface area of the solar heat exchanger of the Torrent-RE model selected should not be less than the value ' $0.1 \times A_P$ ' for low flow rate solar panels ( $< 0.5$  l/min per  $m^2$ ) or less than the value ' $0.2 \times A_P$ ' for high flow rate solar panels ( $\geq 0.5$  l/min per  $m^2$ ); where,  $A_P$ , is the total net area of the solar panels in  $m^2$ .

### Example 3:

The net area,  $A_P$ , of the solar panels =  $2.5m^2$ ,

The manufacturers recommended flow rate,  $Q_{SP}$ , =  $0.4$  l/min per  $m^2$

Therefore, minimum surface area of solar heat exchanger required =  $2.5 \times 0.1 = 0.25m^2$

### Example 4:

The net area,  $A_P$ , of the solar panels =  $3.5m^2$ ,

The manufacturers recommended flow rate,  $Q_{SP}$ , =  $0.7$  l/min per  $m^2$

Therefore, minimum surface area of solar heat exchanger required =  $3.5 \times 0.2 = 0.7m^2$

## 2.2 OPTIONAL EQUIPMENT

A high limit thermostat is available as an option.

## 2.3 TECHNICAL DATA

The physical and the technical data for the Torrent range covered by this manual presented in tables 2.3 – 2.8. The reference notes for these tables are described below.

- [1] The maximum dwelling floor area calculated using SAP 2005 procedure for compliance with the Building Regulations 2000 relating to solar heating systems. For further guidance see *'Heating system compliance guide'*.
- [2] The maximum net area of solar panels calculated at 25l/m<sup>2</sup> of dedicated solar volume for compliance with the Building Regulations relating to solar heating systems. For further guidance see *'Heating system compliance guide'*.
- [3] Pressure loss characteristics of the primary (boiler) heat exchanger measured at 0.25 l/s flow rate as specified in BS 1566, BS EN 12897 and *'Performance specification of thermal stores', an HWA publication*.
- [4] Pressure loss characteristics of the solar heat exchanger measured at 0.25 l/s flow rate as BS EN 12897 and *'Performance specification of thermal stores', an HWA publication*.
- [5] Performance rating of the primary (boiler) heat exchanger measured using procedure defined in the *'Performance specification of thermal stores', an HWA publication*.
- [6] Hot water performance measured at store charge temperature of 75°C, mains inlet pressure of 2.0bar and the dhw mixing valve set at 55°C.

Table 2.1 Torrent model selection guide

Dwelling type	Bath rooms & shower rooms	Suggested models			
		Torrent Direct	Torrent Direct - Solar	Torrent Indirect OV & SP	RE-Solar
1 – 2 Bedrooms	1 bathroom	T144 DE	T210DE-RE [1] A <sub>D</sub> up to 60 m <sup>2</sup> [2] A <sub>P</sub> up to 2.8 m <sup>2</sup>	T130IND	T170RE : [1] For A <sub>D</sub> up to 55 m <sup>2</sup> [2] For A <sub>P</sub> up to 2.6 m <sup>2</sup>
2 – 3 Bedrooms	1 Bathroom or 1 Shower room	T210 DE		T130IND	T170RE : [1] For A <sub>D</sub> up to 55 m <sup>2</sup> [2] For A <sub>P</sub> up to 2.6 m <sup>2</sup>
2 – 3 Bedrooms	1 Bathroom and 1 shower room			T130IND	T170RE : [1] For A <sub>D</sub> up to 55 m <sup>2</sup> [2] For A <sub>P</sub> up to 2.6 m <sup>2</sup> T210RE : [1] For A <sub>D</sub> up to 70 m <sup>2</sup> [2] For A <sub>P</sub> up to 3.0 m <sup>2</sup>
2 – 4 Bedrooms	1 Bathroom and 1 shower room			T170IND	T200RE : [1] For A <sub>D</sub> up to 70 m <sup>2</sup> [2] For A <sub>P</sub> up to 3.0 m <sup>2</sup> T280RE : [1] For A <sub>D</sub> up to 100 m <sup>2</sup> [2] For A <sub>P</sub> up to 3.8 m <sup>2</sup>
3 – 4 Bedrooms	2 Bathroom and 1 shower room			T210IND	T280RE : [1] For A <sub>D</sub> up to 100 m <sup>2</sup> [2] For A <sub>P</sub> up to 3.8 m <sup>2</sup> T350RE : [1] For A <sub>D</sub> up to 160 m <sup>2</sup> [2] For A <sub>P</sub> up to 5.0 m <sup>2</sup>
3 – 5 Bedrooms	3 Bathrooms and 2 Shower rooms				T350RE : [1] For A <sub>D</sub> up to 160 m <sup>2</sup> [2] For A <sub>P</sub> up to 5.0 m <sup>2</sup> T450RE : [1] For A <sub>D</sub> up to 230 m <sup>2</sup> [2] For A <sub>P</sub> up to 6.1 m <sup>2</sup>
4 – 6 Bedrooms	5 bathrooms				T450RE : [1] For A <sub>D</sub> up to 230 m <sup>2</sup> [2] For A <sub>P</sub> up to 6.1 m <sup>2</sup>

Table 2.3 Technical data for the Torrent Direct models (Figures 1.1 & 1.2)

	Model	T144DE	T210DE	T210DE-RE
Nominal storage volume (capacity)	[ litres ]	160	230	230
Overall dimensions: (Height x Diameter) <b>Note: Includes F &amp; E cistern</b>	[ mm ]	1650 x 550	1670 x 595	1670 x 595
Minimum cupboard size: (Width x Depth x Height)	[ mm ]	700 x 600 x 1900	750 x 600 x 2120	750 x 600 x 2120
Weight: [ Empty / Full ]	[ kg / kg ]	37 / 197	45 / 272	53 / 282
Volume heated by top immersion heater	[ litres ]	70	90	60
Maximum working head - Store	[ mWG ]	10.0	10.0	10.0
Mains cold water inlet pressure range	[ bar ]	1.5 – 3.5	1.5 – 3.5	1.5 – 3.5
Hot water flow rate <sup>[4]</sup>	[ litres/min ]	15	15	15
Heat loss factor	[ kWh/24h ]	2.4	2.5	2.5
Dedicated solar volume	[ litres ]			70
Area of the solar heat exchanger	[ m <sup>2</sup> ]			1.30
Maximum working pressure – solar heat exchanger	[ bar ]			6.0
Maximum floor area of the dwelling <sup>[1]</sup>	[ m <sup>2</sup> ]			60.0
Maximum net area of the solar collector <sup>[2]</sup>	[ m <sup>2</sup> ]			2.8
Connections - Cold feed - Open vent - Drain valve - Solar heat exchanger		22 mm, comp 22 mm, comp R1/2" -----	22 mm, comp 22 mm, comp R1/2" -----	22 mm, comp 22 mm, comp R1/2" 15 mm, comp
Off peak & On peak immersion heaters		2 off 3kW; 230Vac, 50Hz (Type 2)		

# TECHNICAL DATA

## TORRENT INDIRECT OV

Table 2.4 Technical data for the Torrent Indirect OV models for use with gas/oil boiler and open vented heating system		T130 IND-OV	T170 IND-OV	T210 IND-OV	T250 IND-OV
Nominal storage capacity	[ litres ]	135	176	216	256
Overall dimensions [ Includes F & E cistern ] Height x Diameter	[ mm ]	1545 x 520	1865 x 520	1835 x 570	2080 x 570
Minimum cupboard size - Width x Depth x Height	[ mm ]	700 x 600 x 1880	700 x 600 x 2100	700 x 600 x 2200	700 x 600 x 2450
Weight [ Empty / Full ]	[ kg / kg ]	30 / 157	37 / 204	38 / 243	46 / 288
Maximum working pressure - Store (Open vented) - Heating system (Open vented)	[ mWG ] [ mWG ]	10.0 10.0	10.0 10.0	10.0 10.0	10.0 10.0
Mains cold water inlet pressure range	[ bar ]	1.5 – 3.0	1.5 – 3.0	1.5 – 3.0	1.5 – 3.0
Hot water flow rate <sup>[4]</sup>	[ l/min ]	18	18	25	25
Typical boiler size required <sup>5]</sup>	[ kW ]	10-15	15-20	20-25	25-30
Heat loss factor	[ kWh/24h ]	2.8	2.9	2.9	3.0
Connections - Cold feed - Open vent - Boiler flow & return - Central heating flow & return - Wood burning stove (optional) - Drain valve		22 mm 22 mm 22 mm 22 mm 28 mm R1/2"	22 mm 22 mm 22 mm 22 mm 28 mm R1/2"	22 mm 22 mm 28 mm 28 mm 28 mm R1/2"	22 mm 22 mm 28 mm 28 mm 28 mm R1/2"

Table 2.5 Technical data for the Torrent Indirect SP models for use with gas/oil boiler and sealed heating system				
	T130 IND-SP	T170 IND-SP	T210 IND-SP	T250 IND-SP
Nominal storage capacity	135 [ litres ]	176	216	256
Overall dimensions [ Includes F & E cistern ] Height x Diameter	1545 x 520 [ mm ]	1865 x 520	1835 x 570	2080 x 570
Minimum cupboard size - Width x Depth x Height	700 x 600 x 1880 [ mm ]	700 x 600 x 2100	700 x 600 x 2200	700 x 600 x 2450
Weight [ Empty / Full ]	36 / 163 [ kg / kg ]	43 / 210	46 / 251	54 / 296
Maximum working pressure - Store (Open vented) - Heating system (sealed)	10.0 3.5 [ mWG ] [ bar ]	10.0 3.5	10.0 3.5	10.0 3.5
Mains cold water inlet pressure range	1.5 – 3.0 [ bar ]	1.5 – 3.0	1.5 – 3.0	1.5 – 3.0
Hot water flow rate <sup>[4]</sup>	18 [ l/min ]	18	25	25
Typical boiler size required <sup>[5]</sup>	20 [ kW ]	20	25	25
Heat loss factor	2.8 [ kWh/24h ]	2.9	2.9	3.0
Connections - Cold feed - Open vent - Boiler flow & return - Central heating flow & return - Wood burning stove (optional) - Drain valve	22 mm 22 mm 22 mm 22 mm 28 mm R1/2"	22 mm 22 mm 22 mm 22 mm 28 mm R1/2"	22 mm 22 mm 28 mm 28 mm 28 mm R1/2"	22 mm 22 mm 28 mm 28 mm 28 mm R1/2"
Primary (boiler) heat exchanger - Maximum working pressure - Rating - Water content	3.0 20 5.0 [ bar ] [ kW ] [ litres ]	3.0 25 6.0	3.0 30 7.0	3.0 35 8.0

# TECHNICAL DATA

## TORRENT RE OV

Table 2.6 Technical data for the Torrent RE-OV models for use with solar thermal, gas/oil boiler and open vented central heating		T170RE-OV	T210RE-OV	T280RE-OV	T350RE-OV	T450RE-OV
Nominal storage capacity	[ litres ]	176	206	286	381	482
Dedicated solar volume	[ litres ]	65	76	95	125	153
Maximum dwelling floor area <sup>[1]</sup>	[ m <sup>2</sup> ]	55	70	100	160	230
Maximum net area of solar panels <sup>[2]</sup>	[ m <sup>2</sup> ]	2.6	3.0	3.8	5.0	6.1
Overall dimensions [ <i>Includes F &amp; E cistern</i> ] Height x Diameter	[ mm ]	1880 x 520	2135 x 520	2265 x 570	2265 x 680	2265 x 680
Minimum cupboard size - Width x Depth x Height	[ mm ]	700 x 600 x 2150	700 x 600 x 2400	700 x 600 x 2500	700 x 700 x 2500	700 x 700 x 2500
Weight : Empty / Full	[ kg / kg ]	45 / 210	49 / 244	61 / 326	75 / 425	85 / 535
Maximum working pressure (head) - Store (Open vented ) - Central heating (Open vented)	[ mWG ] [ mWG ]	10.0 10.0	10.0 10.0	10.0 10.0	10.0 10.0	10.0 10.0
Mains water inlet pressure range	[ bar ]	1.5 – 3.0	1.5 – 3.0	1.5 – 3.0	1.5 – 3.0	1.5 – 3.0
Hot water flow rate <sup>[1]</sup>	[ l/min ]	18	18	25	25	35
Typical boiler size required <sup>[2]</sup>	[ kW ]	20	20	25	30	40
Heat loss factor	[ kWh/24h ]	2.9	2.9	3.1	3.2	3.4
Connections - Cold feed - Open vent - Boiler flow & return - Central heating flow & return - Wood burning stove - Solar flow & return - Drain valve		22 mm 22 mm 22 mm 22 mm 28 mm 22 mm R1/2"	22 mm 22 mm 22 mm 22 mm 28 mm 22 mm R1/2"	22 mm 22 mm 28 mm 28 mm 28 mm 22 mm R1/2"	22 mm 22 mm 28 mm 28 mm 28 mm 22 mm R1/2"	22 mm 22 mm 35 mm 35 mm 28 mm 28 mm R1/2"
Solar heat exchanger - Maximum working pressure - Surface area - Water content	[ bar ] [ m <sup>2</sup> ] [ Litres ]	6.0 1.31 3.0	6.0 1.31 4.0	6.0 1.74 5.0	6.0 1.74 6.0	6.0 2.2 6.0



Table 2.7 Technical data for the Torrent RE-SP models for use with solar thermal, gas/oil boiler and Sealed central heating						
	T170RE-SP	T210RE-SP	T280RE-SP	T350RE-SP	T450RE-SP	
Nominal storage capacity	176	206	286	381	482	[ litres ]
Dedicated solar volume	65	76	95	125	153	[ litres ]
Maximum dwelling floor area <sup>[1]</sup>	55	70	100	160	230	[ m <sup>2</sup> ]
Maximum net area of solar panels <sup>[2]</sup>	2.6	3.0	3.8	5.0	6.1	[ m <sup>2</sup> ]
Overall dimensions [ <i>Includes F &amp; E cistern</i> ] Height x Diameter	1880 x 520	2135 x 520	2265 x 570	2265 x 680	2265 x 680	[ mm ]
Minimum cupboard size - Width x Depth x Height	700 x 600 x 2150	700 x 600 x 2400	700 x 600 x 2500	700 x 700 x 2500	700 x 700 x 2500	[ mm ]
Weight : Empty / Full	51 / 216	57 / 252	69 / 334	75 / 425	85 / 535	[ kg / kg ]
Maximum working pressure (head) - Store (Open vented ) - Central heating	10.0 3.5	10.0 3.5	10.0 3.5	10.0 3.5	10.0 3.5	[ mWG ] [ bar ]
Mains water inlet pressure range	1.5 – 3.0	1.5 – 3.0	1.5 – 3.0	1.5 – 3.0	1.5 – 3.0	[ bar ]
Hot water flow rate <sup>[1]</sup>	18	18	25	25	35	[ l/min ]
Typical boiler size required <sup>[2]</sup>	15-20	15-20	20-25	25-30	30-40	[ kW ]
Heat loss factor	2.9	2.9	3.1	3.2	3.4	[ kWh/24h ]
Connections						
- Cold feed	22 mm	22 mm	22 mm	22 mm	22 mm	
- Open vent	22 mm	22 mm	22 mm	22 mm	22 mm	
- Boiler flow & return	22 mm	22 mm	28 mm	28 mm	35 mm	
- Central heating flow & return	22 mm	22 mm	28 mm	28 mm	35 mm	
- Wood burning stove flow & return	28 mm	28 mm	28 mm	28 mm	28 mm	
- Solar flow & return	22 mm	22 mm	22 mm	22 mm	28 mm	
- Drain valve	R1/2"	R1/2"	R1/2"	R1/2"	R1/2"	
Primary heat exchanger						
- Maximum working pressure	3.0	3.0	3.0	3.0	3.0	[ bar ]
- Rating	15	20	25	30	35	[ kW ]
- Water content	5	6	7	8	10	[ litres ]
Solar heat exchanger						
- Maximum working pressure	6.0	6.0	6.0	6.0	6.0	[ bar ]
- Surface area	1.31	1.31	1.74	1.74	2.2	[ m <sup>2</sup> ]
- Water content	3.0	4.0	5.0	6.0	6.0	[ Litres ]

Table 2.8 Technical data for the Torrent Combi-preheat models

	T120 CP	T150 CP	T120 CP-H
Nominal storage capacity	130 [ litres ]	170	130
Overall dimensions [ Includes F & E cistern ] Height x Diameter	TBA [ mm ]	TBA	TBA
Weight [ Empty / Full ]	TBA [ kg / kg ]	TBA	TBA
Maximum working pressure - open vented store	10.0 [ mWG ]	10.0	10.0
Mains cold water inlet pressure range	1.5 – 3.0 [ bar ]	1.5 – 3.0	1.5 – 3.0
Hot water flow rate <sup>[4]</sup>	12 [ l/min ]	15	12
Heat loss factor	2.8 [ kWh/24h ]	2.9	2.8
Connections			
- Cold feed	15 mm	15 mm	15 mm
- Open vent	22 mm	22 mm	22 mm
- Solar circuit flow & return	15 mm	15 mm	15 mm
- Drain valve	R1/2"	R1/2"	R1/2"

## 3.1 GENERAL

- (a) A typical arrangement of the hot and cold water system is shown in figure 3.1. All Torrent models are designed to be fed directly from the mains and they fulfil the requirements of Water Bylaw 91, and therefore do not require a check valve to be fitted to the cold water supply pipe.
- (b) The performance of the Torrent is directly related to the cold water supply pressure and volume to the dwelling. This must be capable of providing for all those services which could be required simultaneously and the maximum demand should be calculated for sizing the distribution network.

As a general guideline, although a 15mm external service may be sufficient for the smaller dwelling with one bathroom, a 22mm service is preferred (25mm MDPE) and should be the minimum for larger dwellings.

- (c) The Torrent will operate at dynamic pressure as low as 1.5 bar (at the appliance) which must be available when the local demand is at its maximum, but the preferred range is between 2 and 3.5 bar.

If the incoming static mains pressure exceeds 3.5bar at any point in the 24 hour cycle, then a pressure limiting valve set at 3.0 bar should be fitted downstream of the stop tap where the cold supply enters the dwelling.

- (d) If a water meter is fitted in the service pipe, it should have nominal rating to match the anticipated maximum simultaneous hot and coldwater demand, calculated in accordance with BS 6700. This could be up to 50 l/min in some properties.
- (e) The equipment used in the system should be suitable for a working pressure of 10 bar and the units must be fitted strictly in accordance with the requirements of the Local Water Undertaking and the relevant Water Bylaws.

## 3.2 USE IN HARD WATER AREAS AND SCALE PROTECTION

The patented design of the domestic hot water heat exchanger is such that the turbulence through the coil slows down the formation of the scale in moderate hard water conditions. However, the requirements set out in the '*Domestic Heating Compliance Guide*' and the *Building Regulations approved documents L1A and L1B* regarding scale protection should be complied with.

These requirements state that; "*where the mains water hardness exceeds 200ppm provision should be made to treat the feed water to the water heaters and the hot water circuit of combination boilers to reduce rate of accumulation of scale*". To comply with this requirement: -

- (a) The hardness of the mains water should be checked by the installer and if necessary suitable in-line scale inhibitor device should specified for hardness levels between 200 and 300ppm (mg/l).
- (b) Where the hardness level is 300ppm (mg/l) and above, the optional phosphate type inhibitor should be specified and fitted at a suitable point in the cold water supply to the appliance.

It is important that where the supply to the Torrent is in 22mm the in-line scale inhibitor is also 22mm. In practice servicing is not normally required but in hard water areas, the requirements can be considered similar to those needed for instantaneous or 'combi' appliances.

The installation of scale inhibitor should be in accordance with the manufacturers instructions and Water Byelaws.

### 3.3 MATERIALS

All the recommendations with regard to the heating systems in this manual are generally based on BS/EN Standard copper pipework and fittings. However plastic pipework system can be used in place of copper as long as the:-

- (a) The chosen system is recommended for use in domestic heating systems by the manufacturers and it is installed fully in accordance with their recommendations.
- (b) The design criterion of the plastic system is at least equivalent to the use of BS/EN Standard copper pipework and fittings.
- (c) The barrier pipework for these systems is recommended.

### 3.4 TAPS/SHOWER FITTING

- (a) Aerated taps are recommended to prevent splashing.
- (b) All types of shower mixing valves can be used as long as both hot and cold supplies are mains fed. However all mains pressure systems are subject to dynamic changes particularly when other hot and cold taps/showers are opened and closed, which will cause changes in the water temperature at the mixed water outlet such as showers. For this reason and because the thermostatic showers are now no more expensive than the manual showers, we strongly recommend thermostatic showers with Torrent. The shower head provided must also be suitable for mains pressure supplies.
- (c) The hot water supply to a shower-mixing valve should be fed where practical directly from the Torrent or be the first draw-off point on the hot circuit. The cold water supply to a shower-mixing valve should where practical be fed directly from the rising mains via an independent branch.
- (d) The shower must incorporate or be fitted with the necessary check valves to prevent back-syphonage protection in accordance with Water Regulations.
- (e) The supply of hot and cold mains water directly to the bidet is permitted provided that it is of the over-rim flushing type and that type 'A' air gap is incorporated.

### 3.5 HOT AND COLD WATER SUPPLY PIPE LENGTHS (DEADLEG VOLUMES)

- (a) If the length of the hot water draw-off pipework is excessive and the delivery time will be more than 60 seconds before hot water is available at the tap, you may wish to consider using trace heating to the hot water pipework such as the Raychem HWAT system.

Also a conventional pumped secondary circulation system (figure 3.2) can be used with any model of the Torrent.

- (b) It is important that the cold water pipework is adequately separated and protected from any heating from the hot water pipework to ensure that the water remains cold and of drinking water quality.

### 3.6 WATER FLOW NOISE AND WATER HAMMER

- (a) The water flow noise from the pipework is generally caused when the vibration/oscillation of pipe surface is induced by the water flowing through it. The water flow noise do not become significant provided the water velocity is kept below 3 m/s.

- (b) The water hammer is a pulsating type of noise which may be heard from the pipework installation or the hot water appliance. This noise is mainly caused by shock waves which are set up when water which is flowing at high velocity is suddenly stopped e.g. by rapidly closing tap or an instantaneously closing automatic control valve. Pumped water supplies in a building can create the water hammer if provision for absorbing the shock wave is not made during the design stage.

- (c) Shock pressures in the pipework supplied at high pressures can be reduced to acceptable limits by fitting water surge arrestors i.e. hydro-pneumatic accumulators in the pipe line at suitable points

The comprehensive sizing procedures are given in 'Plumbing Engineering Services Design Guide' and other such publications. As a rule of thumb for total pipe runs up to 50m and water pressure up to 4.0 bar; the following sizes of expansion vessels charged to the mains pressure may eliminate the water hammer

- 0.15 litre vessel for pipework in 15mm
- 0.25 litre vessel for pipework in 22mm
- 0.40 litre vessel for pipework in 28mm

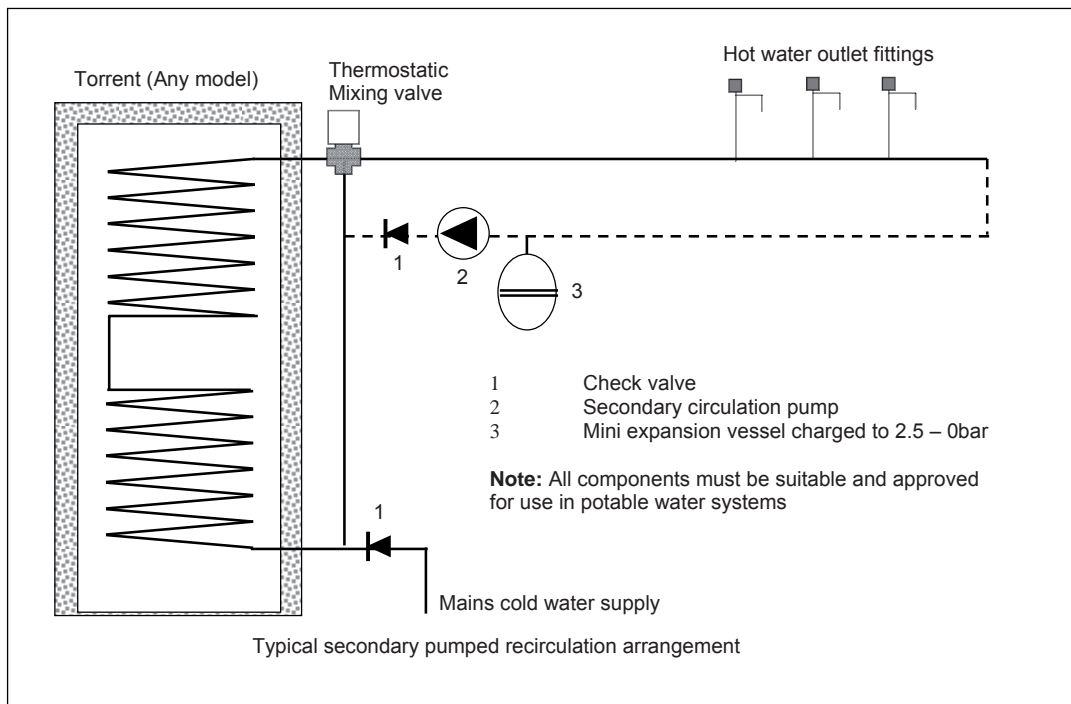
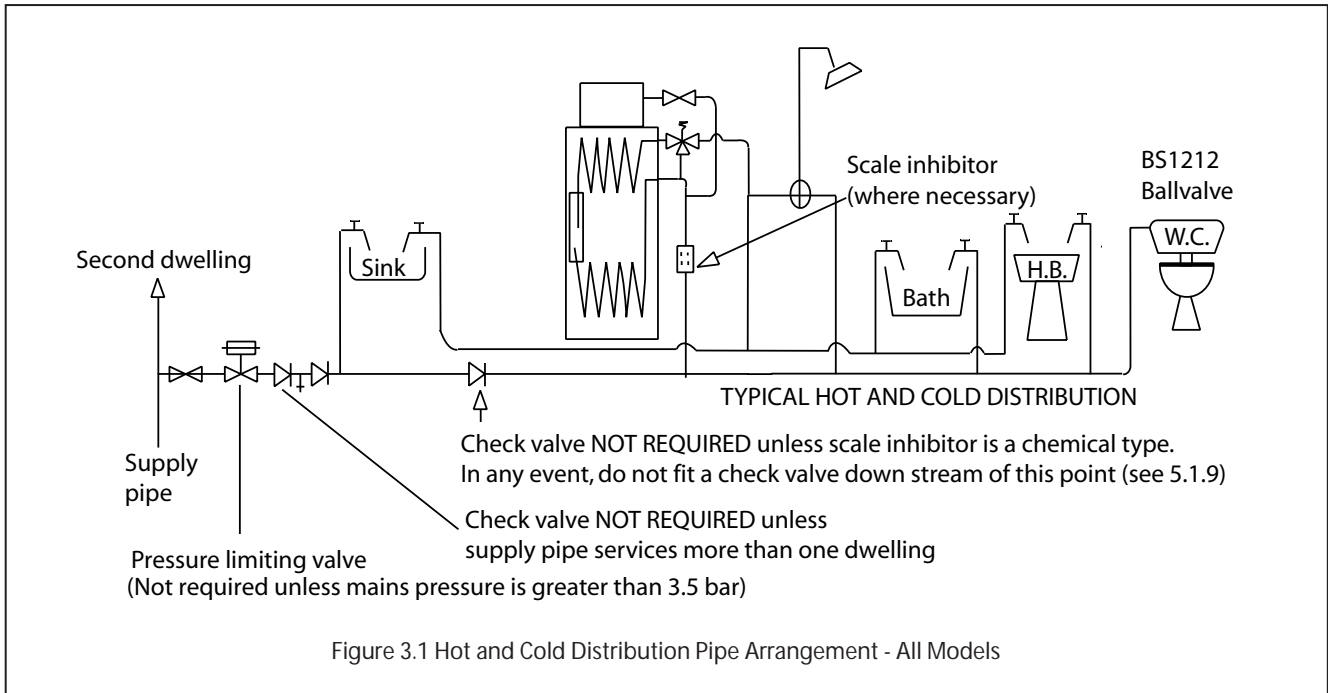

# HEATING SYSTEM DESIGN

## 4.1 BALL VALVE AND OVERFLOW

### 4.1.1 Torrent Direct models

The Torrent Direct models are designed for supplying hot water only and the feed and expansion cistern only supplies the thermal store. The feed and expansion cistern can be filled manually if required e.g. using a hose pipe fitted with a double check valve.

In this situation an overflow pipe can still be fitted if required to ensure that if a leak occurs on the internal dhw heat exchanger it can be discharged safely to the outside of the building.

**Note:** If a ball valve is fitted, then a warning/overflow pipe must always be fitted.

### 4.1.2 Torrent Indirect and Torrent RE-Solar models

These models are supplied with a feed and expansion cistern, ball valve and float. In most installations these supply the whole primary/heating system and therefore a ball valve and overflow pipe must be installed in the feed and expansion cistern.

## 4.2 WATER TREATMENT

In all Torrent models, the primary (i.e. non-potable) water is stored and the domestic hot water is heated instantaneously by means of heat exchangers. Therefore treating the primary water will not contaminate the domestic hot water supply.

Although the Torrent primary store has no special water treatment requirements, the radiators and other parts of the circuit will require the application of a scale and corrosion inhibitor. The volumes and concentration should be calculated in accordance with the manufacturers instructions and when calculating the system volume (i.e. the water content), the volume of the Torrent should be taken into account.

## 4.3 TORRENT DIRECT SYSTEM DESIGN

The Torrent Direct model shown in figure 1.1, has been designed to generally operate with an off-peak supply and is provided with two side entry 3kW immersion heaters. The lower immersion heater heats the whole of the store and is normally connected to the off-peak supply. The top immersion heater heats 50 – 70 litres of water (depending upon the model) at the top of the store. This is connected to the unrestricted on-peak supply and is switched on manually for a pre-set time period by the householder using the off-peak controller to boost the hot water if and when required.

The schematic arrangement of the wiring for the Torrent Direct is shown in figure 4.1. The whole of the electrical installation shall be designed and installed by a competent person and fully in accordance with the latest edition of the *'Requirements for Electrical Installations, BS 7671'*

# HEATING SYSTEM DESIGN

## 4.4 TORRENT INDIRECT & TORRENT RE-Solar HEATING SYSTEM DESIGN

### 4.4.1 General

- (a) The open vented i.e. the 'OV' models of the Torrent Indirect and the Torrent-RE are only suitable for open vented heating systems. The sealed primary i.e. the 'SP' models of the Torrent Indirect and the Torrent-RE are generally used for sealed primary (i.e. closed heating) systems. However in both cases, the thermal store must always be open vented.
- (b) No valve shall be fitted in the safety open vent and which must be a minimum of 22mm copper or equivalent.
- (c) The boiler must be set to operate at nominal 82°C flow which usually corresponds to the maximum boiler control thermostat setting.
- (d) All Torrent models are designed to be installed with condensing or non condensing oil or gas boiler which is capable of delivering hot water at a minimum temperature of 80°C.
- (e) It is recommended that where the central heating is supplied from the boiler circuit (e.g. Torrent Indirect SP models), an automatic bypass is fitted to compensate for pressure and hence the flow rate changes in the heating circuit e.g. when a thermostatic radiator valve closes. The bypass valve must be set by the installer to suit the system i.e. to provide minimum flow rate required for the boiler when all TRVs are closed.
- (f) It is important to ensure that both the primary store and the heating system are filled and vented before switching on the boiler and the immersion heater (if fitted).
- (g) If the Torrent is heated directly by the boiler (e.g. the OV models), then the boiler (or system pump) must be fitted in the return pipe from the store to the boiler. However if the Torrent is heated indirectly by the boiler via a heat exchanger (e.g. the SP models), then the boiler/system pump must be fitted in the flow pipe from the boiler to the store.
- (h) If the central heating is supplied directly from the store (e.g. the under-floor heating circuit in Torrent RE-Solar), then the central heating pump must be fitted in the flow pipe from the store to the heating circuit.
- (i) The Torrent models are supplied with an F&E cistern which is suitable for typical heating installations. If other heat sources are added or underfloor heating is used, then the F&E cistern should be upgraded to a larger one.

### 4.4.2 Pipe sizing and materials – heating system

- (a) All the recommendations with regard to the heating system in this manual are generally based on BS/EN Standard copper pipework and fittings. However, plastic pipework can be used in place of copper as long as the:
  - The chosen system is recommended for use in domestic heating systems by the manufacturers and it is installed fully in accordance with their recommendations.
  - The design criterion of the plastic system is at least equivalent to the use of BS/EN Standard copper pipework and fittings
  - A barrier pipework is used.
  - The use of plastic pipework for the boiler flow and return circuit adjacent to the boiler is done in accordance with the boiler manufacturers instructions.



# HEATING SYSTEM DESIGN

- (b) The feed and expansion cistern supplied with the thermal store can be fitted remotely up to 10m above the base of the Torrent i.e. the maximum static pressure in the store must not exceed 0.6 bar (6.0 mWG).
- (c) The primary pipe work connecting the boiler, thermal store and the central heating system should be sized to achieve either 11°C rise (BS 5449) across the boiler or the maximum temperature rise specified by the boiler manufacturer; whichever is smaller. But in any case should not be less than 22mm copper tube or equivalent.
- (d) The pressure loss through the primary heat exchangers of the Torrent Indirect models (see technical data tables in section 2) should be taken into account for sizing the pump and the pipe work.

## 4.4.3 Boiler Size

The minimum total boiler power required is the sum of the powered required for space heating which should be calculated in accordance with BS 5449 and the power required for producing hot water which can be read from table 4.1.

Table 4.1 Allowance for domestic hot water for sizing the boiler		
Torrent Model (Both 'OV' and 'SP' models)	Allowance for domestic hot water heating	
	Full divert mode	Flow share mode
T130IND, T130D	0	2
T170IND, T170D, T170RE	0	3
T210IND, T210D, T210RE	0	3.5
T280RE	0	4.5
T350RE	0	6.0
T450RE	0	8.0

## 4.4.4 Open vented heating systems

- (a) The open vented primary system is filled via the feed and expansion (F&E) cistern supplied with the Torrent Indirect 'OV' model and therefore it is important that the F&E cistern is positioned at least 250mm above the highest point in the system (see figures 4.2, 4.3 and 4.4).

Also ensure that the height of the F&E cistern is sufficient to meet the manufacturer's requirements for the minimum head required for the boiler and the system pump(s).

- (b) The Torrent Indirect 'OV' models can be installed using both 'Y' Plan and 'S' Plan heating system controls as shown schematically in figures 4.2 and 4.4. These models can also be installed without either 3-port or 2-port valves using a separate central heating pump as shown in figure 4.3. In this case no bypass valve is required.
- (c) If the flow and return pipes between the boiler and the Torrent-Indirect-OV thermal store are dipped as illustrated in figure 4.4, then the boiler selected must be suitable for a sealed heating system i.e. it must be fitted with an overheat thermostat. Automatic air vents should be fitted at appropriate places to vent the system and a pressure relief valve should also be fitted close to the boiler.
- (d) Any boiler can be used with OV variant of the Torrent-Indirect and the Torrent-RE provided the flow pipe from the boiler to the Torrent is continuously rising as shown in figures 4.2 and 4.3.

# HEATING SYSTEM DESIGN

The flow pipe between the boiler and the Torrent thermal store is part of the open vent and therefore it must not be fitted with any isolating valve, non-return valve or any other component which can obstruct the flow.

The minimum size of flow and return pipe between the boiler and the Torrent should be 22mm copper or equivalent. In any case it should be sized to suit the installed boiler capacity, available pump head and the circuit resistance.

- (e) The water level must be set correctly by adjusting the ball valve in the F&E cistern. A 22mm connection is provided for the overflow/warning pipe, which should be no less than the 20mm internal diameter and have a continuous fall.

The overflow/warning pipe should be fitted to discharge clear of the building and be sited so that any overflow can be easily observed. The warning pipe should be installed in either high temperature uPVC or copper and should not have any other connections to it.

## 4.4.5 Sealed heating system

- (a) All Torrent Indirect 'SP' models are suitable for sealed heating system up to 3.5bar maximum operating pressure, however the normal pressure relief valve setting is 3.0 bar. The typical layout of the open vented 'Y Plan' and 'S Plan' for the indirect Torrent models is shown in figures 4.5 and 4.6 respectively.
- (b) A boiler used in a sealed heating system must be suitable for this application i.e. it must be fitted with an overheat cut-out thermostat.
- (c) It is recommended that the F&E cistern (for the thermal store) is fitted at a high level in the same cupboard as the Torrent. However it can be fitted remotely up to 10m above the base of the Torrent.

The F&E cistern overflow/warning pipe should be installed in a material suitable for a heating system feed and expansion cistern in accordance with BS 5449.

- (d) There shall be no permanent connection to the mains water supply for filling the heating system even through a non-return valve without the approval of the Local Water Authority. An approved filling loop is required for filling the heating system, which should be disconnected after commissioning the system.

The filling loop should be located adjacent to the boiler along with a suitable expansion vessel, pressure gauge, pressure relief valve and discharge arrangement.

- (e) The table 4.2 can be used for sizing the heating system expansion vessel. The water content of the Torrent primary heat exchanger is listed in specification tables in section 2 (depending upon the model) and a figure of 4.5 l/kW of installed radiator capacity can be used for a preliminary assessment of the water content of the heating system.

The expansion vessel requirements shown in table 4.2 are based on a maximum boiler flow temperature of 93°C. The expansion vessel must be suitable to accommodate the change in volume of water in the heating system when heated from 10°C to 110°C as specified in BS 5449:1990 clause 16.2.

- (f) The minimum system pressure should not be less than the static head plus 0.5 bar i.e. the height of the highest point in the system above the expansion vessel plus a margin of 0.5 bar.

# HEATING SYSTEM DESIGN

Table 4.2 Expansion vessel requirements									
Safety valve setting	3.0								
Vessel charge pressure (bar)	0.5			1.0			1.5		
Initial system charge pressure (bar)	0.5	1.0	1.5	2.0	1.0	1.5	2.0	1.5	2.0
Total system volume (l)	Expansion vessel volume (l)								
25	2.1	3.5	6.5	13.7	2.7	4.7	10.3	3.9	8.3
50	4.2	7.0	12.9	27.5	5.4	9.5	20.6	7.8	16.5
75	6.3	10.5	19.4	41.3	8.2	14.2	30.9	11.7	24.8
100	8.4	14.0	25.9	55.1	10.9	19.0	41.2	15.6	33.1
125	10.4	17.5	32.4	68.3	13.6	23.7	51.5	19.5	41.3
150	12.5	21.0	38.8	82.6	16.3	28.5	61.8	23.4	49.6

## 4.5 SOLAR HEATING SYSTEM

### 4.5.1 General

- (a) All components in the solar primary system must be marked or identified in such a way that their design pressure and temperature can be readily determined.
- (b) A safety device (pressure relief valve) to control the risk of over-pressure in the solar heating system components should be fitted.
- (c) A termination from the safety pressure device should minimise the risk of injury to persons or damage to materials. Suitable locations are a high temperature receptacle, an internal gully or else discharge externally at ground level. High level termination from walls or on roofs could cause injury to people or animals below if the valve were to release scalding water or steam.
- (d) The pipes leading from the safety device to the collector should be rigid and non-deformable contraction without any possibility of restriction or disclosure by any other fitted component.
- (e) The Building Regulations 2000 specify the requirements for the storage vessels for use in solar heating systems. Therefore it is important to ensure that the Torrent model selected meets these requirements with regard to dedicated solar volume and the solar heat exchanger surface area.

### 4.5.2 Torrent Direct-Solar

- (a) A typical Torrent Direct-Electric solar heating system based on a generic solar controller is shown in figure 4.7.

Therefore general design requirements for hot and cold water systems (section 3), for Ball valve and overflow (section 4.1), for water treatment (section 4.2) and for heating system design (section 4.3) should be taken into account when designing the Torrent RE-solar based systems.

# HEATING SYSTEM DESIGN

## 4.5.3 Torrent RE-Solar

- (a) The Torrent RE-Solar is an advanced thermal store and has been designed to incorporate existing boiler and central heating controls and is based on the tried and tested standard Torrent range. Therefore general design requirements for hot and cold water systems (section 3), for Ball valve and overflow (section 4.1), for water treatment (section 4.2) and for heating system design (section 4.3) should be taken into account when designing the Torrent RE-solar based systems.
- (b) Figure 4.8 shows the Torrent RE 'OV' type used in a traditional open vented heating system and depending upon the location of the Torrent within the property, it would be possible to use the existing feed and expansion cistern. In any case the water level in the F&E cistern should be at least 250mm above the highest point of the heating system e.g. a radiator.
- (c) In the open vented 'OV' system shown in figure 4.8, the thermal store, radiator heating circuit and the under-floor heating circuit are all fed from the same feed and expansion cistern. Therefore it should be sized to accommodate the expansion of total water content of the complete system (i.e. water content of the store + water content of radiator heating circuit + water content of under-floor heating circuit).
- (d) Figure 4.9 shows the sealed primary 'SP' variant of the Torrent RE-solar used in a typical sealed heating system. With this system arrangement, although the boiler and the radiator central heating circuits are sealed, both the store and the under-floor heating circuit (if installed) are open vented. Therefore the feed and expansion cistern should be sized to accommodate the expansion of total water content of the open vented system (i.e. water content of the store + water content of under-floor heating circuit).
- (e) Figures 4.8 and 4.9 also show typical configurations of a solar thermal system with Torrent RE-solar, which will accumulate the energy from more than one renewable energy sources (e.g. solar, wood burning stove).

In the open vented 'OV' system (figure 4.8), this energy is available for hot water and at low level for both radiator and under-floor (if installed) space heating circuits. However in the sealed primary 'SP' system configuration (figure 4.9), this energy is only available for hot water and at low levels for the under-floor space heating circuit (if installed).

- (f) For maximising the use of the renewable 'green' energy, the system should be managed and controlled so that the unnecessary firing of the boiler is kept to minimum. This can be achieved by combination of: -
  - Use the store to provide shower or a bath in the morning after the store has been charged or utilising the heat gained by the system from previous days solar energy input. Alternatively showering or bathing in the evening will utilise the energy that has been stored during the day from the solar system.
  - As with any system, hot water and space heating should be programmed according to house holder requirements. However it is always good to remember that to gain maximum advantage from the solar panels, the store should be as cool as possible. To achieve this in spring, summer and autumn, the hot water channel of the boiler should be programmed to come on 30 minutes before the hot water is required in the morning and then programmed off before volumes of water are drawn off the system. This way the store is depleted of heat allowing maximum transfer from the solar system during the day.

# HEATING SYSTEM DESIGN

However further supplementary time periods for the boiler will be required in winter when not much solar energy is available.

- Uncontrolled boiler operation can also be reduced by fitting and wiring a pipe thermostat on the solar return pipe close to the Torrent RE-solar as shown in figures in section 5 '*Installation*'.

As part of setup and commissioning, it is important that this boiler hold-off pipe thermostat be adjusted to find the best setting for each individual installation. Failure to do so will give under performance of either the boiler or the solar heating system.

- (g) All models of Torrent RE-solar with the exception of the 210 DE-RE are supplied with two additional connections for the supplementary under-floor heating circuit as shown in figures 4.8 and 4.9. It is important to remember that the hot water will be immediately available from the thermal store and its temperature could be as high as 85°C. Therefore suitable blending valve and pumping station must be used to protect the under-floor heating circuit from high temperature water. The additional underfloor tappings can be requested on all other models.

#### 4.5.4 OTHER RENEWABLE ENERGY SOURCES – TORRENT RE-SOLAR

The Torrent RE-solar models have provision for connecting other alternative energy systems such as an Aga or wood burning stove in conjunction with the heat leak radiator system as shown in figure 4.10.

Although the thermal store is open vented (even when used with a sealed heating system) and therefore inherently safe, a heat leak system must be provided to prevent the possibility of boiling temperatures being reached in the thermal store. This is normally achieved by providing a suitable pipe thermostat on the alternative energy heat source flow pipe which is set at approximately 85 – 90°C and wired so that when this temperature is reached, the heating pump/zone valve will operate to allow excess heat to be dissipated via the heat leakage radiator circuit. Alternatively a second thermostat can be provided in the thermal store to activate the pump but this must be ordered with the store.

# HEATING SYSTEM DESIGN

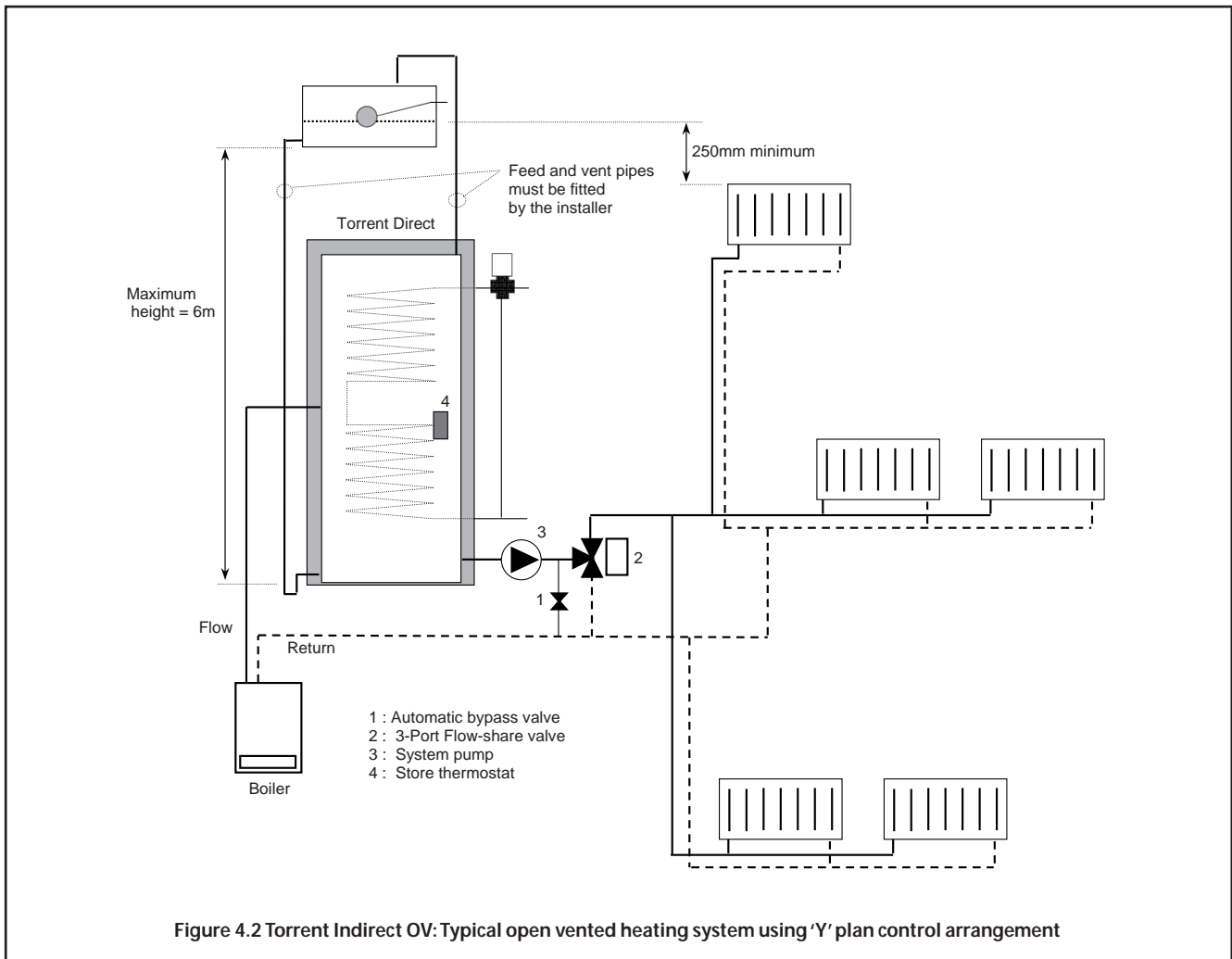
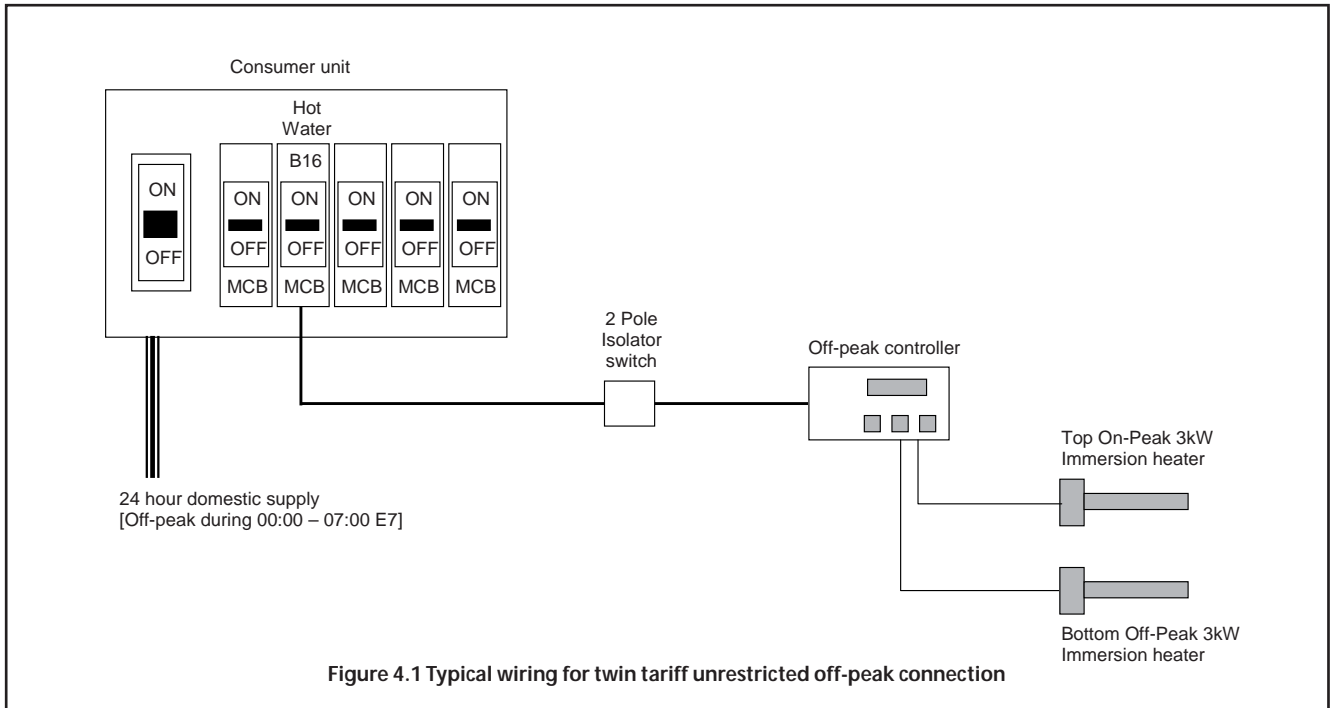

DIAGRAMS

# HEATING SYSTEM DESIGN

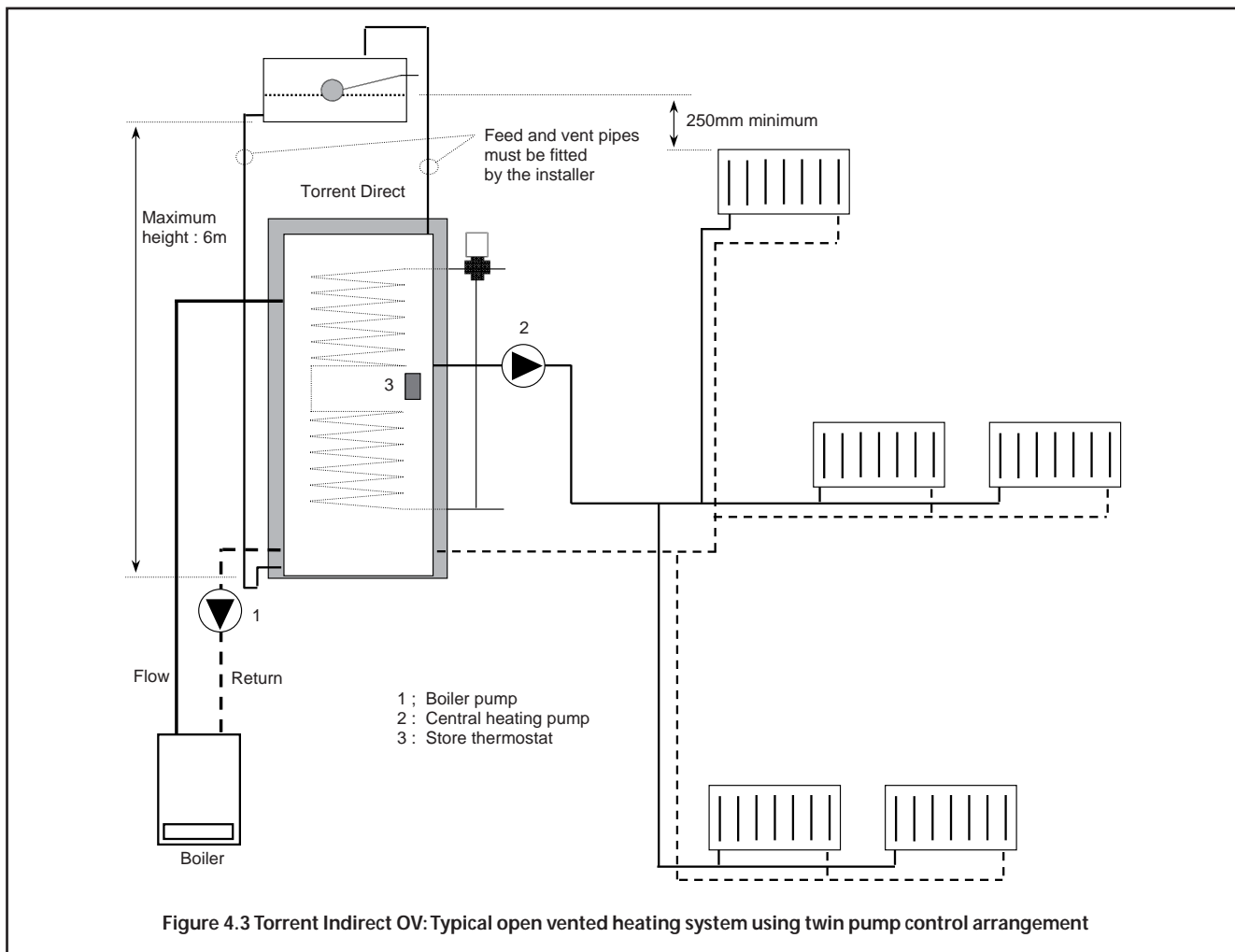

Figure 4.3 Torrent Indirect OV: Typical open vented heating system using twin pump control arrangement

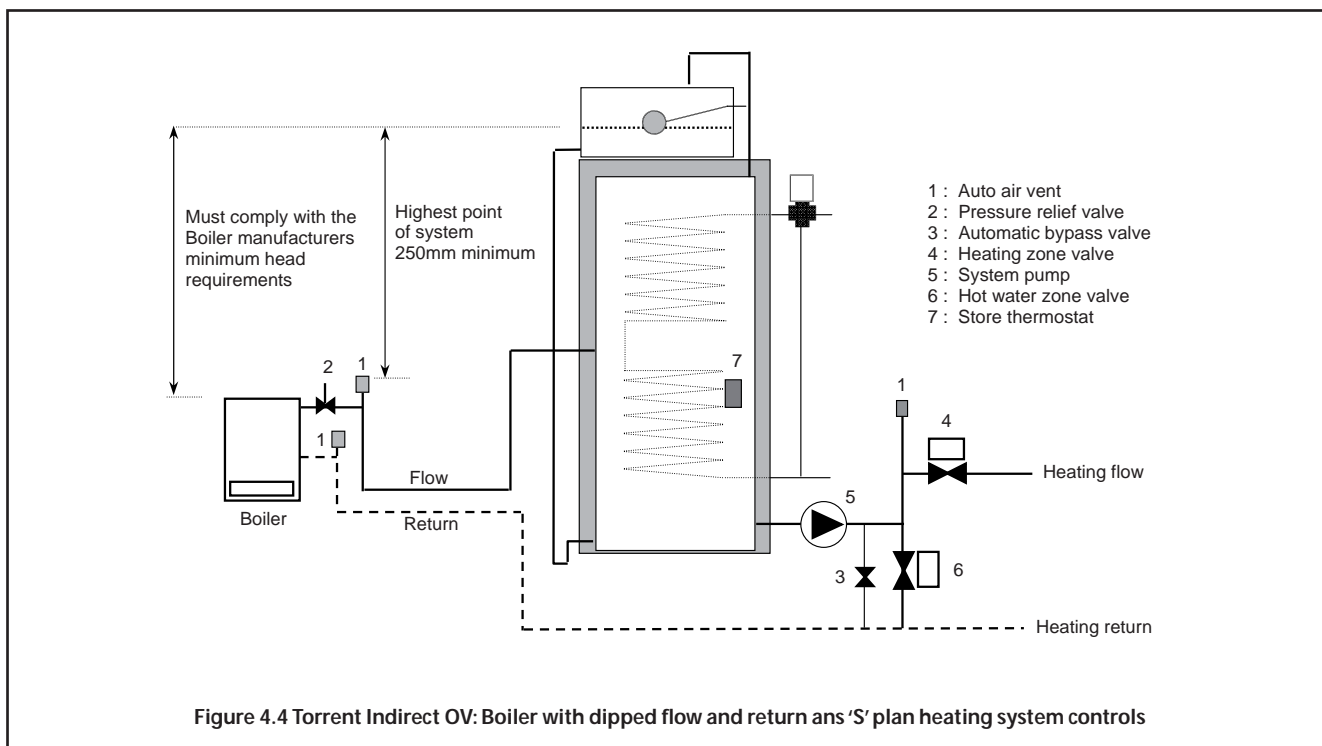
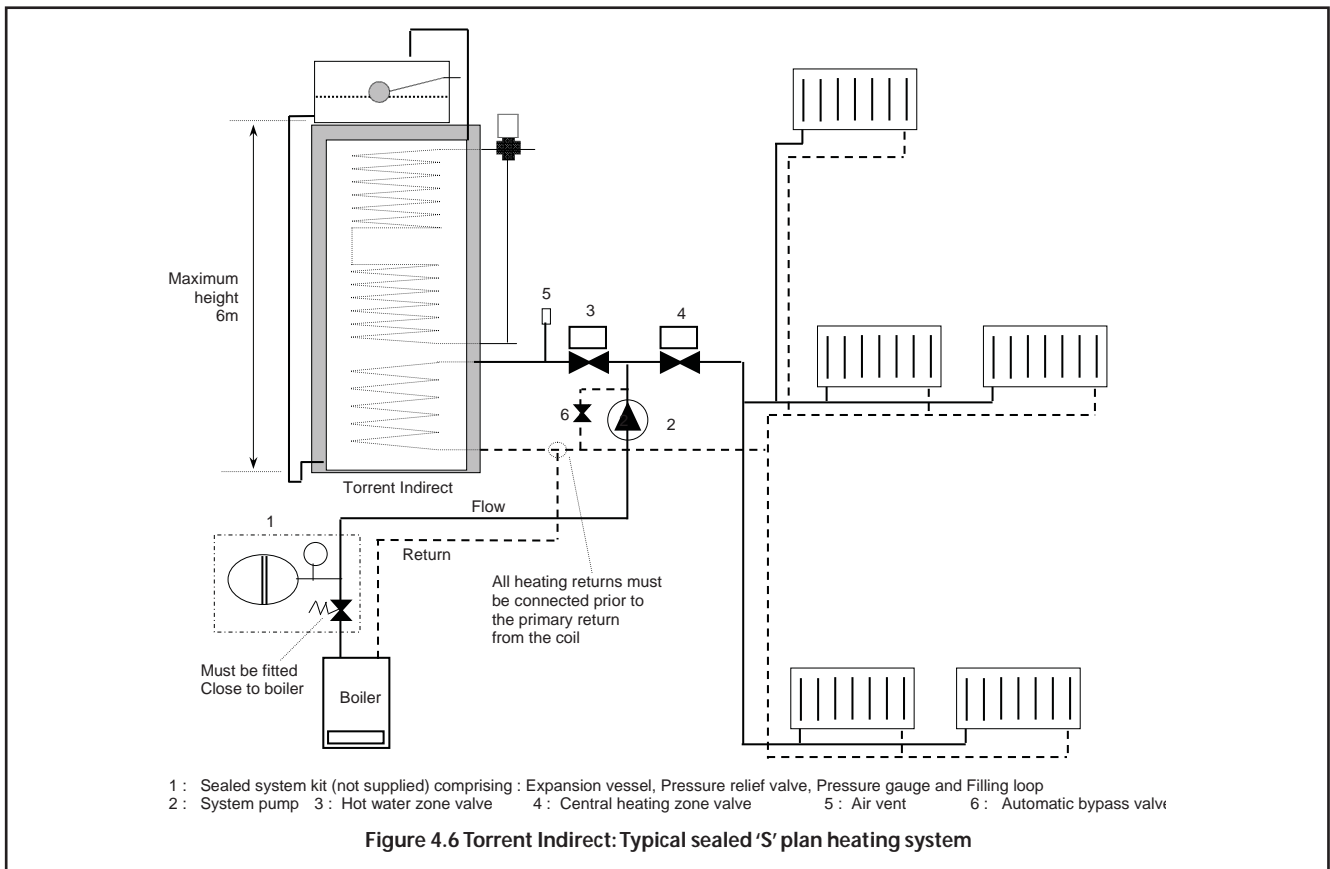
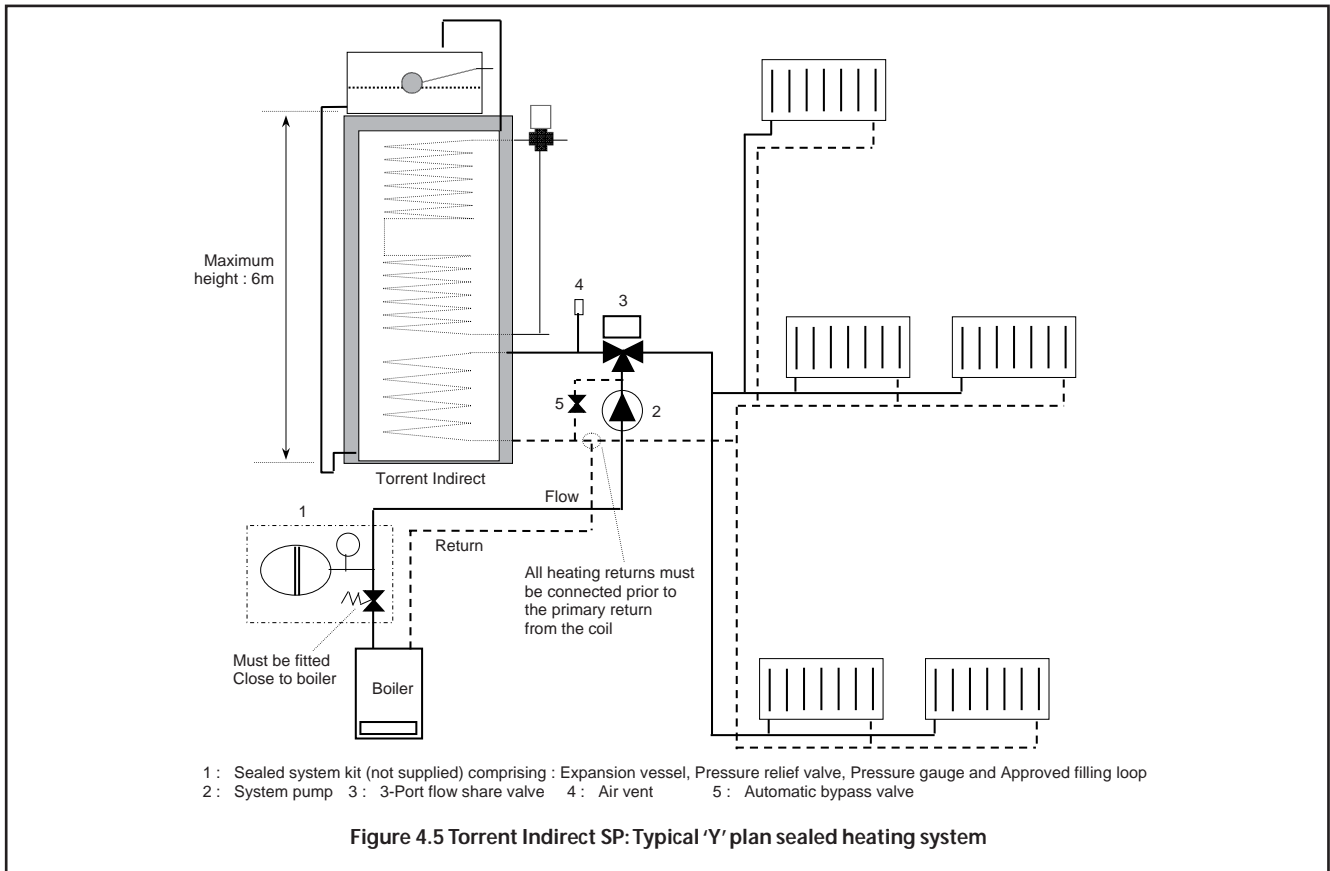

Figure 4.4 Torrent Indirect OV: Boiler with dipped flow and return and 'S' plan heating system controls

# HEATING SYSTEM DESIGN





# HEATING SYSTEM DESIGN

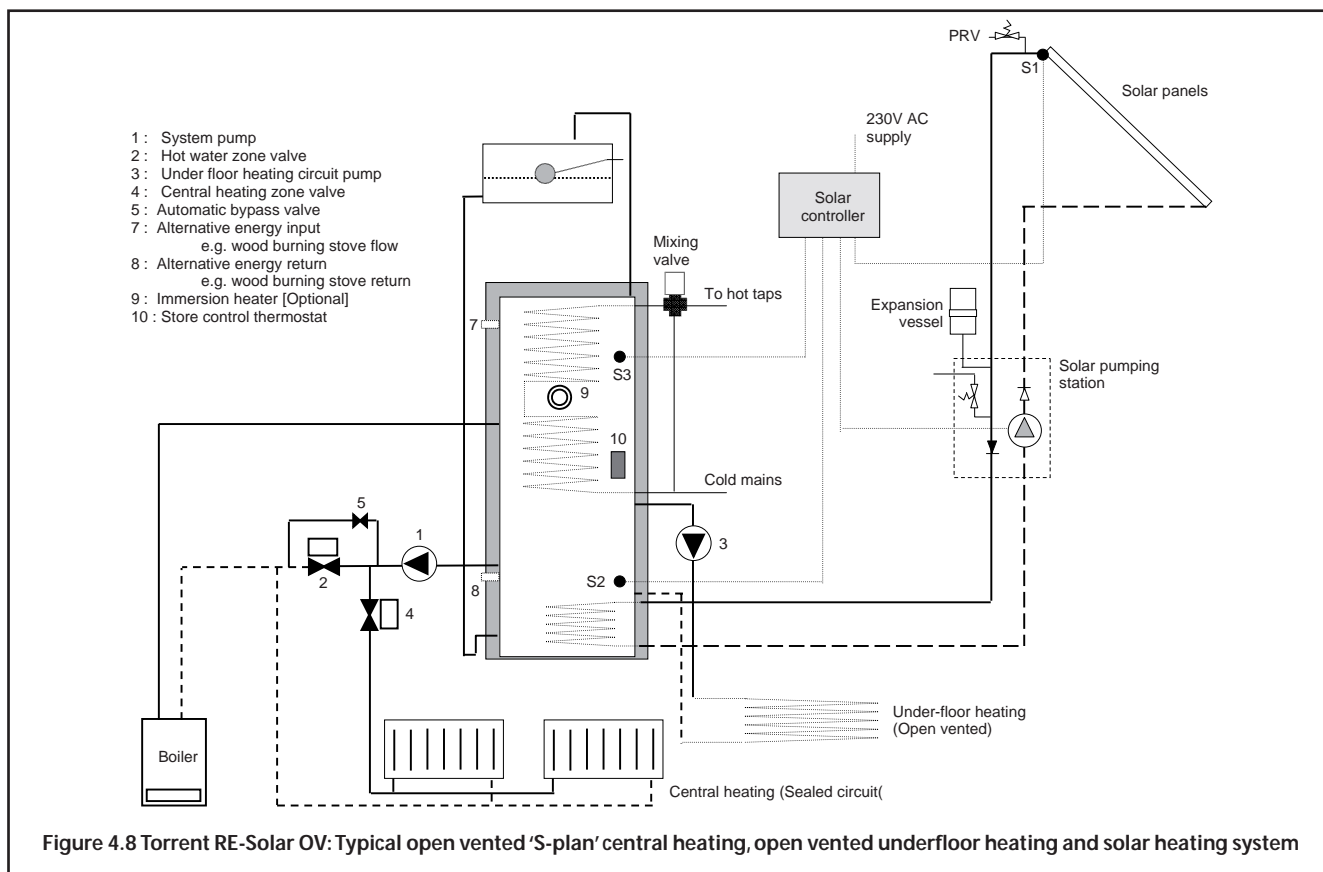
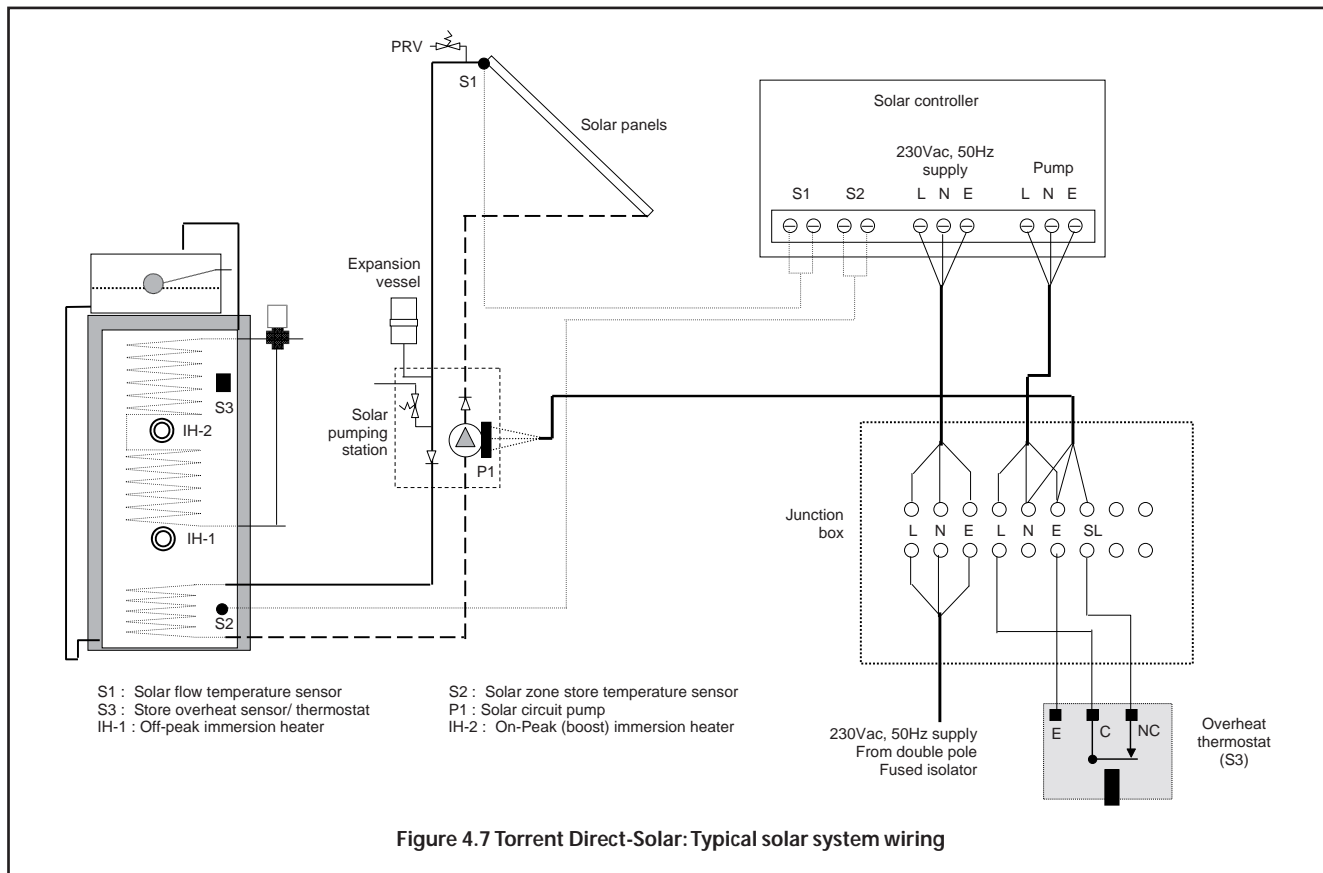



## 5.1 GENERAL ( FOR ALL TYPES AND MODELS )

- (a) All Torrent models are designed to be installed in an airing cupboard and the relevant minimum dimensions are given in technical data tables in section 2. The maintenance access is to the front and top of the appliance and this should be considered when positioning the appliance in the cupboard.

The floor of the cupboard needs to be level and even and capable of supporting the weight of the appliance when full (see technical data tables in section 2.0 or the data badge on the appliance).

- (b) The cupboard temperatures will normally be slightly higher than in a conventional system and the design of the cupboard and the door will need to be take this into account. No ventilation is normally required to the cupboard.
- (c) The appliance should be handled carefully to avoid damage. The recommended method is: -
- When lifting the unit work with someone of similar build and height if possible
  - Choose one person to call the signals.
  - Lift from the hips at the same time, then raise the unit to the desired level.
  - Move smoothly in unison.
  - Larger units may require a team lift.

Although the recommended method is provided below, any manual handling/lifting operations will need to comply with the requirements of the '*Manual Handling Operations Regulations*' issued by H.S.E. (See appendix B).

- (d) It is envisaged that the F&E cistern will be located in the same cupboard as the Torrent. However if it is necessary to locate the cistern in a roof space or on a higher floor then it must not be fitted more than 6m above the base of the Torrent. If the feed and expansion cistern is installed in a roof space (or unheated part of the dwelling), then any pipework and the feed and expansion cistern will need to be adequately insulated to protect against frost damage.

The F&E tank supplied will not be large enough for all stores/systems listed in the manual. It will be necessary to couple two together or replace with a larger tank in certain circumstances. We leave this to the installer to calculate because we do not know the capacities of multi-fuel boilers etc.

- (e) In all Torrent models (even when the heating system is sealed), the thermal store is open vented and therefore the installer must fit the feed and open vent pipes ensuring continuous rise on the open vent. Combined cold feed and vent pipe arrangements must not be used and no valves should be used in the safety open vent pipe which must be minimum of 22mm copper pipe or equivalent.
- (f) The overflow/warning pipe shall have a continuous fall, be fitted to discharge clear of the building and be sited so that any overflow can be easily observed. It shall also be installed in a size and material suitable for use with heating feed and expansion cisterns in accordance with BS 5449 and should not have any other connections to it.
- (g) The domestic hot water circuit contains its own expansion chamber within the thermal store but it is important not to have non-return valve down stream of the Torrent (store) so that there is a expansion route to a ball valve if needed (see figure 3.1, section 3).

# INSTALLATION

## 5.2 TORRENT DIRECT

- (a) The Torrent Direct is supplied with two 3kW immersion heaters and has been designed to generally operate with an off-peak supply. The lower immersion heater heats the whole of the store and is normally connected to the off-peak supply. The top immersion heater heats the top of the store and this is connected to the unrestricted on-peak supply and is switched manually by the householder when required using the off-peak controller.
- (b) The schematic arrangement of the wiring for the Torrent Direct is shown in figure 4.1. The whole of the electrical installation shall be designed and installed by a competent person fully in accordance with the latest edition of the *'Requirements for Electrical Installations'*,
- (c) It is important to ensure that the primary store is filled and vented before switching on the immersion heaters. Even if the water is available at the hot and cold taps, it does not necessarily follow that the store has water in it. Please check the feed and expansion cistern).

## 5.3 TORRENT INDIRECT and TORRENT RE-Solar

- (a) The design requirements for the open vented and sealed heating systems are described in section 4 of this document and the system should be installed according to these guide lines and the guidance notes supplied with other relevant heating equipment being installed.
- (b) If the optional immersion heater is fitted to the Torrent, then wiring to it must be in accordance with the relevant IEE Wiring regulations and the circuit must be protected by a suitable fuse and a double pole isolating switch.
- (c) Both Torrent Indirect and Torrent RE-Solar ('OV' and 'SP') models can be installed and wired using either 'Y' Plan, 'S' Plan control systems. Also the 'OV' models can be installed and wired using separate pumps for space heating and boiler circuits. The example wiring diagrams are included in this manual for guidance are listed below.
  - Figure 5.1 : Example wiring diagram for a 'Y' Plan heating system for the Torrent Indirect 'OV' and 'SP' models.
  - Figure 5.2 : Example wiring diagram for a 'S' Plan heating system for the Torrent Indirect 'OV' and 'SP' models.
  - Figure 5.3 : Example wiring diagram for a 'Y' Plan central heating system and typical solar heating system for the Torrent RE-solar 'OV' and 'SP' models.
  - Figure 5.4 : Example wiring diagram for a 'S' Plan central heating system and typical solar heating system for the Torrent RE-solar 'OV' and 'SP' models.
  - Figure 5.5 : Example wiring diagram for a 'Y' Plan central heating system and multi-fuel stove the Torrent RE-solar 'OV' and 'SP' models.
  - Figure 5.6 : Example wiring diagram for a 'S' Plan central heating system and multi-fuel stove the Torrent RE-solar 'OV' and 'SP' models.

The heating system electrical wiring shall be designed and installed by a competent person fully in accordance with the latest edition of the *'Requirements for Electrical Installations'*.

- (d) It is important to ensure that both the primary store and the system are filled and vented before switching on the boiler and the immersion heater (if fitted). Even if the water is available at the hot and cold taps, it does not necessarily follow that the store has water in it. Please check the feed and expansion cistern).

## 5.4 SOLAR HEATING SYSTEM ( Torrent RE-Solar and Torrent Direct-Solar )

- (a) The generic requirements for a solar heating system are described in sections 3.6. The installation of a solar thermal system should be in accordance with these guidelines and the system manufacturers instructions.
- (b) Typical generic solar system configurations are shown in figures 3.8 – 3.10 and generic controls and wiring diagrams are shown in figures 4.4 – 4.6 for guidance only. The solar heating system and the associated controls should be planned and installed following manufacturers instructions.
- (c) It is advisable that an overheat protection device is fitted to limit the store temperature exceeding 85°C from solar gains during stagnant conditions. A method of achieving this is shown in the appropriate wiring diagram.
- (d) It is advisable that a boiler hold-off device is fitted to maximise the utilisation of solar energy by limiting the unnecessary operation of the boiler. A method of achieving this is shown in the appropriate wiring diagram.

## 5.5 OTHER ALTERNATIVE ENERGY SOURCES (e.g. Wood burning stove)

- (a) The Torrent RE-Solar models have provision for connecting other alternative energy sources such as AGA or Wood burning stove in conjunction with a heat leak radiator system.
- (b) Although the thermal store is open vented and hence inherently safe, a heat leak system must be provided to prevent the possibility of boiling temperatures being reached in the thermal store.

This is normally achieved by providing a suitable pipe thermostat on the alternative energy heat source flow pipe which is set at approximately 85 – 90°C and wired so that when this temperature is reached, the heating pump/zone valve will operate to allow excess heat to be dissipated via the heat leakage radiator circuit. Alternatively a second thermostat can be provided in the thermal store to activate the pump but this must be ordered with the store.

- (c) Alternative energy source should be installed and piped so that it conforms to the manufacturers instructions.

# INSTALLATION

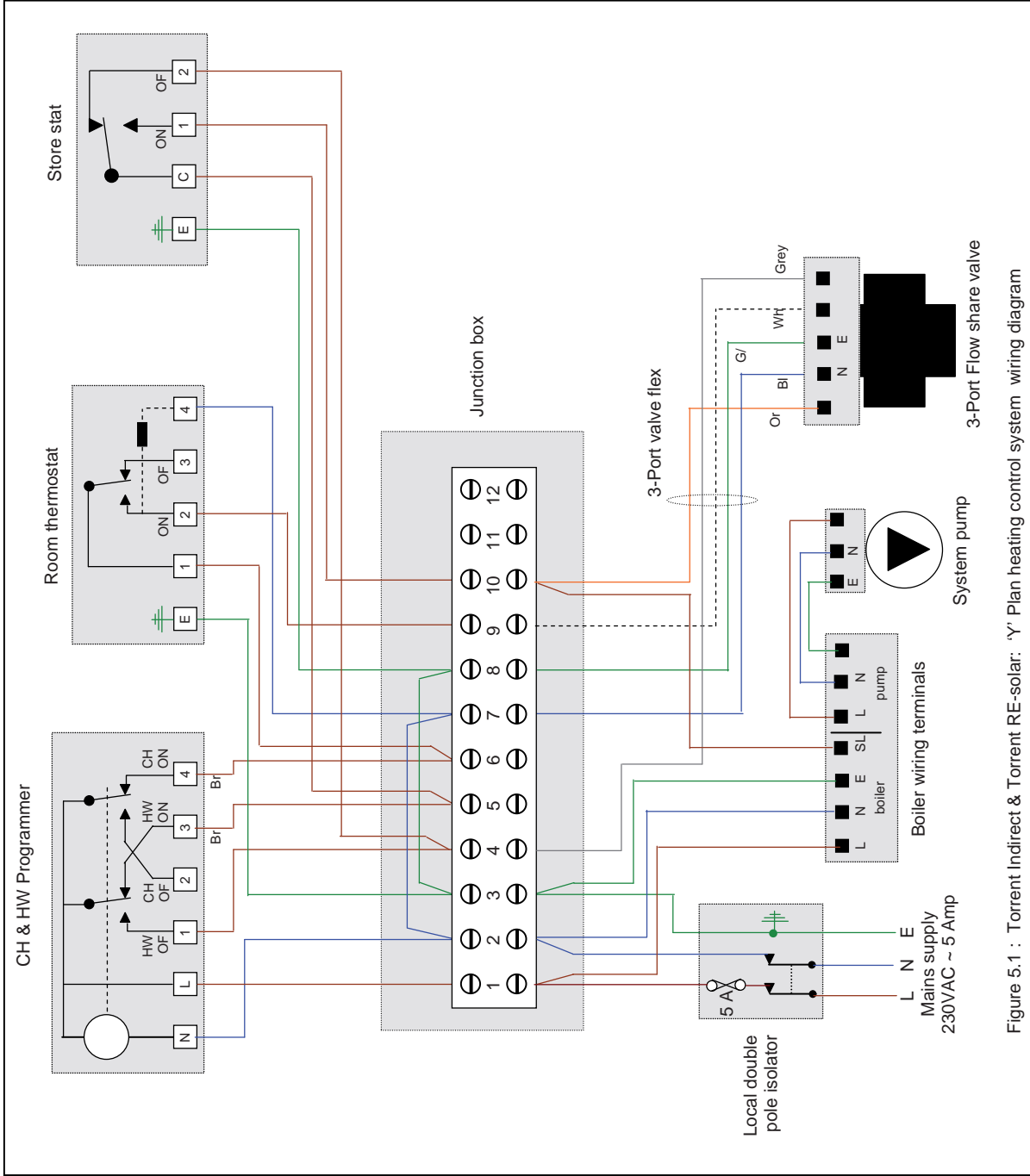

Figure 5.1 : Torrent Indirect & Torrent RE-solar: 'Y' Plan heating control system wiring diagram

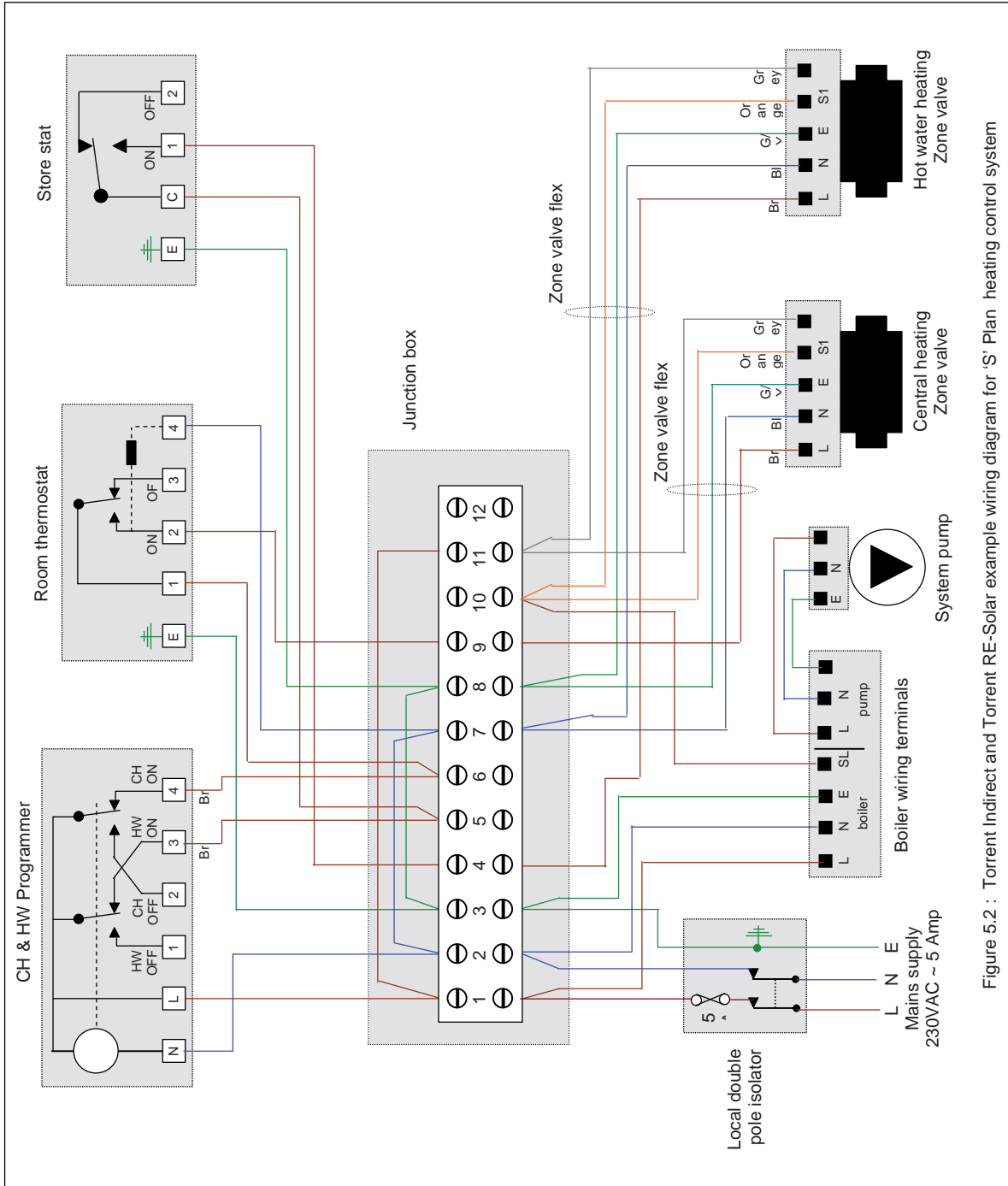

Figure 5.2 : Torrent Indirect and Torrent RE-Solar example wiring diagram for 'S' Plan heating control system

# INSTALLATION

## DIAGRAMS

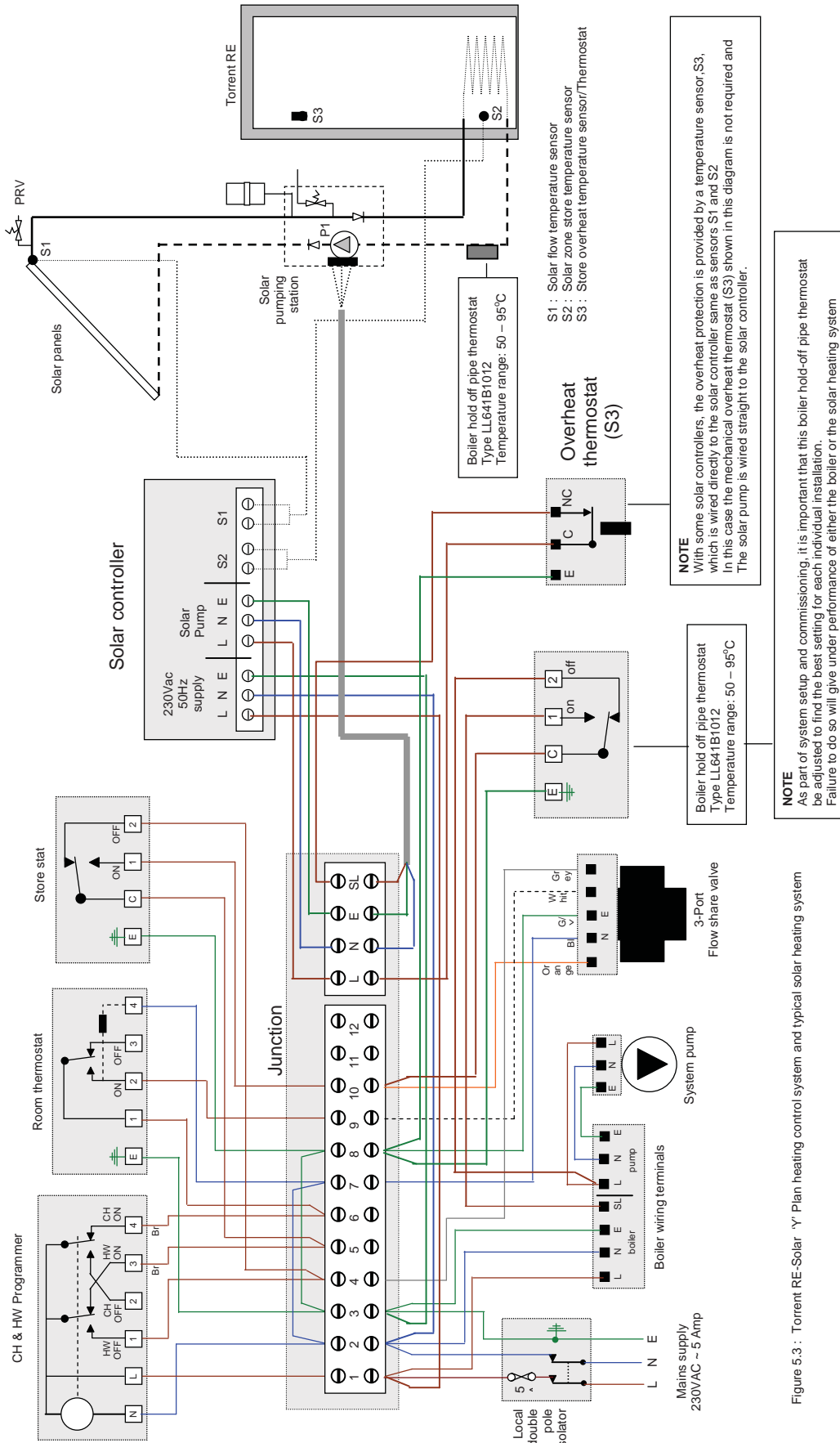

Figure 5.3 : Torrent RE-Solar Y Plan heating control system and typical solar heating system



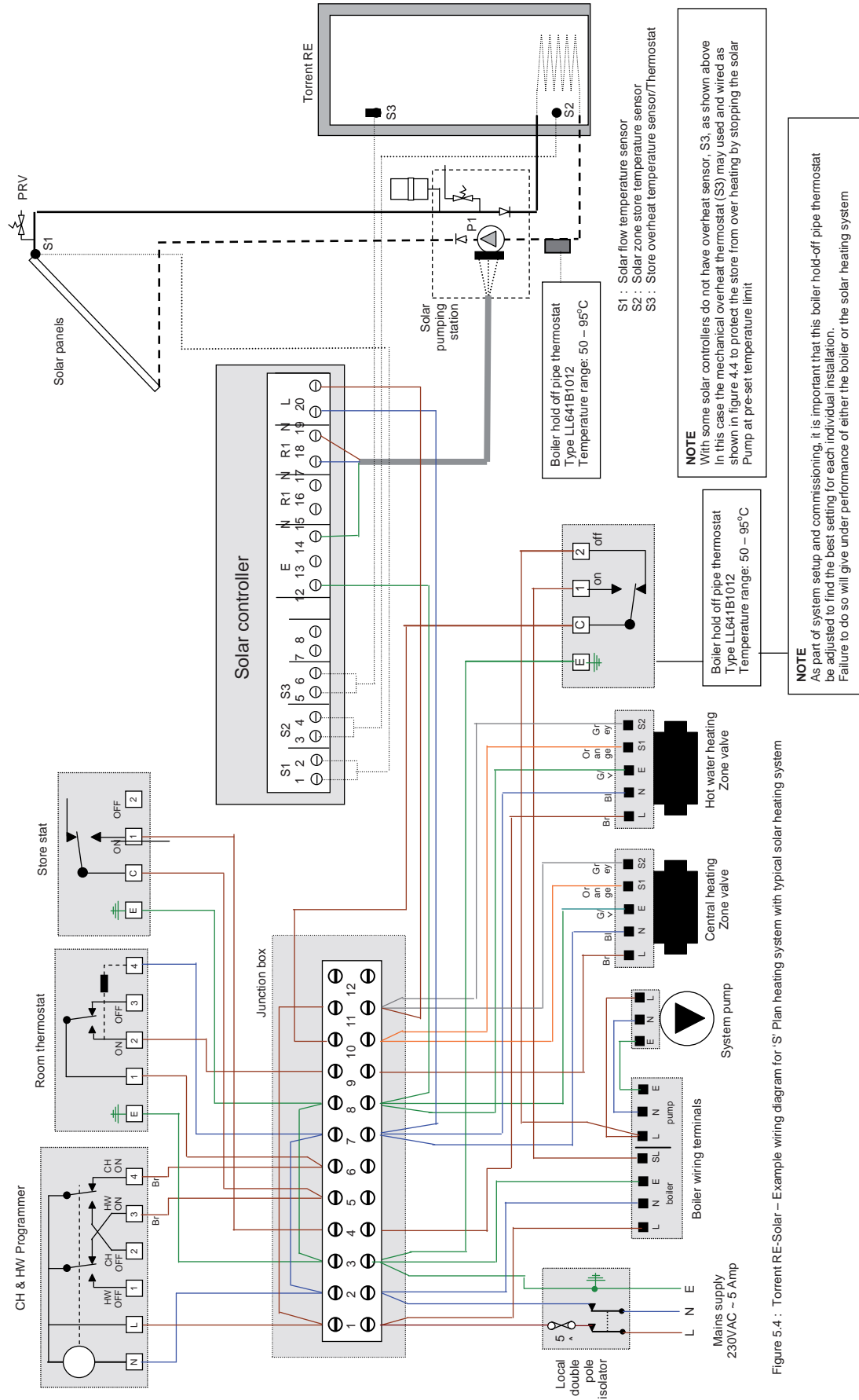
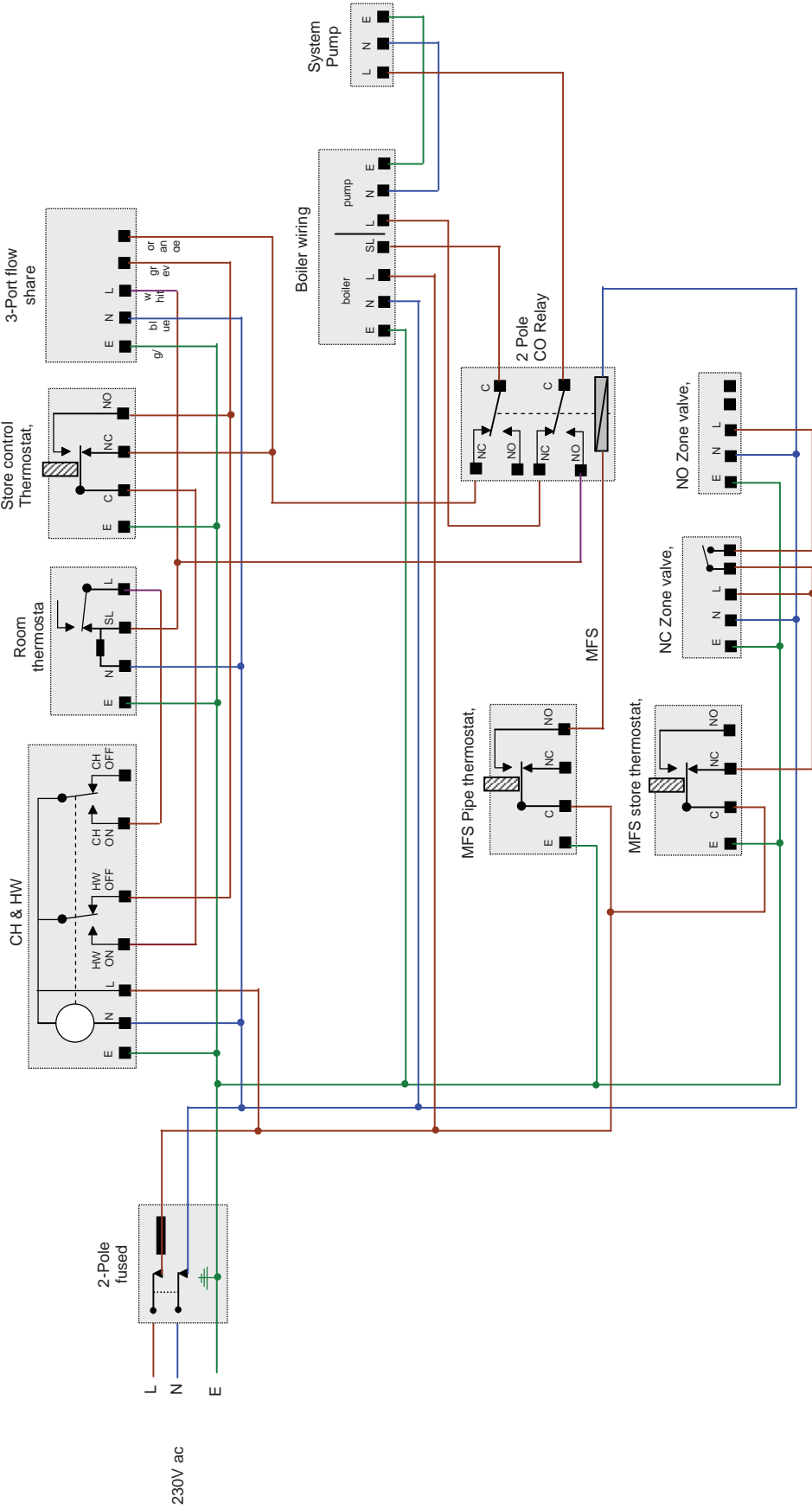

Figure 5.4 : Torrent RE-Solar – Example wiring diagram for 'S' Plan heating system with typical solar heating system

# INSTALLATION

## DIAGRAMS

Figure 5.5 Torrent RE Solar : Typical electrical wiring arrangement for a Multi Fuel Stove and 'Y' Plan central heating



**NOTES:**

- MFS thermostats (CT1 and CT2): NC= Contact breaks on temperature rise, NO = Contact makes on temperature rise
- Store control thermostat (CT3) : NC= Contact breaks on temperature rise, NO = Contact makes on temperature rise
- When CT1 is cold i.e. MFS is not operating: Central heating and domestic hot water heating demand supplied by an open vented gas/oil boiler and solar thermal system
- When CT1 is hot i.e. MFS is operating: thermal system Central heating and domestic hot water heating demand supplied by an open vented Multi Fuel Stove and solar thermal system
- Solar energy: To maximise utilisation of solar energy, the operation of the boiler can be held off by using the HW channel of the programmer.
- Solar energy: Solar system controls are not shown in this wiring arrangement
- The MFS pipe thermostat, CT1: It should be located close to the MFS on either flow or return pipe depending upon the system design and operating conditions
- The MFS pipe thermostat, CT1: It can be replaced with a single pole change over switch to select boiler or MFS as a heat source

Figure 5.6 Torrent RE - Solar : Typical electrical wiring arrangement for a Multi Fuel Stove and 'S' Plan central heating system

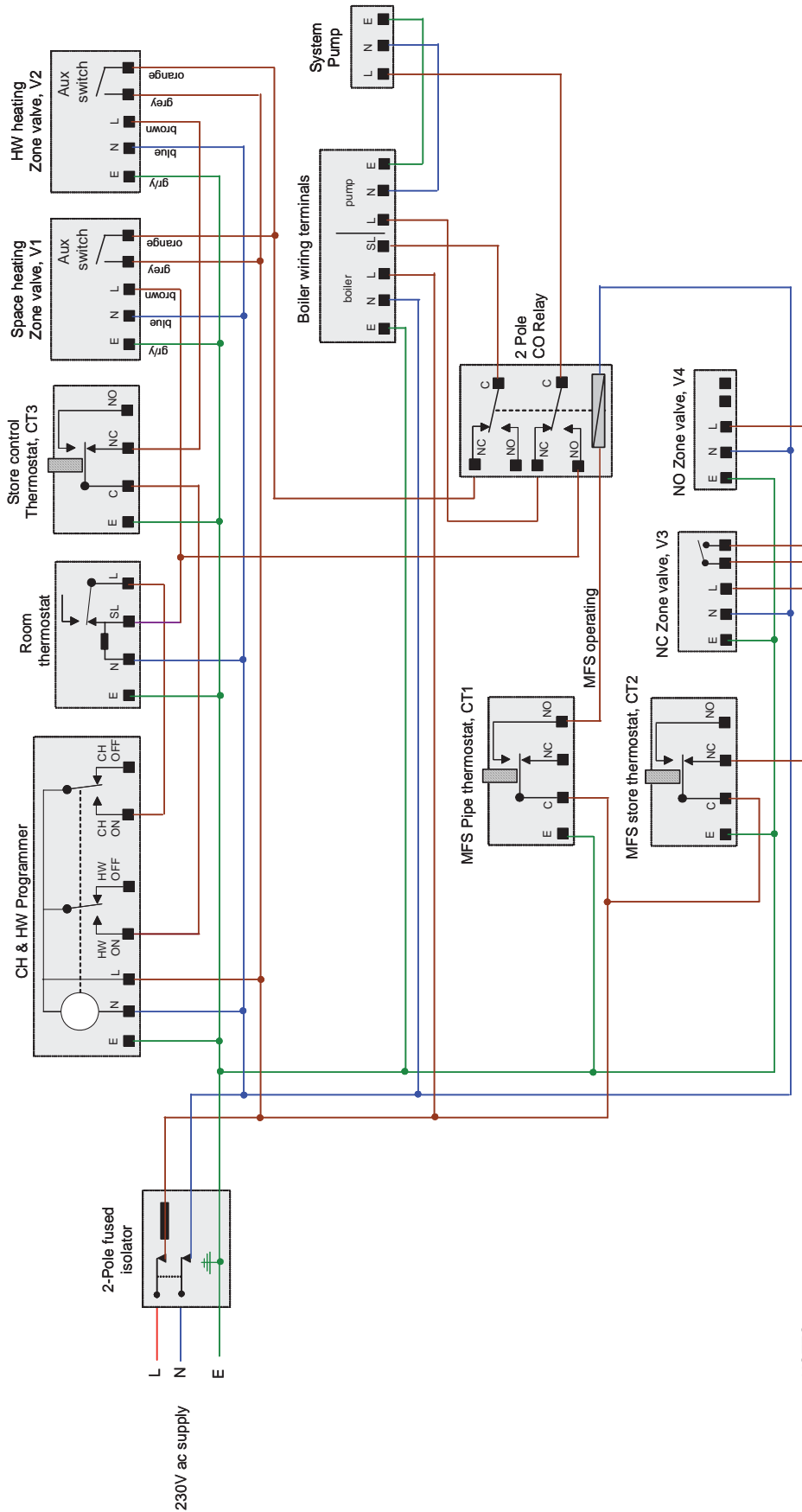

**NOTES:**

1. MFS thermostats (CT1 and CT2):
  2. Store control thermostat (CT3) :
  3. When CT1 is cold i.e. MFS is not operating:
  4. When CT1 is hot i.e. MFS is operating:
  5. Solar energy: To maximise utilisation of solar energy, the operation of the boiler can be held off by using the HW channel of the programmer.
  6. Solar energy: Solar system controls not shown in this wiring arrangement
  7. The MFS pipe thermostat, CT1: It should be located close to the MFS on either flow or return pipe depending upon the system design and operating conditions
  8. The MFS pipe thermostat, CT1: It can be replaced with a single pole change over switch to select boiler or MFS as a heat source
- NC= Contact breaks on temperature rise, NO = Contact makes on temperature rise  
 NC= Contact breaks on temperature rise, NO = Contact makes on temperature rise  
 Central heating and domestic hot water heating demand supplied by an open vented gas/oil boiler and solar thermal system  
 Central heating and domestic hot water heating demand supplied by an open vented Multi Fuel Stove and solar thermal system

# COMMISSIONING

## 6.1 TORRENT DIRECT MODELS

- (a) Ensure that the thermal store is filled with water to the water level mark inside the feed and expansion cistern and the ball valve (if fitted) is adjusted correctly.

If the ball valve is fitted turn down the service valve once the system is finally filled to the point where the warning/overflow pipe will cope with the discharge arising from a ball valve failure.

- (b) Switch the immersion heater on and allow the store to heat up to full temperature (typically 75 – 77°C).
- (c) When the store has been fully charged, open the nearest hot tap and check that the mixing valve at the Torrent unit is delivering the desired temperature of 55±5°C which is a factory set value. Adjust if necessary to suit individual requirements.
- (d) Instruct the occupant on how to use the off-peak timer (if fitted) and the appliance.
- (e) Fill in and sign the 'Benchmark' document and leave it and the appliance manual at suitable place near the appliance.
- (f) **Electrician/Installer:** *Please note that the water at the hot tap does not indicate that the Torrent is full. Check that there is water in the feed and expansion cistern before switching on the immersion heaters. Dry firing the elements will cause premature failure which is not covered by our warranty.*

## 6.2 NON-ELECTRIC TORRENT MODELS

- (a) Open the incoming stop valve and fill the domestic hot water system. For open vented heating system, fill the whole of the primary heating system and the thermal store with potable water through the feed and expansion cistern. For sealed heating system fill the thermal store with potable water through the feed and expansion cistern and the heating system to the design pressure using the filling loop.
- (b) Check the water level in the feed and expansion cistern and adjust the ball valve if necessary. Check the whole of the primary heating and domestic hot and cold distribution system, including the Torrent for leaks.
- (c) It is essential that all systems function properly for optimum performance and to achieve this:-
  - The primary system should be commissioned in accordance with good practice and generally in accordance with the requirements of BS 6798, BS 5449 and BS 7593. Full details of the requirements are given in PAS 33:1999 under section 10 Commissioning.
  - The boiler manufacturers instructions should be followed during the commissioning phase.
  - If solar thermal system is fitted it should be commissioned as per manufacturers instructions.

# COMMISSIONING

- When using either cleansing or corrosion inhibitor chemical, the manufactures instructions must be followed.
- (d) When determining the quantities for cleanser required, the volume of the Torrent should be added to the water content of the primary system. Although the Torrent has no special water treatment requirements, the radiators and other parts of the circuit will require the application of a scale and corrosion inhibitor.
- (e) If it is proposed to 'powerflush' the heating system we would recommend that the Torrent is isolated from the heating system being cleaned. Failure to do so could seriously damage the unit. If in doubt please contact our Technical Helpline on 01253 474584.
- Fill the system and flush cold and then refill and vent the system.
  - Add cleanser such as Fernox Superfloc or sentinel X300 to ensure that flux residues and the installation debris are removed from the system.
  - Ensure that the store thermostat is set at 75°C and the boiler thermostat is set at its maximum. Set the boiler/system pump to give temperature difference across the boiler between 8 – 15°C.
  - Switch on the system and to ensure full cleansing, circulation to all parts of the system should continue for a minimum of 1 hour.
  - Flush the system hot having checked that there is no overflow or leaks when the system is up to temperature.
  - Refill and vent the system and add appropriate amount of scale inhibitor, such as Fernox MB1 or Sentinel X100.
- (f) Set the boiler temperature to maximum and with the central heating off, let the system (i.e. store) heat up ( Approximately 1 – 2 hours). When the store is up to temperature (75 - 77°C): -
- open the nearest hot tap and check that the mixing valve at the Torrent unit is delivering the desired temperature of 55±5°C which is a factory set value. Adjust if necessary to suit individual requirements.
  - Check that the space heating system controls (e.g. programmer, room thermostat) are functioning correctly.
- (g) Switch off space heating system and ensure that the store thermostat is set to 70°C and the boiler thermostat is set to maximum.
- (h) Re-fire the boiler by running a little water and wait for the boiler to switch off. Check that there is no live supply from the store thermostat i.e. it is satisfied.

# COMMISSIONING

- DO - Check the incoming mains water pressure. If it exceeds 3.5 bar at any point in the 24 hour cycle then a pressure limiting valve set at 3.5 bar should be fitted where the cold supply enters the property.
- DO - Check that all connections are in accordance with the labelling on the thermal store.
- DO - Fill the cistern manually or adjust the ballvalve so that the water in the F & E cistern is set to the correct level.
- DO - Restrict the ballvalve fill rate when full so that the overflow pipe can cope with the fill rate in the event of a ballvalve failure.
- DO - Make sure there is adequate clearance above the F & E cistern to service the valve.
- DO - Ensure that range-rated appliances are set **to the specified design heat input and the boiler thermostat is set to maximum for all boilers.**
- DO - Ensure that the water level in the expansion cistern is at least 250mm above the highest point on the radiator circuit and satisfies the boiler head required.
- DO - Insulate any exposed pipework in the Torrent cupboard.
- DO - Plumb the overflow warning pipe in 20mm minimum internal diameter tubing to discharge in a conspicuous external position, using high temperature uPVC or copper.
- DO - Check the pump setting. This should be set as high as possible (consistent with not creating noise) so as to give a small temperature difference across the boiler, i.e. not greater than 11°C.
- DON'T - Use a combined feed and vent on Torrent indirect installations.
- DON'T - Use tube smaller than 28mm between boiler and Torrent when the boiler exceeds 60,000 Btu (17kW) output.
- DON'T - Use dipped flow and return pipes between boiler and Torrent unless the boiler is fitted with an overheat switch.
- DON'T - place any clothing or other combustible materials against or on top of this appliance.

In situations where scale inhibitors have not been fitted and the hot water service has deteriorated a Torrent can be descaled very easily with equipment available from Gledhill.

You can now do the whole job easily and efficiently on site - and do it under the hour.

The operation is carried by a VORTEX DECALOMAT-3 Descaling Unit which removes the scale chemically. By simply replacing the thermostatic mixing valve on the hot water outlet with the special adaptor valve supplied, descaling solution is pumped through the secondary coil (see figure 7). After approximately 45 minutes the job is done and the mixer valve is put back in place. The solution is made up of 2kg of either Sentinel ScaleClean or Fernox DS-3 descaling powder dissolved in 20 litres of water (preferably warm but not exceeding 70°C). The powders are manufactured with a colour indicator which changes as the active ingredients are used up.

### TO DESCALE TORRENT USING DECALOMAT-3

1. Before descaling turn the boiler off and run the hot water tap until the thermal store is below 40°C.
2. Turn off the mains water supply at stop tap supplying the Torrent.
3. Open a hot tap on the hot water system.
4. Break the three unions securing the Oventrop mixing valve to the Torrent and remove the Oventrop mixing valve making sure a container is in place to collect spillage.
5. Attach the adaptor to the Torrent - two unions and washers.
6. Close all hot taps on the DHW system.

### TO CHARGE DECALOMAT-3

7. Unscrew the large cap adjacent to the carrying handle.
8. Make sure that the hoses are connected together with the brass nipple.
9. Partly fill the Decalomat-3 with 20 litres of Sentinel ScaleClean solution or Fernox DS-3 solution (the solution should be 2kg of powder dissolved in water).

**Note: This solution is ACIDIC and MUST be handled with CARE. It is a wise precaution to do the mixing, filling and emptying outside the premises.**

Observe the manufacturers handling instructions.

10. Replace the filling cap on the Decalomat-3.
11. Break the joint between the hose (keeping both hoses above the level of the Decalomat-3) retaining the brass joining piece.
12. Attach the hoses to the adaptor (ensure that the unions are finger tight on the 3/4" BSP male connectors to the adaptor).
13. Loosen the filling cap on the Decalomat-3 to allow carbon dioxide formed in the descaling process to escape.
14. Plug the Decalomat-3 to a 240V 50Hz electric supply. The pump in the Decalomat will now circulate the coloured descaling solution through the heat exchanger coil of the Torrent. Depending on the degree of scale formation within the coil, the following may be observed:-

### WITH SENTINEL SCALECLEEN

1. The red solution will be observed in one of the transparent plastic tubes, foam and an orange/yellow liquid may be seen in the other tube.
2. Flow of the red liquid may initially be intermittent due to:
  - a. Gas formation in the coil as the Sentinel ScaleClean attacks the scale.
  - b. Degree of blockage - this stage may exist for about half an hour.
3. Continuous flow will begin with the red Sentinel ScaleClean solution in one pipe and a foaming solution in the other.
4. If after some time, the colour in both pipes has turned to yellow (no gas bubbles are observed), the Sentinel ScaleClean is now exhausted and requires changing.
5. When the solution in both tubes remains red or orange and no gas bubbles are observed, the coil has been descaled.

### WITH FERNOX DS-3

1. The yellow solution will be observed in one of the transparent plastic tubes, foam and a greenish blue liquid may be seen in the other tube.
2. Flow of the yellow liquid may initially be intermittent due to:
  - a. Gas formation in the coil as the Fernox DS-3 attacks the scale.
  - b. Degree of blockage - this stage may exist for about half an hour.
3. Continuous flow will begin with the yellow Fernox DS-3 solution in one pipe and a foaming solution in the other.
4. If after some time, the colour in both pipes has turned to green (no gas bubbles are observed), the Fernox DS-3 is now exhausted and requires changing.
5. When the solution in both tubes is still yellow and no gas bubbles are observed, the coil has been descaled.

### TO REMOVE DECALOMAT-3

1. Unplug Decalomat-3 from electrical supply.
2. Tighten the filling cap on the Decalomat 3.
3. Remove the two hoses from the adaptor.
4. Join the hoses with brass connector piece.
5. Remove adaptor.
6. Replace Oventrop mixing valve - **ensuring that it is the correct way round.**
7. Open a hot tap - preferably to a porcelain sink.
8. Turn on the mains water supply to Torrent.
9. Allow the system to flush via the open hot tap for some minutes, then flush out system at each hot tap.

# SERVICING

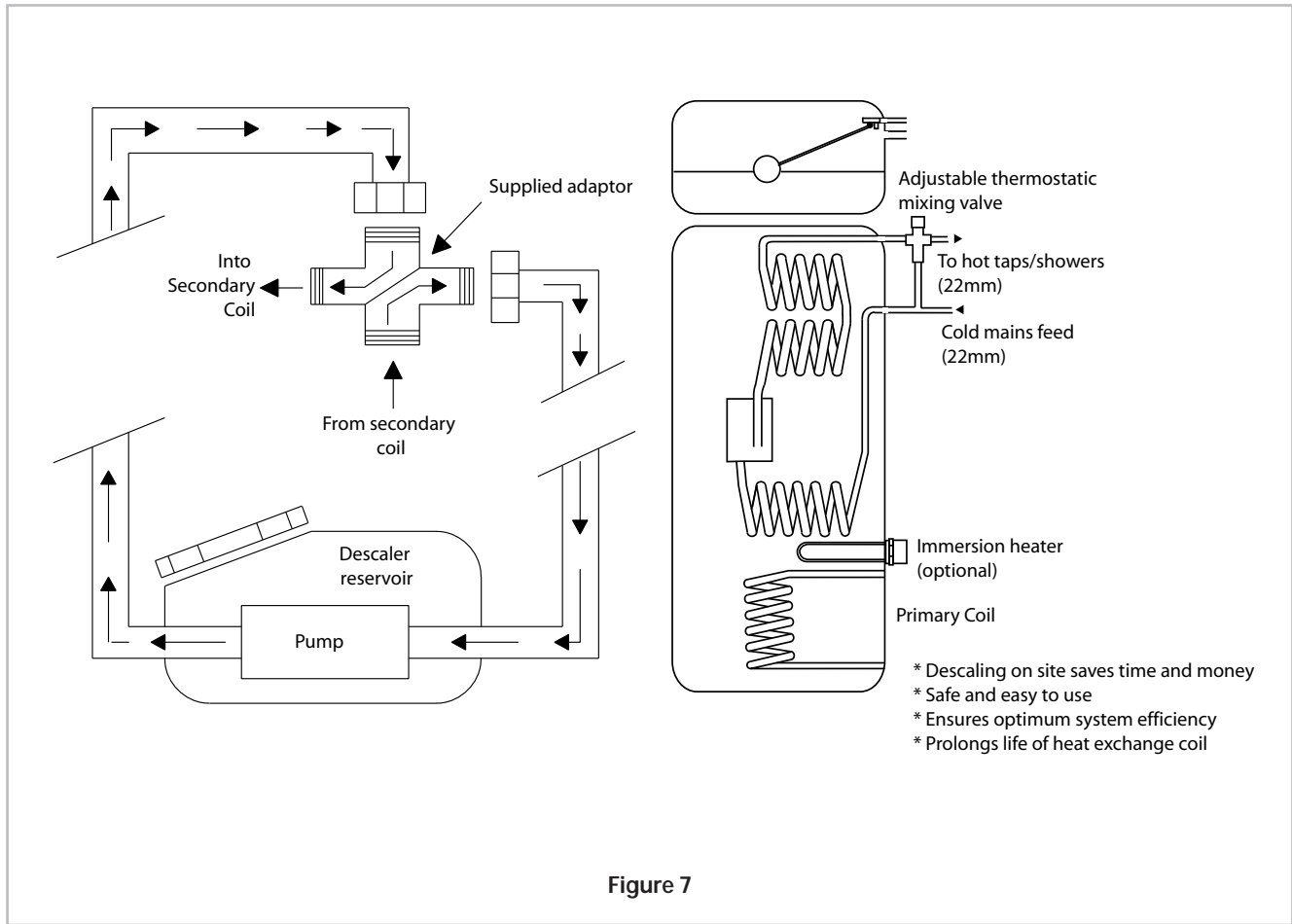

## ANNUAL SERVICING

No annual servicing of the Torrent is necessary.



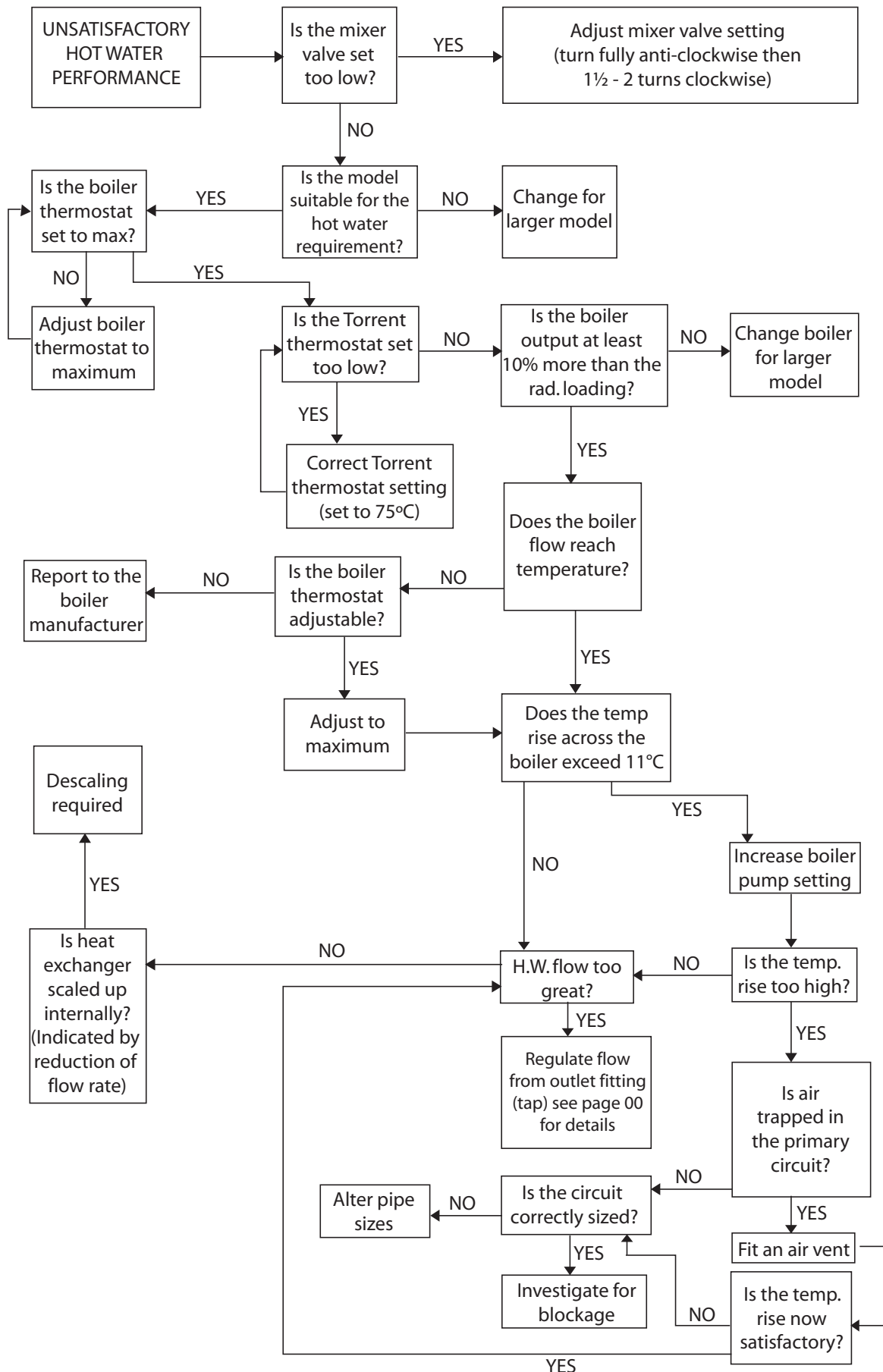

# SERVICING

Key No.	Description	Part No.	Gas Council Part No.
1	Ballvalve BS 1212 Part 2	FT207	370 505
2	Ballvalve Float	FT429	370 506
3	Mixing Valve - Brawa	XC007	385 872
4	Spare ring gasket for mixing valve	XC008	370 507
5	Immersion heater 3kW	XB078	E39 184
6	Control Thermostat	XC010	-
7			
8			
9			

## Water Savings

### Water Related Costs Can Be Reduced By Good Plumbing Practice

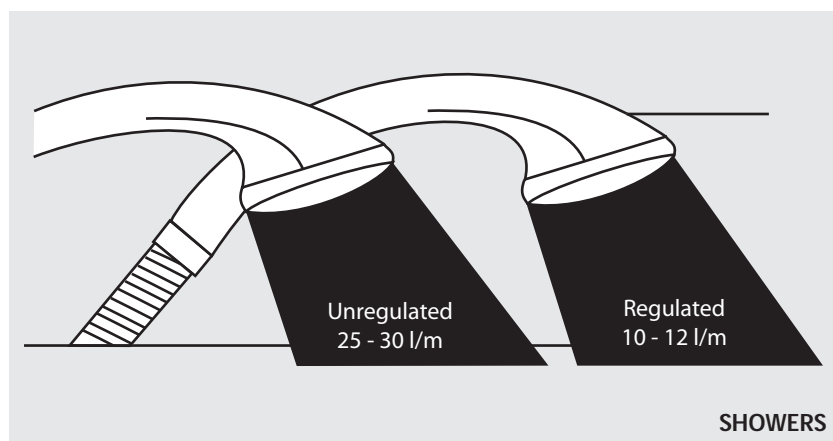
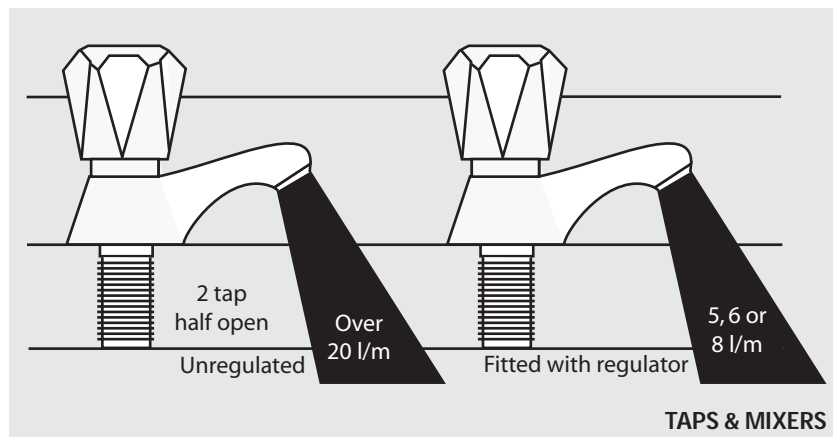

Vast quantities of water are needlessly run off to waste due to Taps, Mixers and Showers discharging flow rates far in excess of the rates required for them to perform their duties.

The contrasting flow rates shown on this leaflet clearly illustrate the savings that can be made whilst still providing a good performance.

British made Aquaflow Regulators provide constant flow rates by automatically compensating for supply pressure changes between 1 bar & 10 bars.

To facilitate installation into the wide range of plumbing equipment which is encountered in the U.K, Four Fixing Options are available:-

#### Options For Showers

1. MXF "DW" Range - For fitting behind Fixed Shower Heads or onto Flexible Hoses for Handshowers (preferably onto the inlet end when lightweight hoses are used).
2. Compression Fitting Range. "In Line" regulators as in Option 4 for Taps & Mixers.

Information by courtesy of  
**AQUAFLOW REGULATORS LTD**

Haywood House, 40 New Road, Stourbridge, West Midlands DY8 1PA  
TELEPHONE (01384) 442611 FAX: (01384) 442612

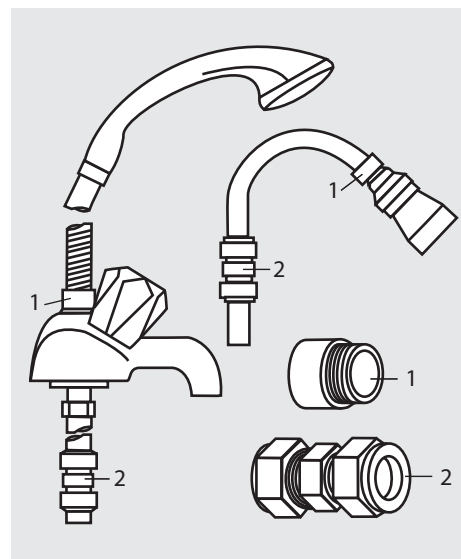

#### 4 Fixing Options For Taps & Mixers

1. MK Range - Combined Regulators & Aerator for screwing onto Taps & Mixers with internal or external threads on their noses. Anti Vandal models also available.
2. MR05-T Range - Internal Regulators. Push-fit into Tap or Mixer seats. Produced in three sizes - 12.5mm (BS1010), 12mm & 10mm, Flangeless models also available for Taps with Low Lift washers.
3. MXF Standard Range - Screw on tail models for Taps & Mixers. Fix onto the tails before fitting the tap connectors. Available in 3/8", 1/2", 3/4" and 1" BSP.
4. Compression Fitting Range - "In Line" regulators housed in 15mm & 22mm CXC Couplers & Isolating Valves. "δ" UKWFBs listed by the Water Research Centre. Isolation valves available for slotted screwdriver operation or with coloured plastic handles. Now available also in plastic bodied push-fit couplers & valves.

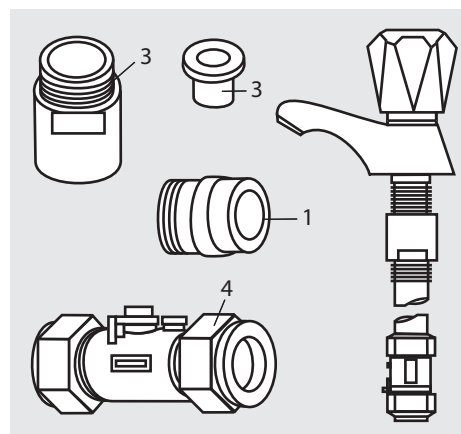

## MANUAL HANDLING OF APPLIANCE PRODUCTS

### Description

Manual handling means any transporting or supporting of a load (including lifting, putting down, pushing, pulling, carrying or moving) by hand or bodily force.

### Scope

This assessment will cover the largest unit within each product range manufactured by Gledhill.

For specific weights and dimensions please refer to technical data section.

### Main Hazards

Vision may not be clear due to the size of the products. Adopting an incorrect method of lifting may cause injury, attempting to lift these products will require help from others. (Team lifts)

### Control Measures

#### Manual lifting procedure

The lift, key factors in safe lifting are:

- a. **Balance**
- b. **Position of back**
- c. **Positioning of the arms and body**
- d. **The hold**
- e. **Taking the lead for team lifts**

- a. **Balance** - Since balance depends essentially upon the position of the feet, they should be apart about hip breadth with one foot advanced giving full balance sideways and forward without tension. In taking up this position, lifting is done by bending at the knees instead of the hips and the muscles that are brought into use are those of the thigh and not the back.
- b. **Position of back** - Straight - not necessary vertical. The spine must be kept rigid, this coupled with a bent knee position, allows the centre line of gravity of the body to be over the weight so reducing strain.
- c. **Positioning of arms and body** - The further arms are away from the side, the greater the strain on the shoulders, chest and back. Keep elbows close to the body arms should be straight.
- d. **The hold** - Before lifting ensure you have a good hold.

- e. **Taking the lead for team lifts**- As more than one person is required for these products ensure that one person is taking the lead. **This may be you** so ensure that each person that is helping is made aware of the weight and of the items listed within this assessment. Make sure you and any others helping know the route you intend to take that it is clear of any obstructions. Never jerk the load as this will add a little extra force and can cause severe strain to the arms, back and shoulders. If there are steps involved decide on where you will stop and take a rest period. Move smoothly and in unison taking care to look and listen to others helping with the lift. Where possible use a sack truck to move the product over long flat distances, only lift the products when necessary. If in doubt stop and get more help.

#### Individual capability

Individual capability plays an important part in handling these products. Persons above average build and strength will find it easier and should be in good health. Persons below average build and strength may require more rest periods during the handling process.

Pregnant women should not carry out this operation.

Persons who are not in good health should seek medical advice prior to commencing any lifting or manual handling operation.

#### Residual risk

Following the guidelines given above will reduce any risk to injury.

All persons carrying out this operation must be fully trained and copies of the specific risk assessment made available for inspection and use in their training process.

Further guidance on Manual Handling can be obtained from the Health and Safety Executive. Manual Handling Operations Regulations 1992.



## Product data

### PROTECTOR ALPHI-11

- Protects against corrosion and limescale
- Maintains efficiency so extending system life
- Prevents bacterial contamination
- Compatible with all metals and materials commonly used in heating systems
- Non-toxic, environmentally friendly
- Combined antifreeze and protector
- Protects heating, chilled water and solar systems

#### Product Uses

Fernox Protector Alphi-11 is a combined antifreeze and inhibitor, which gives long term protection of domestic central heating systems against internal corrosion and limescale formation. It prevents corrosion of all metals found in these systems, i.e. ferrous metals, copper and copper alloys and aluminium. It is especially recommended for use in solar systems. Fernox Protector Alphi-11 is compatible with all metals and materials commonly used in central heating systems.

For continued protection we recommend Protector levels are checked regularly (annually). The concentration of the product can be easily measured on site using a Fernox 'One Drop' Protector test kit.

#### Physical Properties

Fernox Protector Alphi-11 contains mono-propylene glycol.

Colour:	Colourless
Odour:	Mild
Form:	Clear liquid
pH (conc)	5.7 – 6.1
pH (soln 25%):	7.0 – 7.5
SG:	1.04 at 20°C

#### Application and Dosage

The minimum recommended "in-use" concentration of the product is 25% in order to ensure adequate corrosion protection. This concentration will protect down to -11°C. A concentration of 40% will protect down to -22°C. Alphi-11 Protector can be introduced via the feed and expansion tank or other suitable point of application, e.g. radiator, using a Fernox Injector. Introduce into the system after having drained a quantity of water at least equal to the amount of Alphi-11 to be added. Engage the circulating pump and have the system online for a few hours in order to achieve an even distribution.

Concentration	25%	30%	35%	40%
Protection	-11°C	-15°C	-18°C	-22°C

In single feed indirect cylinders, e.g. "Primatic" or similar, potable water chemicals must be used.

We recommend untreated systems are thoroughly cleansed and flushed, in accordance with BS7593 and Benchmark, using Fernox Cleaner F3 before treating with Fernox Alphi-11 Protector as existing debris can damage the installation.



Cookson Electronics, Forsyth Road, Sheerwater, Woking, Surrey, GU21 5RZ  
 Tel: +44 (0) 1483 793200 Fax: +44 (0) 1483 793201 Technical: +44 (0) 870 870 0362  
 email: sales@fernox.com www.fernox.com

Cookson Electronics is a trading name of Alpha Pty Ltd. A Cookson Company. Registered in London No: 3261715. VAT No: GB 258 1786 02



# Gledhill (Building Products) Ltd

AMD.OCTOBER 2011

## CONDITIONS OF SALE & GUARANTEE TERMS

1. Gledhill (Building Products) Ltd ("We" or "Gledhills") only do business upon the Conditions which appear below and no other. Unless we so agree in writing these Conditions shall apply in full to any supply of goods by us to the exclusion of any Conditions or terms sought to be imposed by any purchaser. These Conditions of Sale and Warranty Terms override those which are contained on the Invoice Forms and all Sales are now subject to these Conditions of Sale and Warranty terms only.

### 2. PRICE

Once an order or call off has been accepted the price will be held for three months **but if delivery is extended beyond that period at the customer's request, then we reserve the right to amend the price when necessary.** The company reviews its pricing annually to adjust for changes in our cost base. We reserve the right to alter prices at any time for severe movements in raw materials (mainly copper and steel). If there is to be a change we will give customers at least four weeks notice but anything delivered after that date will be at the revised price. An order may not be cancelled or varied after acceptance without the written consent of the company. Such cancellation or variation shall be subject to such reasonable charges as may be appropriate.

### 3. SPECIFICATION

The goods are supplied in accordance with the Specifications (if any) submitted to the Purchaser and any additions and alterations shall be the subject of an extra charge. Any goods not so specified shall be in accordance with our printed literature or the literature of any of our component suppliers (subject to any modifications made since publication). If we adopt any changes in construction or design of the goods, or in the specification printed in our literature, the Purchaser shall accept the goods so changed in fulfilment of the order.

### 4. PAYMENT

The buyer shall make payment in full within thirty days from the end of the month in which the invoice is dated. If we receive payment in full on or before the due date we will allow an appropriate settlement discount except where we have quoted a special net price. If payment is not received in full on or before the due date we shall be entitled in addition to the invoice price to:

- (i) payment of a sum equal to any increase in the copper price supplement applicable to the particular goods sold between the date of receipt of order and the date of receipt of payment in full; and
- (ii) interest on any part of the invoice price unpaid after the due date at the rate of 3% per annum over the base rate for the time being of HSBC Bank plc.

### 5. TIME

We give estimates of delivery dates in good faith and time of delivery is not nor shall be made of the essence of any contract nor shall we be liable for any loss or damage occasioned by delay in delivery.

### 6. DELIVERY

We deliver free normally by our own vehicles within 25 miles of any of our manufacturing depots. Delivery to any place more than 25 miles from one of our manufacturing depots may be subject to our quoted delivery charges. We reserve the right to make delivery of goods contained in one order by more than one consignment and at different times. Where a period is agreed for delivery and such period is not extended by our Agreement, the Purchaser shall take delivery within that period. If the Purchaser fails to take delivery, we shall be entitled at the Purchaser's risk and expense to store the goods at the Purchaser's premises or elsewhere and to demand payment as if they had been despatched. Off loading at point of delivery shall be the responsibility of and be undertaken by the Purchaser.

### 7. SHORTAGES OR DAMAGE

Goods must be inspected before signature of delivery note and any damage, shortage or discrepancy noted on the delivery note and the goods returned on the same vehicle. The buyer must also give us immediate written notice of the damage, shortage or discrepancy so that we may prompt investigation.

### 8. RETURN OF GOODS

Goods may not be returned to the Company except by prior written permission of an authorised officer of the Company and such return shall be subject to payment by the Purchaser of handling and re-stocking charges, transport and all other costs incurred by the Company.

### 9. COMPANY LIABILITY AND GUARANTEE

9.1. Subject to the terms of these Conditions of Sale and Guarantee Terms Gledhills provide Guarantees in respect of specific products as set out in this clause.

9.2. Each Guarantee is strictly conditional upon the following:-

9.2.1. Complaints must be given to us immediately, before any action is taken, as responsibility cannot be accepted if repairs or renewals are attempted on site without our written approval.

9.2.2. The unit has been installed in accordance with our installation and service instructions and all relevant codes of practice and regulations in force at the time of installation.

9.2.3. All necessary inlet controls and safety valves have been fitted correctly.

9.2.4. The unit has only been used for the storage of potable water supplied from the public mains.

9.2.5. Where appropriate the unit has been regularly maintained as detailed in the installation and service instructions

9.2.6. Defects caused by corrosion or scale deposits are not covered by any Guarantee.

9.2.7. Where we agree to rectify any defect we reserve the right to undertake the work on our own premises.

9.2.8. We will not accept any labour charges associated with replacing the unit or parts for any of the following products listed.

9.3. Guarantees are provided in respect of specified goods supplied by Gledhills as follows:-

#### (a) Domestic and Commercial Open Vented Cylinders and Tanks.

The storage vessel is guaranteed for ten years and if it proves to be defective either in materials or workmanship, we will either repair or supply replacement at our option with the closest substitute in the case of any obsolete product to any address in Great Britain.

(i) free of all charge during the first year after delivery by us.

(ii) thereafter at a charge of one-tenth of the then current list price and any copper price supplement and delivery charge during the second year after delivery by us and increasing by a further one-tenth on the second and subsequent anniversary of delivery by us.

#### (b) Domestic Mains Fed Products [Primary Stores]

The storage vessel is guaranteed for five years and if it or any integral pipework as part of the storage vessel assembly proves to be defective either in materials or workmanship, we reserve the right to either repair or supply replacements or the closest possible substitute in the case of any obsolete product and will collect and deliver to any address in England, Wales and Scotland (excluding all Scottish Islands).

(i) free of all charge during the first year after delivery by us.

(ii) thereafter at a charge of one-fifth of the then current list price or any copper price supplement and delivery charge during the second year after delivery by us increasing by a further one-fifth on the second and subsequent anniversary of delivery by us.

### (c) Stainless Steel Unvented Cylinders

Gledhill guarantee the components including controls, valves and electrical parts for two years from the date of purchase. IT SHOULD BE NOTED THAT THE FACTORY FITTED TEMPERATURE AND PRESSURE RELIEF VALVE MUST NOT BE REMOVED OR ALTERED IN ANY WAY OR THE GUARANTEE WILL NOT BE VALID. GLEDHILL WILL NOT BE RESPONSIBLE FOR ANY CONSEQUENTIAL LOSS OR DAMAGE HOWEVER IT IS CAUSED.

The guarantee for the stainless steel vessel is for twenty five years if the original unit is returned to us **AND PROVIDED THAT:**

- (i) It has not been modified, other than by Gledhill.
- (ii) It has not been subjected to wrong or improper use or left uncared for.
- (iii) It has only been used for the storage of potable water, max 200mg/litre chloride.
- (iv) It has not been subjected to frost damage.
- (v) The benchmark service record is completed after each annual service.
- (vi) The unit has been serviced annually.
- (vii) Any disinfection has been carried out strictly in accordance with BS6700.

If the stainless steel vessel proves to be defective either in materials or workmanship we reserve the right to either repair or supply replacements or the closest possible substitute in the case of any obsolete product and will collect and deliver to any address in England, Scotland and Wales (excluding all islands):

- (i) free of charge during the first year after delivery by us.
- (ii) thereafter at a charge of one twenty fifth of the then current list price during the second year after delivery by us and increasing by a further one twenty fifth on the second and subsequent anniversary of delivery by us.

### ACTION IN THE EVENT OF FAILURE

If the stainless steel cylinder develops a leak we will ask for a deposit against the supply of a new one. This will be refunded if the failure is within the terms of the warranty when it has been examined by us.

### **Please note:**

- Installation must have been carried out by a licensed specialized company (heating contractor or plumber) following the version of installation instructions in force.
- Gledhill or its representative was given the opportunity to check complaints on site immediately after any defect occurred.
- Confirmation exists that the system was commissioned properly and that the system was checked and maintenance was performed annually by a specialised company licensed for this purpose.

### (d) Components of our products other than Storage Vessels and Integral Pipework.

We will either extend to the purchaser the same terms of warranty as we are given by the manufacturer of the component or if the manufacturer does not give any warranty, replace free of charge any component which becomes defective within two years after the date of the delivery by us and is returned to us at the purchaser's expense but we shall not meet the cost of removal or shipping or return of the component or any other cost charges or damages incurred by the purchaser.

9.4.

9.4.1. In respect of goods supplied by us and in respect of any installation work carried out by or on our behalf, our entire liability and the purchaser's sole remedies (subject to the Guarantees) shall be as follows:-

- (a) We accept liability for death or personal injury to the extent that it results from our negligence or that of our employees
- (b) Subject to the other provisions of this clause 9 we accept liability for direct physical damage to tangible property to the extent that such damage is caused by our negligence or that of our employees, agents or subcontractors.

- (c) Our total liability to the purchaser over and above any liability to replace under the Guarantees (whether in contract or in tort including negligence) in respect of any one cause of loss or damage claimed to result from any breach of our obligations hereunder, shall be limited to actual money damages which shall not exceed £20,000 provided that such monetary limit shall not apply to any liability on the part of ourselves referred to in paragraph (a) above
- (d) Except as provided in paragraph (a) above but otherwise notwithstanding any provision herein contained in no event shall we be liable for the following loss or damage howsoever caused and even if foreseeable by us or in our contemplation:-
  - (i) economic loss which shall include loss of profits, business revenue, goodwill or anticipated savings
  - (ii) damages in respect of special indirect or consequential loss or damage (other than death, personal injury and damage to tangible property)
  - (iii) any claim made against the purchaser by any other party (save as expressly provided in paragraph (b) above)
- (e) Except in respect of our liability referred to in paragraph (a) above no claim may be made or action brought (whether in contract or in tort including negligence) by the purchaser in respect of any goods supplied by us more than one year after the date of the invoice for the relevant goods.
- (f) Without prejudice to any other term we shall not be liable for any water damage caused directly or indirectly as a result of any leak or other defect in the goods. We cannot control the conditions of use of the goods or the time or manner or location in which they will be installed and the purchaser agrees to be fully responsible for testing and checking all works which include the goods at all relevant times (up to, including and after commissioning) and for taking all necessary steps to identify any leaks and prevent any damage being caused thereby.
- (g) Nothing in these Conditions shall confer on the purchaser any rights or remedies to which the purchaser would not otherwise be legally entitled

#### 10. LOSS OR INJURY

Notwithstanding any other provision contained herein the purchaser's hereby agree to fully indemnify us against any damages losses costs claims or expenses incurred by us in respect of any claim brought against us by any third party for:-

- (a) any loss injury or damage wholly or partly caused by any goods supplied by us or their use.
- (b) any loss injury or damage wholly or partly caused by the defective installation or substandard workmanship or materials used in the installation of any goods supplied by us.
- (c) any loss injury or damage in any way connected with the performance of this contract.
- (d) any loss resulting from any failure by the purchaser to comply with its obligations under these terms as to install and/or check works correctly.

**PROVIDED** that this paragraph will not require the purchaser to indemnify us against any liability for our own acts of negligence or those of our employees agents or sub-contractors

**FURTHER** in the case of goods supplied by us which are re-sold and installed by a third party by the purchaser it will be the sole responsibility of the purchaser to test the goods immediately after their installation to ensure that inter alia they are correctly installed and in proper working order free from leaks and are not likely to cause any loss injury or damage to any person or property.

#### 11. VARIATION OF WARRANTY AND EXCLUSION

Should our warranty and exclusion be unacceptable we are prepared to negotiate for variation in their terms but only on the basis of an increase in the price to allow for any additional liability or risk which may result from the variation. Purchasers are advised to insure against any risk or liability which they may incur and which is not covered by our warranty.

#### 12. ADVICE

Any advice or assistance given by the Company is provided without charge and is in good faith without undertaking, representation or warranty, and we will not accept any liability, whether consequential or compensatory, for advice or assistance given.

#### 13. RISK AND RETENTION OF TITLE

- (a) goods supplied by us shall be at the Purchaser's risk immediately upon delivery to the Purchaser or into custody on the Purchaser's behalf or to the Purchaser's Order. The Purchaser shall effect adequate insurance of the goods against all risks to the full invoice value of the goods, such insurance to be effective from the time of delivery until property in the goods shall pass to the Purchaser as hereinafter provided.
- (b) property in the goods supplied hereunder will pass to the Purchaser when full payment has been made by the Purchaser to us for :-
  - (i) the goods of the subject of this contract.
  - (ii) all other goods the subject to of any other contract between the Purchaser and us which, at the time of payment of the full price of the goods sold under this contract, have been delivered to the Purchaser but not paid for in full.
- (c) until property in the goods supplied hereunder passes to the Purchaser in accordance with paragraph (2) above.
  - (i) the Purchaser shall hold the goods in a fiduciary capacity for us and shall store the same separately from any other goods in the Purchaser's possession and in a manner which enables them to be identified as our goods.
  - (ii) the Purchaser shall immediately return the goods to us should our authorised representative so request. All the necessary incidents associated with a fiduciary relationship shall apply.
- (d) the Purchaser's right to possess the goods shall cease forthwith upon the happening of any of the following events, namely :-
  - (i) if the Purchaser fails to make payment in full for the goods within the time stipulated in clause 4 hereof.
  - (ii) if the Purchaser, not being a company, commits any act of bankruptcy, makes a proposal to his or her creditors for a compromise or does anything which would entitle a petition for a Bankruptcy Order to be presented.
  - (iii) if the Purchaser, being a company, does anything or fails to do anything which would entitle an administrator or an administrative receiver or a receiver to take possession of any assets or which would entitle any person to present a petition for winding up or to apply for an administration order.
- (e) the Purchaser hereby grants to us an irrevocable licence to enter at any time any vehicle or premises owned or occupied by the Purchaser or in the possession of the Purchaser for the purposes of repossessing and recovering any such goods the property in which has remained in us under paragraph (2) above. We shall not be responsible for and the Purchaser will indemnify us against liability in respect of damage caused to any vehicle or premises in such repossession and removal being damaged which it was not reasonably practicable to avoid.
- (f) notwithstanding paragraph (3) hereof and subject to paragraph (7) hereof, the Purchaser shall be permitted to

sell the goods to third parties in the normal course of business. In this respect the Purchaser shall act in the capacity of our commission agent and the proceeds of such sale :-

- (i) shall be held in trust for us in a manner which enables such proceeds to be identified as such, and :
    - (ii) shall not be mixed with other monies nor paid into an overdrawn bank account.
- We, as principal, shall remunerate the Purchaser as commission agent a commission depending upon the surplus which the Purchaser can obtain over and above the sum, stipulated in this contract of supply which will satisfy us.
- (g) in the event that the Purchaser shall sell any of the goods pursuant to clause (6) hereof, the Purchaser shall forthwith inform us in writing of such sale and of the identity and address of the third party to whom the goods have been sold.

- (h) if, before property in the goods passes to the Purchaser under paragraph (2) above the goods are or become affixed to any land or building owned by the Purchaser it is hereby agreed and declared that such affixation shall not have the effect of passing property in the goods to the Purchaser. Furthermore if, before property in the goods shall pass to the Purchaser under paragraph (2) hereof, the goods are or become affixed to any land or building (whether or not owned by the Purchaser), the Purchaser shall:-

- (i) ensure that the goods are capable of being removed without material injury to such land or building.
- (ii) take all necessary steps to prevent title to the goods from passing to the landlord of such land or building.
- (iii) forthwith inform us in writing of such affixation and of the address of the land or building concerned.

The Purchaser warrants to repair and make good any damage caused by the affixation of the goods to or their removal from any land or building and to indemnify us against all loss damage or liability we may incur or sustain as a result of affixation or removal.

- (i) in the event that, before property in the goods has passed to the Purchaser under paragraph (2) hereof, the goods or any of them are lost, stolen, damaged or destroyed :-
- (ii) the Purchaser shall forthwith inform us in writing of the fact and circumstances of such loss, theft, damage or destruction.
- (iii) the Purchaser shall assign to us the benefit of any insurance claim in respect of the goods so lost, stolen, damaged or destroyed.

#### 14. NON-PAYMENT

If the Purchaser shall fail to make full payment for the goods supplied hereunder within the time stipulated in clause 4 hereof or be in default of payment for any other reason then, without prejudice to any of our other rights hereunder, we shall be entitled to stop all deliveries of goods and materials to the Purchaser, including deliveries or further deliveries of goods under this contract. In addition we shall be entitled to terminate all outstanding orders.

#### 15. VALUE ADDED TAX

All prices quoted are exclusive of Value Added Tax which will be charged at the rate ruling at the date of despatch of invoice.

#### 16. TRADE SALES ONLY

We are only prepared to deal with those who are not consumers within the terms of the Unfair Contract Terms Act 1977, the Sale of Goods Act 1979 and the Supply of Goods and Services Act 1982. Accordingly any person who purchases from us shall be deemed to have represented that he is not a consumer by so purchasing.

#### 17. JURISDICTION

The agreement is subject to English law for products delivered in England and Scottish law for products delivered in Scotland and any dispute hereunder shall be settled in accordance therewith dependent upon the location.

#### 18. PRODUCT DEVELOPMENT

Gledhill have a policy of continuous product development and may introduce product modifications from time to time.



FM 2057  
Controlled in accordance  
with ISO 9001:2008  
Quality System accepted  
by BSI



To protect our  
environment, we  
use copper a totally  
recyclable metal,  
which never  
becomes waste.



Our appliances are distributed through Gledhill Building Products depots at Blackburn, Bristol, Dudley, Hemel Hempstead, Huntingdon, Inverkeithing, Liverpool, Maidstone, Nottingham, Paignton, Reading, Southampton.

Information on the full range of Gledhill products can be found on the internet at [www.gledhill.net](http://www.gledhill.net)

Due to a programme of continuous improvement Gledhill Building Products reserve the right to modify products without prior notice.

It is advisable to check the product technical detail by using the latest design and installation manuals available from our technical support team or on our website.

Issue 02 06/10



"Only the best is acceptable"

### Gledhill Building Products Limited

Sycamore Estate, Squires Gate,  
Blackpool FY4 3RL

Tel: 01253 474550 Fax: 01253 474551

