

A-CLASS

mCHP BoilerMate

DESIGN, INSTALLATION AND SERVICING INSTRUCTIONS

Model Numbers

mCHP BMA 225
mCHP BMA 235



*The code of practice for the installation,
commissioning & servicing of central heating systems*

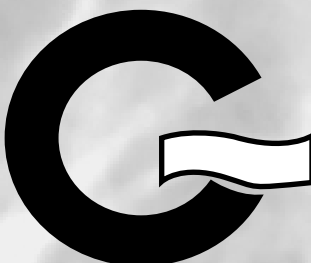

**A CENTRAL HEATING
AND MAINS PRESSURE HOT WATER
APPLIANCE INCORPORATING A THERMAL
STORE - FOR USE WITH mCHP UNITS IN
DOMESTIC DWELLINGS**

**ALL MODELS COMPLY WITH THE
WATER HEATER MANUFACTURERS
SPECIFICATION FOR INTEGRATED THERMAL
STORES**

MODELS

These appliances have been certified for safety and are WRAS approved and listed and are designed to be used with mCHP appliances in domestic dwellings. Therefore it is important these instructions are followed and used in conjunction with mCHP appliance manufacturer's instructions. The appliance and the installation specifications must not be modified unless recommended and approved by Gledhill Water Storage Limited.

SAFETY

1. THE GAS SAFETY (INSTALLATION AND USE) REGULATIONS 1998

"In your own interest, and that of safety, it is law that all gas appliances are installed by competent persons, in accordance with the above regulations. Failure to install appliances correctly could lead to prosecution."

2. CONTROL OF SUBSTANCES HAZARDOUS TO HEALTH

When working with insulation materials, avoid inhalation as it may be hazardous to health, avoid contact with skin, eyes, nose and throat. Use disposable protection. Dampen the material and ensure that the area is well ventilated.

3. INSTRUCTIONS

- **Read these Instructions in conjunction with the mCHP appliance installation instructions before installing or commissioning the appliance.**
- **Leave these instructions and the 'Benchmark' Log Book in the pocket provided on the back of the appliance front panel.**



*The code of practice for the installation,
commissioning & servicing of central heating systems*

Building Regulations and Benchmark Commissioning

The Building Regulations (England & Wales) require that the installation of a heating appliance be notified to the relevant Local Authority Building Control Department. From 1st April 2005 this can be achieved via a Competent Person Self Certification Scheme as an option to notifying the Local Authority directly. Similar arrangements will follow for Scotland and will apply in Northern Ireland from 1st January 06.

CORGI operates a Self Certification Scheme for gas heating appliances.

These arrangements represent a change from the situation whereby compliance with the Building Regulations was accepted if the Benchmark Logbook was completed and this was then left on site with the customer).

With the introduction of a self certification scheme, the Benchmark Logbook is being replaced by a similar document in the form of a commissioning check list and a service interval record is included with all gas appliance manuals. However, the relevant Benchmark Logbook is still being included with all Thermal Storage products and unvented cylinders.

Gledhill fully supports the Benchmark aims to improve the standards of installation and commissioning of central heating systems in the UK and to encourage the regular servicing of all central heating systems to ensure safety and efficiency.

Building Regulations require that the heating installation should comply with the manufacturer's instructions. It is therefore important that the commissioning check list is completed by the competent installer. This check list only applies to installations in dwellings or some related structures.

The Gledhill BoilerMate range is a WBS listed product and complies with the WMA Specification for integrated thermal storage products. The principle was developed in conjunction with British Gas. This product is manufactured under an ISO 9001:2000 Quality System audited by BSI.

Patents Pending

The Gledhill Group's first priority is to give a high quality service to our customers.

Quality is built into every Gledhill product and we hope you get satisfactory service from Gledhill.

If not please let us know.

Section	Page		Page
1.0	IMPORTANT NOTICES		4
2.0	SYSTEM DESCRIPTION		6
2.1	INTRODUCTION		6
2.2	OPERATION		8
2.2.1	Domestic Hot Water		8
2.2.2	Space Heating		8
2.2.3	Store Heating - Not Active		9
2.2.4	Store Heating - Active		9
2.2.5	Electric Backup		10
2.3	USER CONTROLS		11
2.3.1	On - Off Switch		11
2.3.2	Push button Functions		11
2.3.3	Red Lamp (LED) Functions		11
2.3.4	CH and HW Programmer		11
3.0	TECHNICAL SPECIFICATION		12
3.1	GENERAL		13
3.2	PUMP PERFORMANCE		16
3.3	HOT WATER PERFORMANCE		16
3.4	ELECTRICITY SUPPLY AND WIRING DIAGRAMS		18
3.5	APPLIANCE CONTROLLER		18
3.6	Appliance Selection		18
3.6.1	Display in Normal Mode		19
3.6.2	Sensor Temperature Reading		19
3.6.3	Control Temperature Set-point Reading		19
3.6.4	Fault Code Indication		19
3.6.5	Computer Interface		19
4.0	HEATING AND HOT WATER SYSTEM DESIGN		22
4.1	HOT AND COLD WATER SYSTEM		22
4.1.2	Use in Hard Water Areas		23
4.1.3	Hot and Cold Water Distribution Network		23
4.1.4	Taps and Shower fittings		23
4.1.5	Dead Leg Volumes		23
4.2	SPACE HEATING SYSTEM DESIGN		24
4.3	mCHP CIRCUIT DESIGN		25
5.	INSTALLATION AND WIRING		26
5.1	SITE REQUIREMENTS		26
5.2	PREPARING APPLIANCE FOR INSTALLATION		26
5.3	PIPEWORK CONNECTIONS		28
5.4	ELECTRICAL WIRING		29
5.4.1	General		29
5.4.2	Wiring the Appliance		29
6.	COMMISSIONING		32
6.1	INITIAL SYSTEM FILLING		32
6.2	CLEANSING AND WATER TREATMENT		32
6.2.1	Water Treatment		32
6.2.2	Power Flushing/Cleaning of the Heating System		32
6.2.3	Cleansing Hot & Cold Water and Treatment		32
6.3	COMMISSIONING mCHP UNIT & BOILERMATE		33
6.4	COMMISSIONING SPACE HEATING		33
6.5	COMMISSIONING DOMESTIC HOT WATER		34
6.6	COMMISSIONING THE STORE CHARGE CONTROL SET POINTS		34
6.7	HAND OVER TO USER		34
7.	SERVICING		34
7.1	ANNUAL SERVICE		34
7.2	CHANGING COMPONENTS		34
8.	SHORT PARTS LIST		35
	APPENDIX A		36
	APPENDIX B		37
	APPENDIX C		40
	APPENDIX D		41
9.	TERMS AND CONDITIONS OF TRADING		42

1.0 IMPORTANT NOTICES

1.1 HANDLING AND STORING THE APPLIANCE

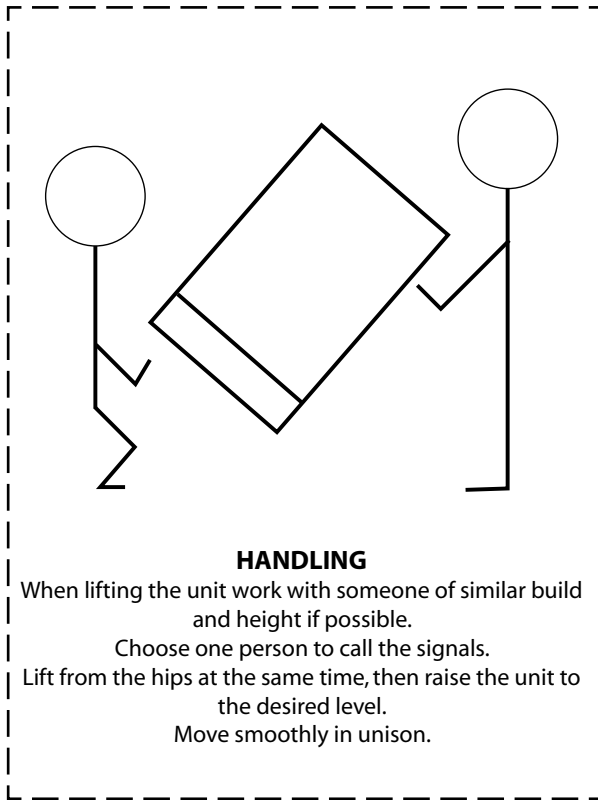

A specific manual handling assessment is shown in Appendix D at the rear of this manual.

This appliance should be handled carefully to avoid damage and the recommended method is shown opposite. A team lift - When lifting the unit:-

- Work with someone of similar build and height if possible.
- Choose one person to call the signal
- Lift from the hips at the same time, and then raise the unit to the desired level.
- Move smoothly in unison.

The appliance supplied shrink wrapped on a timber installation base. Carrying handles are provided towards the top of the left hand side of the casing and at the bottom of the opposite side.

If the unit needs to be stored prior to installation it should be stored upright in a dry environment and on a level base/floor.

Note: Although the above guidance is provided any manual handling/lifting operations will need to comply with the requirements of the Manual Handling Operations Regulations issued by the H.S.E.

The appliance can be moved using a sack truck on the left hand face although care should be taken and the route should be even. In apartment buildings containing a number of storeys we would recommend that the appliances are moved vertically in a mechanical lift. *If it is proposed to use a crane expert advice should be obtained regarding the need for slings, lifting beams etc.*

1.2 SYSTEM INSTALLATION

Any installation must be in accordance with the relevant requirements of the current issue of Gas Safety (Installation and Use) Regulations, Local Building Regulations, Local Water Company Bylaws and Health & Safety Document No. 635 – The Electricity at Work Regulations 1989. The detailed recommendations are contained in the current issue of the following British Standards and Codes of Practices: -

BS 5440 Pts. 1 & 2; BS 5449; BS 5546; BS 7074 Part 1; BS 6700; BS 6798; BS 6891, BS 7593, IGE/UP/7/1998

1.3 GAS CONSUMER COUNCIL

The Gas Consumer Council (GCC) is an independent organisation which protects the interest of all gas users. If you need advice, you will find the telephone number in your local telephone directory under Gas.

1.4 EQUIPMENT SELECTION

This information is provided to assist generally in the selection of equipment. Responsibility for selection and specification of our equipment must, however, remain that of our customers, mCHP appliance manufacturers and any expert or consultants concerned with the installation(s). Therefore please note that: -

- (a) We do not therefore accept any responsibility for matters of design selection or specification for the effectiveness of an installation containing one of our products.
- (b) All goods are sold subject to our Conditions of Sale which are set out in the Appendix to this document.

1.5 WARNINGS

As part of the industry wide 'Benchmark' initiative all mCHP BoilerMate^{A-CLASS} appliances now include a Benchmark Installation, Commissioning and Service Record Logbook. Please read this carefully and complete all sections relevant to this appliance. **Failure to do so may affect warranty.**

1.6 CONTINUOUS IMPROVEMENTS

In the interest of continuously improving the mCHP BoilerMate^{A-CLASS} range, Gledhill Water Storage Ltd reserves the right to modify the product without notice and in these circumstances this booklet which is accurate at the time of printing should be disregarded.

Gledhill Water Storage Limited
Sycamore Estate
Squires Gate
Blackpool
Lancashire
FY4 3RL

2.0 SYSTEM DESCRIPTION

2.1 INTRODUCTION

The mCHP BoilerMate^{A-CLASS} appliance shown in figure 2.1 is designed to provide improved space heating and mains pressure hot water and better electric and heat energy management when coupled to a domestic Micro Combined Heat and Power (mCHP) appliance. Any automatic mCHP unit designed to operate at flow temperature between 75°C and 85°C can be linked to the mCHP BoilerMate^{A-CLASS}. All models are fitted with an electric central heating and hot water backup/boost facility.

The principal of a mCHP BoilerMate^{A-CLASS} is to separate the heat generator e.g. mCHP appliance from the fluctuating space heating and domestic hot water demands by means of a thermal energy store. The main advantages and features of this arrangement are:-

- That the hot water can be supplied directly from the mains at conventional flow rates without the need for temperature and pressure relief safety valves or expansion vessels. This is achieved by passing the mains water through a plate heat exchanger. The outlet temperature of the domestic hot water is maintained by the system controller at about 52°C (at 18 l/min) by regulating the speed of the pump circulating the primary water from the store through the plate heat exchanger.
- It evens out the fluctuating and intermittent demands for space heating and hot water and enables the system to meet very high peak heat energy demands well above the thermal rating of the mCHP appliance.
- By storing heat energy produced when demand is low and discharging it when the demand is high (i.e. during dwelling warm up phase or when hot water is drawn off), a smaller heat generator can potentially be used.
- The use of a thermal store will also increase the mCHP continuous run times by virtually eliminating short cycles and thereby improve the reliability and utilisation efficiency of the mCHP appliance.
- The thermal store can accept energy from an other source e.g. solar and this can then be used for both space heating and domestic hot water (solar not yet available).

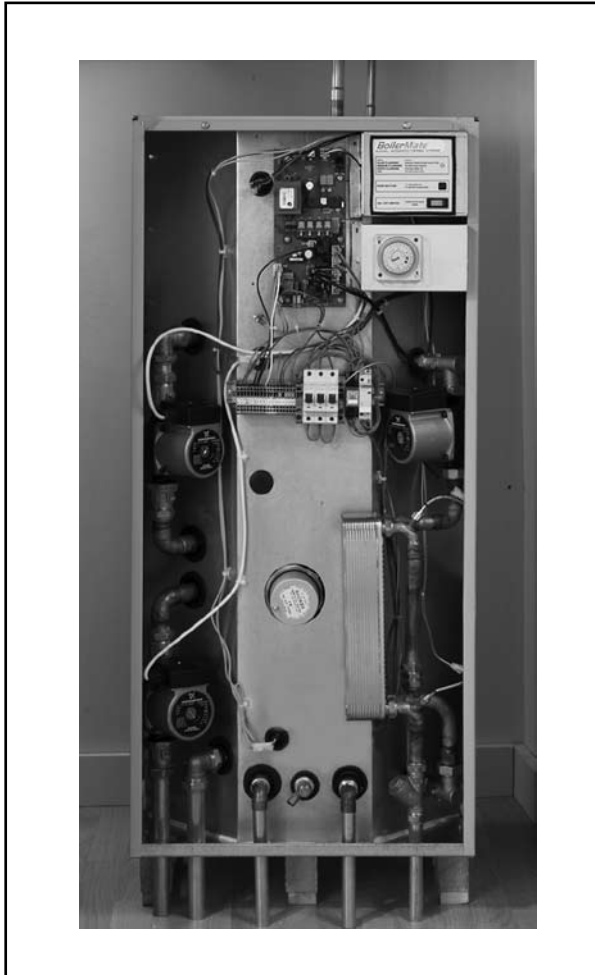

Figure 2.1 mCHP BoilerMate^{A-CLASS}

2.1 INTRODUCTION

The mCHP BoilerMate A-Class shown schematically in figures 2.1 and 2.2 is primarily designed for the new build market. The thermal store completely isolates the mCHP unit from the space heating and hot water demands and functions.

The heat losses from thermal stores should not be directly compared with heat losses from unvented or vented cylinders because they are treated differently in SAP. The SAP calculator takes account of the type of store and various correction factors are included to reflect the different ways that the hot water and heating operates.

For further information please request a copy of the SAP 2005 Data Sheet which provides the information required to produce SAP calculations for all Gledhill Thermal Storage products.

The Building Regulations L1A: New dwellings/L1B: Existing dwellings and the requirements set out in the Domestic Heating Compliance Guide specify that "where the mains water hardness exceeds 200ppm provision should be made to treat the feed water to water heaters and the hot water circuit of combination boilers to reduce the rate of accumulation of lime scale".

To comply with this requirement the hardness of the mains water should be checked by the installer and if necessary the optional factory fitted electronic in-line scale inhibitor should be specified at the time of order for hardness levels between 200 and 300 ppm (mg/l).

Where the water is very hard ie 300ppm (mg/l) and above the optional polyphosphate type, inhibitor should be specified at the time of order. However, this will need to be fitted by the installer at a suitable point in the cold water supply to the appliance.

If scale should ever become a problem the plate heat exchanger is easily isolated and quickly replaced with a service exchange unit which can be obtained at a nominal cost from Gledhill.

Because this product does not require a safety discharge from a temperature and pressure relief valve, any installations will not suffer from the problems associated with using PVCu soil stacks to take the discharge from unvented cylinders.

The mCHP BoilerMate^{A-CLASS} controls incorporate the following main functions:-

- They sense the demand for space heating and hot water from external user controls and switch on the appropriate system components to satisfy these demands.
- The space heating and plate heat exchanger pumps operate for a few seconds every 36 hours when there is no demand for space heating and domestic hot water to reduce the likelihood of the pumps and diverter valves sticking.
- They provide the mCHP pump overrun facility when necessary.
- Depending upon the store temperature and the energy demands, they provide switch on and off control signals for running the mCHP unit in normal and boost modes.
- Depending upon the store temperature and the energy demands, they also provide switch on and off control signals for the built in 6kW electric boost heater to satisfy short term peak space heating loads greater than the thermal rating of the mCHP unit.
- In the event of failure of the mCHP unit they provide the opportunity to manually energise the 'Switch' 6kW electric backup facility for hot water and central heating.

2.0 SYSTEM DESCRIPTION

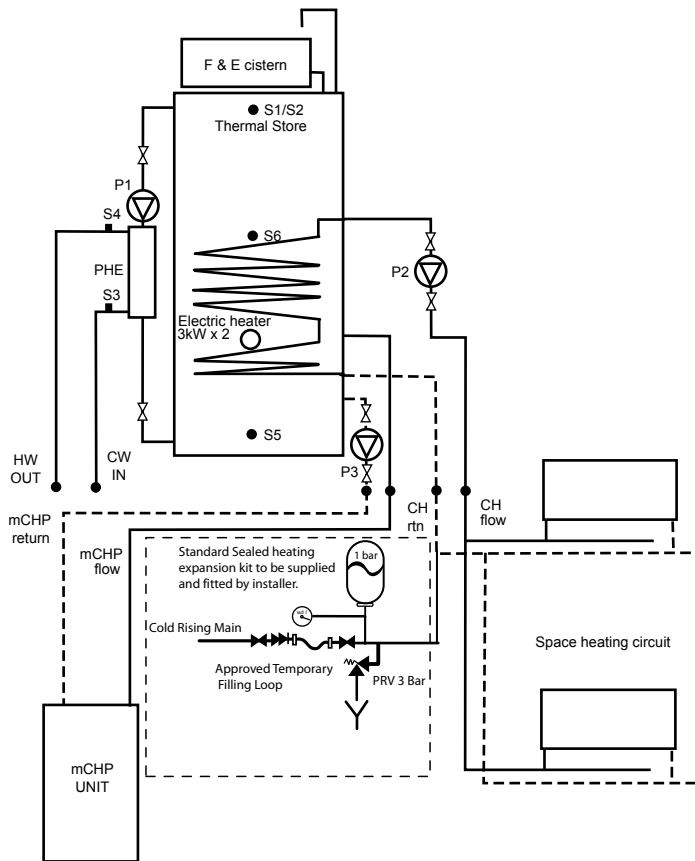

Figure 2.2 Schematic diagram of a typical mCHP BoilerMate A-Class 225 model installation

Note: With the 235 model, 2 F&E cisterns are provided

The mCHP BoilerMate^{A-CLASS} appliance user controls are shown in figure 2.5. All models are fitted with a single channel clock for programming heating 'on' times. All models can be supplied without this clock for use with a remote 2 channel programmer or programmable room thermostat etc. These should be supplied and specified by the installer.

2.2.1 DOMESTIC HOT WATER

In the standby mode, the controller maintains the plate heat exchanger between pre-set temperature limits by cycling the plate heat exchanger pump, P1. This cycling is controlled by sensors S3 and S4.

When a hot water tap is opened, the controller senses the flow of water by means of sensors S3 and S4 (figure 2.2) and activates the plate heat exchanger pump, P1. As long as the water is flowing the controller regulates the pump speed to maintain the domestic hot water delivery temperature at 52°C (at 18 l/min).

When the loss of hot water flow is sensed, the controller switches the pump, P1 off.

2.2.2 SPACE HEATING –

The central heating circuit is a separate sealed system and will require the installer to buy and fit a standard heating circuit expansion kit - see figure 2.2 for the connection arrangements. The space heating demand is controlled by the heating programmer and the room thermostat and its operation is independent of the operation of the mCHP.

When both the space heating programmer and the room thermostat are calling for heat, the controller senses these demands and switches on the central heating pump, P2. Therefore the central heating water is heated indirectly by means of a heat exchanger inside the store.

When either the programmer or the room thermostat stop calling for heat, the controller senses loss of space heating demand and switches off the central heating pump, P2.

If the store temperature falls below the pre-set limit (see table 3.5), the controller will either switch off the space heating pump or run it at minimum speed if modulating pump is fitted. The normal space heating pump operation will resume when the store temperature is greater than this pre-set limit. This is to provide a degree of priority to domestic hot water during high space heating demands.

The modulating central heating pump can be specified as an option. When this option is specified, the pump will modulate to control the space heating return temperature to a pre-set value.

2.2.3 STORE HEATING WHEN SPACE HEATING DEMAND IS NOT ACTIVE

The operation mode of the mCHP unit and the automatic electric boost is controlled by the store temperature sensors S1/2, S5 and S6 and the heating programmer. The store heating control logic depends upon the status of the space heating demand and is described below. The control set points are shown in table 3.5.

- (a) When the store temperatures T5 and T6 measured by sensors S5 and S6 are less than the S5 ON and S6 ON set points, the controller switches on the mCHP pump, P3 and sends the start /run signal to the mCHP unit.
- (b) When the store charging demand is active and the average top store temperature $(T1 + T6)/2$ is less than 'T_hw_boost_on' set point, the controller switches the mCHP unit to the boost run mode.
- (c) When the store charging demand is active and the average top store temperature $(T1 + T6)/2$ is greater than 'T_hw_boost_off' set point, the controller switches the mCHP unit to its normal run mode.
- (d) The store heating demand ceases when both store temperatures T5 and T6 are greater than S5_OFF and S6_OFF set points or if the programmer switches off the 'hot water' demand.
- (e) When the store heating demand ceases, the controller will send the stop signal to the mCHP unit and switch off the mCHP pump after the overrun period determined by the mCHP appliance.
- (f) If the store temperature exceeds 95°C when the store heating demand is active, the controller will switch off all active heat sources and activate the overheat safety trip lockout.

2.2.4 STORE HEATING - SPACE HEATING DEMAND ACTIVE

The store heating demand will only operate be accepted if either 'hot water' or 'space heating' demand is switched on by the programmer.

When both store temperatures T5 and T6 measured by sensors S5 and S6 are less than the S5_ON and S6_ON set points, the controller will switch on the mCHP pump, P3, and sends the start signal to the mCHP unit.

When both store and space heating demands are active and the average store temperature is less than 'T_CH_boost1_On' set point and the rate of temperature rise in the store is less than the R_CH_boost1 set point, the controller will send the signal to the mCHP to run in boost mode.

When both store and space heating demands are active and the average store temperature is greater than 'R_CH_boost1_Off' set point and the rate of temperature rise in the store is greater than the R_CH_boost1 set point, the controller will send the signal to the mCHP to run in normal mode.

When both store and space heating demands are active and the average store temperature is less than 'T_CH_boost2_On' set point and the rate of temperature rise in the store is less than the R_CH_boost2 set point, the controller will switch on the electric boost heater.

When both store and space heating demands are active and the average store temperature is greater than 'T-CH_boost2_Off' set point and the rate of temperature rise in the store is greater than the R_CH_boost 2 set point, the controller will switch off the electric boost.

The store heating demand ceases when both store temperatures T5 and T6 are greater than S5_OFF and S6_OFF set points.

When the store heating demand ceases, the controller will send the stop signal to the mCHP unit and switch off the mCHP pump after the overrun period determined by the mCHP appliance.

If the store temperature exceeds 95°C when the store heating demand is active, the controller will switch off all active sources and activate the overheat safety trip lockout.

2.0 SYSTEM DESCRIPTION

2.2.5 ' SWITCH' ELECTRIC BACK UP FACILITY

The mCHP_BoilerMateA-CLASS is fitted with an electric backup facility. If the mCHP unit does not supply heat when requested and fails to heat the store, the user has the option of selecting the electric backup system until the mCHP appliance operation is restored.

By moving the mode rocker on the front panel from 'normal' to 'switch' position, the electric backup boiler ie the 'switch' will be selected and this will be indicated by constantly lit red led on the front panel.

After the 'switch' backup system has been selected it will operate the same as the mCHP using the same set points as discussed in previous sections and also with same sensor error handling routines.

If the store temperature exceeds 95°C the controller will shut the heat source and activate the overheat safety trip lockout, the same as with a boiler.

The 'switch' backup system can be deselected at any time by the user by pressing the mode rocker back to 'normal' position. This will be indicated by the red LED on the front panel going off.

2.3 USER CONTROLS

The front panel controls are shown in figure 2.5 below.

2.3.1 ON-OFF SWITCH

This only isolates the control circuit power supply and therefore it should only be used for switching the appliance off for short periods e.g. testing and for resetting the appliance/controller to clear the lockout faults. **Before any service work is undertaken the mains electricity supplies to the BoilerMate and the mCHP appliance must be isolated at their respective 2-pole local isolators.**

2.3.2 PUSH BUTTON

This is used to reset the controller/appliance i.e. clear the lockout condition indicated by the rapid flashing red led.

2.3.3 RED LAMP (LED)

Indicates the :

- Off: Normal
- Slow flashing: 'Switch' backup system failure
- Medium flashing: 'Switch' backup selected
- Rapid flashing: Overheat/safety trip
- On: 'Switch' electric backup boiler is on

2.3.4 'SWITCH' OPERATION

By moving the mode rocker on the front panel from 'normal' to 'switch' position the electric backup boiler (switch) can be used as an alternative heat source for hot water and central heating, should there be a failure of the mCHP boiler. (See 2.2.7 Electric Backup Facility for further details)

2.3.5 CH Clock

The BoilerMate when used with an mCHP appliance is designed to be heated 24h/day and controls ensure that the mCHP is used efficiently with minimum cycling. Therefore the hot water heating is not timed and it is always available on demand.

The built in clock can be used to set central heating 'on' and 'off' times.

Note: If requested the mCHP BoilerMate A-Class can be fitted with an external 2 channel programmer to time control both hot water and central heating as an optional extra.

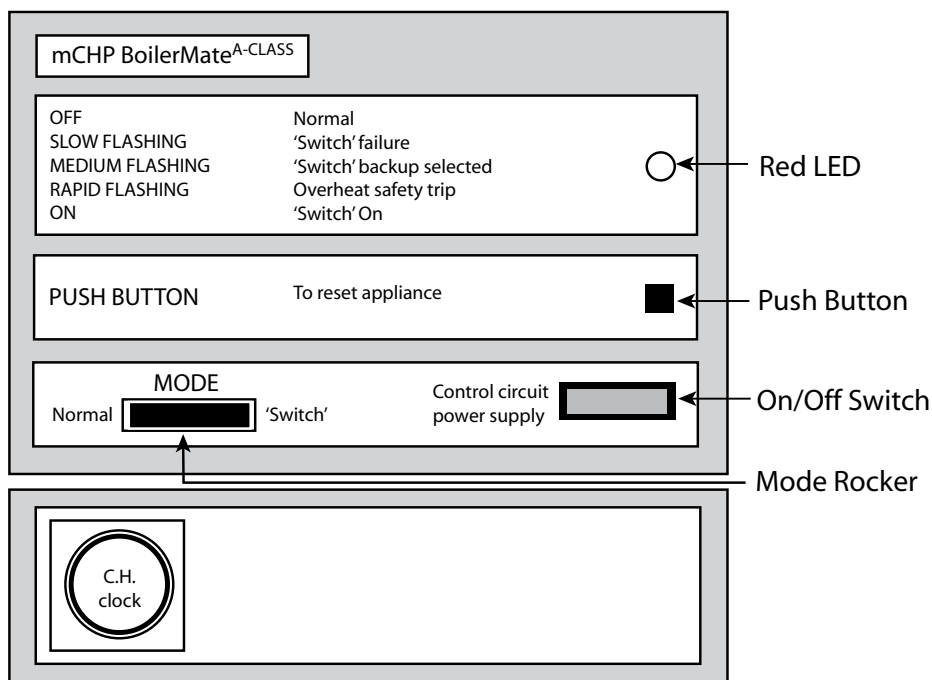
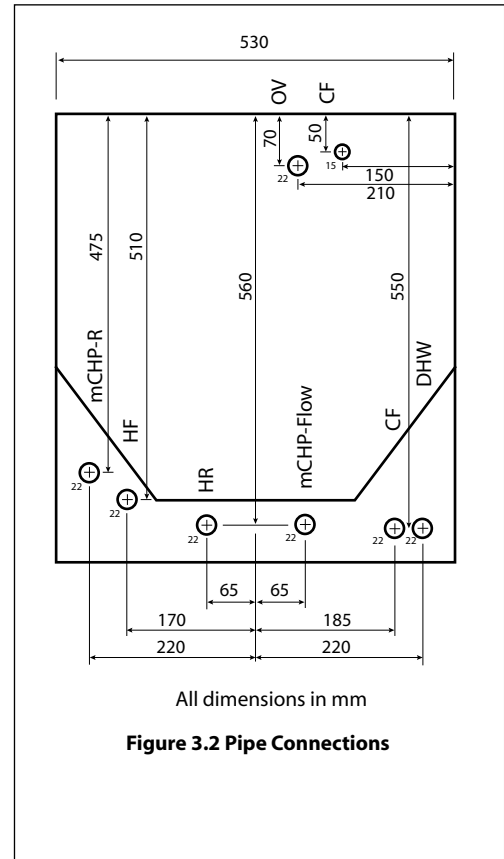
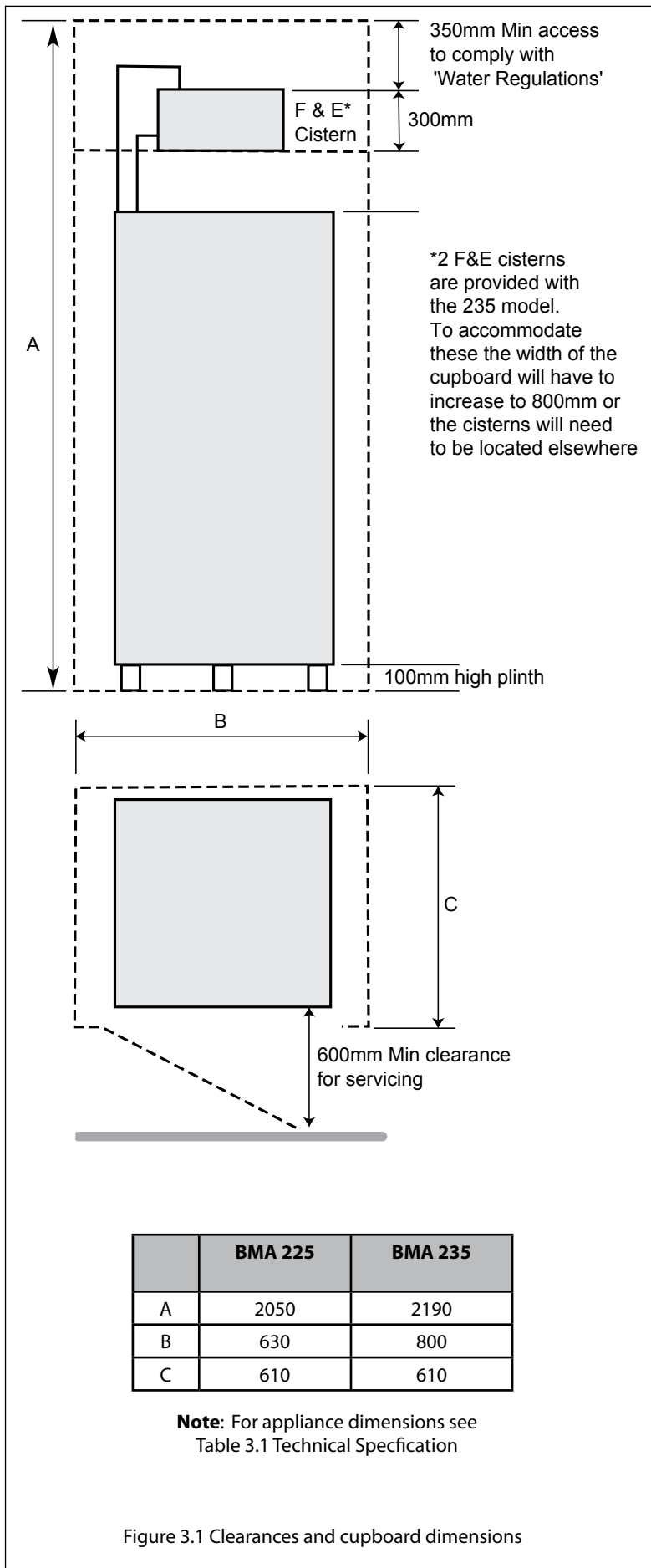

Figure 2.5 Appliance User Controls

3.0 TECHNICAL SPECIFICATION



TECHNICAL SPECIFICATION 3.0

3.1 GENERAL

The mCHP_BoilerMate^{A-CLASS} is only suitable for sealed heating systems and the technical specification is presented in tables 3.1 and 3.2. The model selection data is shown in table 3.3. The factory fitted or supplied standard components (shown in figures 2.1 and 2.2) and the optional components either factory fitted, supplied or available are listed in table 3.4.

These appliances are supplied on an installation base to allow the pipe runs to be connected to the appliance from any direction. It is easier if all pipes protrude vertically in the cut out area shown. Compression or push-fit connections can be used.

These appliances are normally installed in an airing cupboard and the minimum cupboard dimensions required are shown in figure 3.1. These dimensions only allow the minimum space required for the appliance including the F&E cistern. Any extra space required for shelving etc in the case of airing cupboard etc must be added.

The appliance pipe connection positions are shown in figure 3.2. All pipe positions are approximate only and are subject to tolerance of $\pm 20\text{mm}$ in any direction. A 15mm cold water supply and a 22mm warning/overflow pipe will also be required for the separate feed and expansion cistern.

Table 3.1 Technical Specification of mCHP BoilerMate ^{A-CLASS} - Physical Data				
			BMA225	BMA235
Storage volume	Nominal Storage Capacity	litres	186	210
Appliance weight	Empty	kg	49	53
	Full	kg	235	263
Appliance dimension	height	mm	1300	1440
	width	mm	530	530
	depth	mm	595	595
Maximum working head - Thermal Store		mWG	10m - Suitable only for open vented system	
Cold water mains supply dynamic pressure	Minimum	bar	1bar, HW supply & distribution will be poor	
	Recommended	bar	2-3, For good HW service	
	Maximum	bar	5, PRV set at 3.0bar must be fitted above 5bar	
Pipe connections	MCW & DHW	mm	22	22
	Safety open vent	mm	22	22
	Cold feed & expansion	mm	22	22
	Boiler flow and return	mm	22	22
	CH flow and return	mm	22	22
	CH flow & return	mm	22	22
	Towel rail(2)	mm	15	15
	Drain connection	mm	R1/2"	R1/2"

3.0 TECHNICAL SPECIFICATION

Table 3.2 Technical specification of mCHP BoilerMate^{A-CLASS} Thermal and Electrical Data

			BMA225	BMA235
Time to heat whole store (10-75°C)	8kW thermal mCHP	min	116	131
	10kW thermal mCHP	min	93	105
	15kW thermal mCHP	min	62	70
Time to heat top of store (10-75°C)	6kW electric backup 'Switch'(1)	min	77	87
Time to recover whole store (35-75°C)	8kW thermal mCHP	min	71	81
	10kW thermal mCHP	min	57	65
	15kW thermal mCHP	min	38	43
Time to recover top of store (35 to 75°C)	6kW electric backup 'Switch'(1)	min	47	54
Maximum thermal rating of the mCHP unit		kW	12	15
Maximum pressure heating circuit		bar	3 bar	3 bar
Volume of primary coil		litres	5 litres	5 litres
Expansion vessel size		litres	6 - 8 litres	6 - 8 litres
Allowance for hot water load (3)		W	750	1,000
DHW flow rate at 35K temperature rise (4)		l/min	Up to 35	Up to 35
Hot water draw-off volume at 35K temperature rise & at 18 l/min (4) from fully charged store		litres	250	282
Thermal insulation characteristics	Type		PU-Foam, 'Zero 0DPM' and metal cased	
	Average thickness	mm	52	52
	Heat loss rate(5)	kWh/24h	2.452	2.635
Electrical Data			BMA225	BMA235
Electrical rating at 230V ac, 50Hz, 1 ph supply(6)		W	6,500 (approximate 28A) Supply must rated at 32A minimum	
Maximum power consumption at 230V ac, 50Hz	Standby mode	W	30	
	mCHP - Operating (7)	W	300	
	'Switch' - Operating	W	6,300	
	Control/Boiler system	W	1 x 6A MCB	
Internal circuit	Control/Boiler system	W	1 x 6A MCB	
Protection devices	'Switch' backup		2 x 16A MCB	

Notes:

- (1) All mCHP BoilerMate^{A-CLASS} models are fitted with a 6kW electric backup system i.e. 'Switch' which is used to boost the heat in the store if the output from the mCHP unit is not sufficient in extreme demand conditions, The 'switch' is also used to provide backup heating and hot water in the rare event the mCHP unit fails.
- (2) The hot water allowance used for adding to the design heat loss of the dwelling (BS6700) for sizing the thermal rating of the mCHP unit.
- (3) Based on the average store charge temperature of 77°C and mains cold water inlet temperature of 10°C
- (4) Heat losses measured at 55K steady temperature difference as specified in the WMA Specification for Thermal Stores
- (5) 6kW 'Switch' is integrated in the mCHP BoilerMate^{A-CLASS} control system. Therefore electricity supply to the appliance via the two pole isolator must be rated at 6.5kW at 230V ac, 50Hz. It assumed that the mCHP unit is supplied via separate isolator and boilerMate only provides the control signal.
- (6) mCHP unit takes its power from an independent circuit via its own isolator.

TECHNICAL SPECIFICATION 3.0

Table 3.3 Model Selection Guide

		BMA225	BMA235
Maximum design heat loss of the dwelling	(kW)	6.0	8.0
Maximum number of bathrooms/En-suite shower rooms		1/1	2/1

Table 3.4 Factory fitted or supplied standard and optional equipment

		BMA 225 BMA 235
1	mCHP / System pump - Grundfos UPS 15-50 mCHP / System pump - Grundfos UPS 15-60	S -
2	Space heating pump - Grundfos UPS 15-50 Space heating pump - Grundfos UPR 15-50 (Modulating)	S O
3	Plate heat exchanger pump - Grundfos UPR 15/50	S
4	3-Port flow share valve - Honeywell 22mm	-
5	Plate heat exchanger - SWEP E8T/24	S
6	Cold water inlet Y-Line strainer with flow regulator	S
7	6kW 'Switch' electric backup system	S
8	1 x Store duplex overheat sensor	S
9	2 x Store single sensor	S
10	1 x Cold water inlet single sensor	S
11	1 x Hot water outlet single sensor	S
12	Front panel display	S
13	2 x 16A MCB for 'Switch' backup circuit	S
14	1 x 6A MCB for appliance control circuit	S
15	DIN Rail wiring terminals & control gear	S
16	PJN 147 Appliance controller	S
17	Electromechanical Programmer	S
18	Automatic bypass valve	-
19	Feed and expansion cistern - complete with ballvalve and float	S - (2)
20	Danfoss 2-Channel programmer for remote fixing	OS - (1)
21	Danfoss 2-Channel programmable room thermostat for remote fixing	OS - (1)
22	Electronic type scale inhibitor	O
23	Polyphosphate type scale inhibitor	OS

Notes:

S - Standard factory fitted equipment

O- Optional factory fitted equipment

OS- Optional equipment for site fitting by installer

(1) For these options, the BoilerMate with 'NO' clock option must be specified

(2) Two F&E cisterns are supplied with the 235 model

3.0 TECHNICAL SPECIFICATION

Figure 3.3 Performance range of Grundfos UPS 15-50 pump

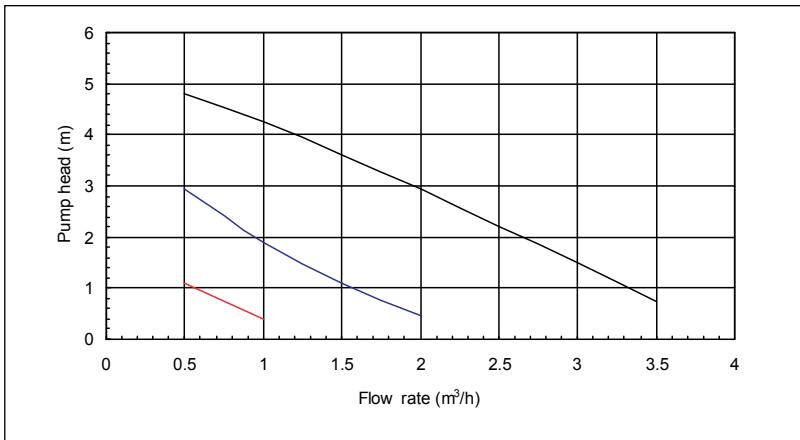

Figure 3.4 Performance range of Grundfos UPS 15-60 pump

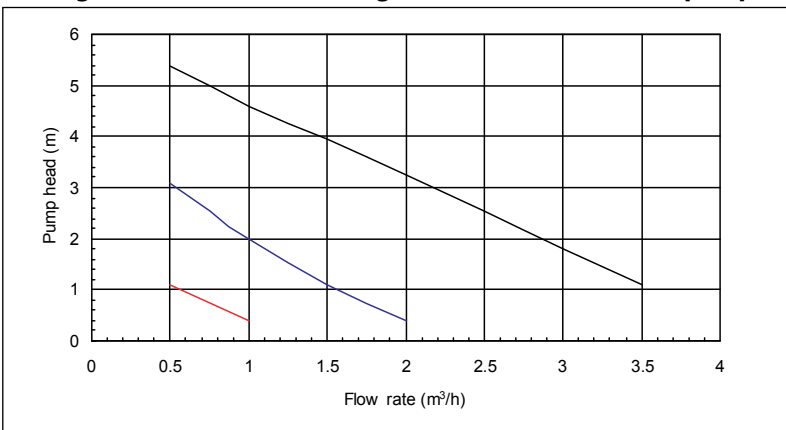
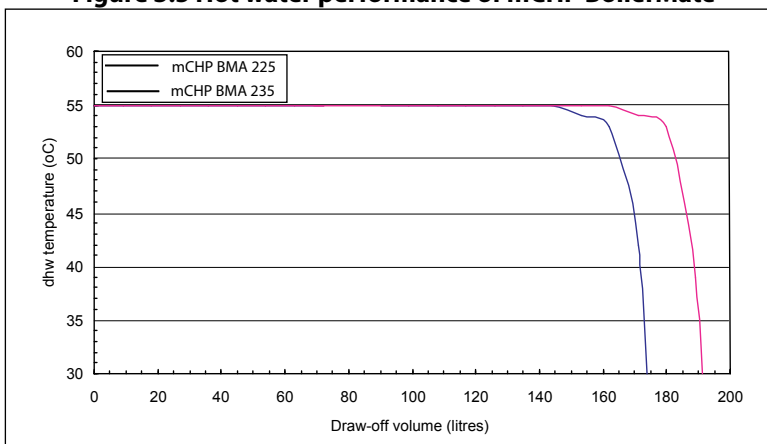

Figure 3.5 Hot water performance of mCHP BoilerMate



3.2 PUMP PERFORMANCE

The performance of Grundfos UPS 15-50 and UPS 15-60 pumps fitted in the appliances are shown in figures 3.3 and 3.4 respectively. The maximum performance of the modulating pumps (UPR range) is the same as the UPS range set at speed 3. As these pumps modulate their performance characteristics change downwards the same as setting lower speeds for non-modulating standard pumps.

The resistance of the 3-port flow share valve, and the mCHP unit should be taken into account when sizing the pipework for central heating and boiler circuits.

3.3 HOT WATER PERFORMANCE

Although the mCHP BoilerMate^{A-CLASS} will operate at mains inlet pressure as low as 1 bar and as high as 5 bar; the preferred range is 2 – 3 bar dynamic.

Typical hot water performance of the appliance is shown in figure 3.5. The performance comparison is shown for continuous hot water draw-off at 18 l/min when the store is charged to nominal 77°C and the cold water inlet temperature is 10°C. Also during the draw-off it is assumed that there is no heat input from the mCHP unit.

TECHNICAL SPECIFICATION 3.0

FIGURE 3.6

3.4 ELECTRICITY SUPPLY AND WIRING DIAGRAMS

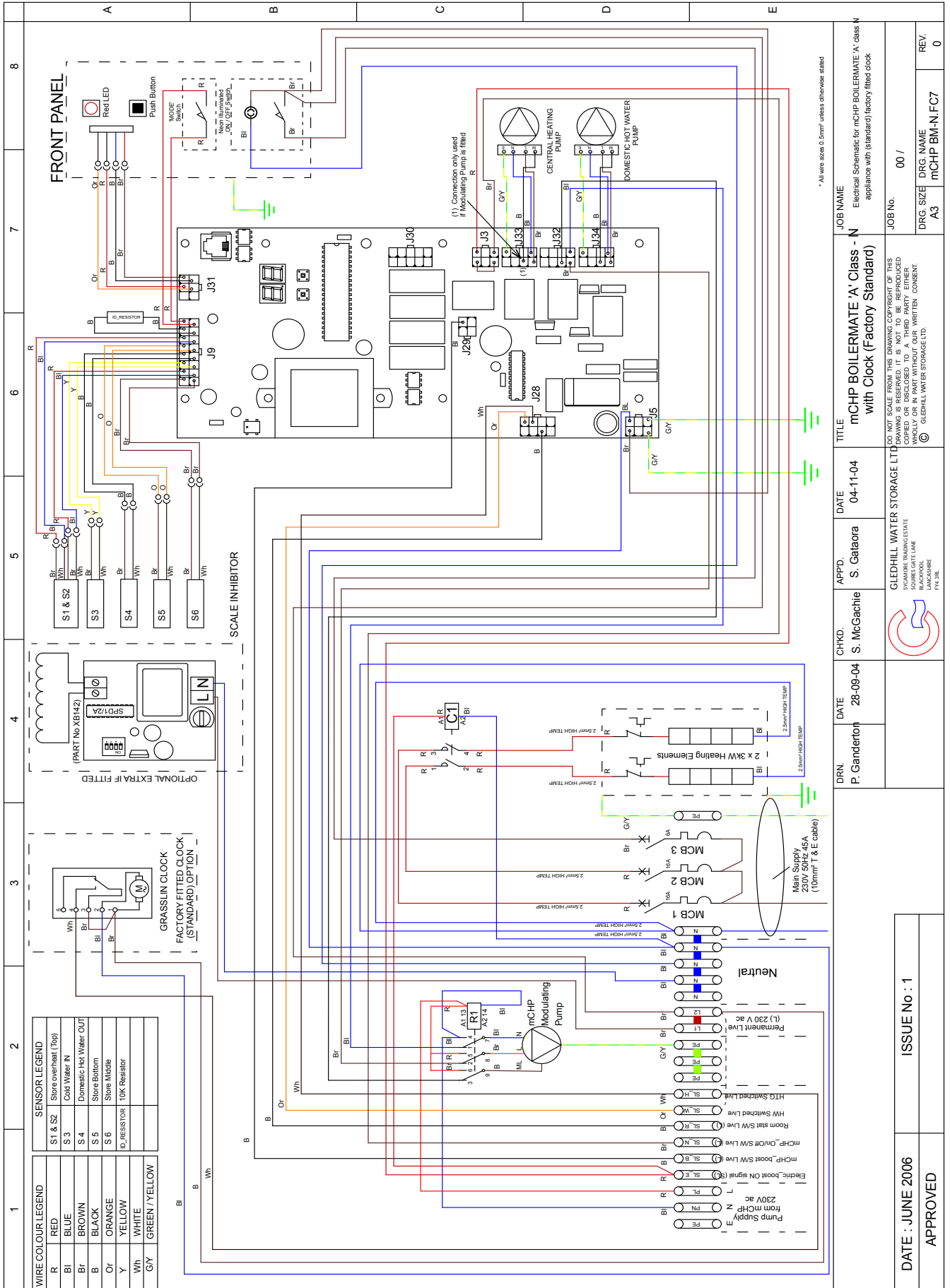

3.0 TECHNICAL SPECIFICATION

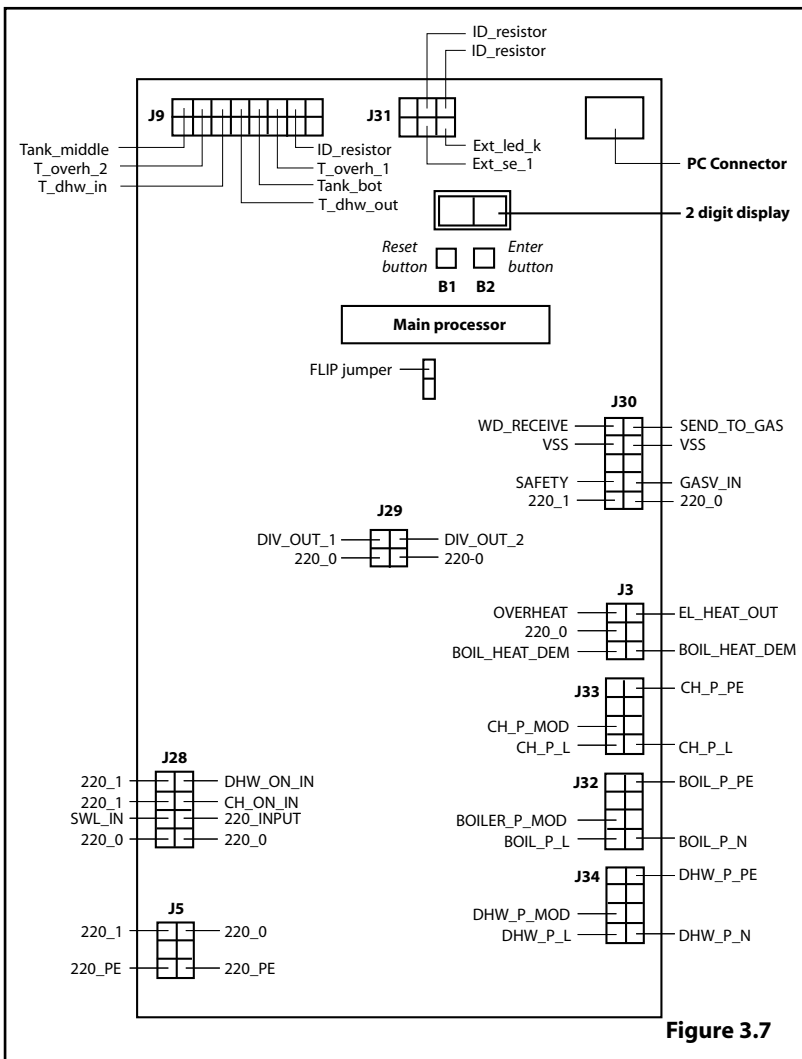

Figure 3.7

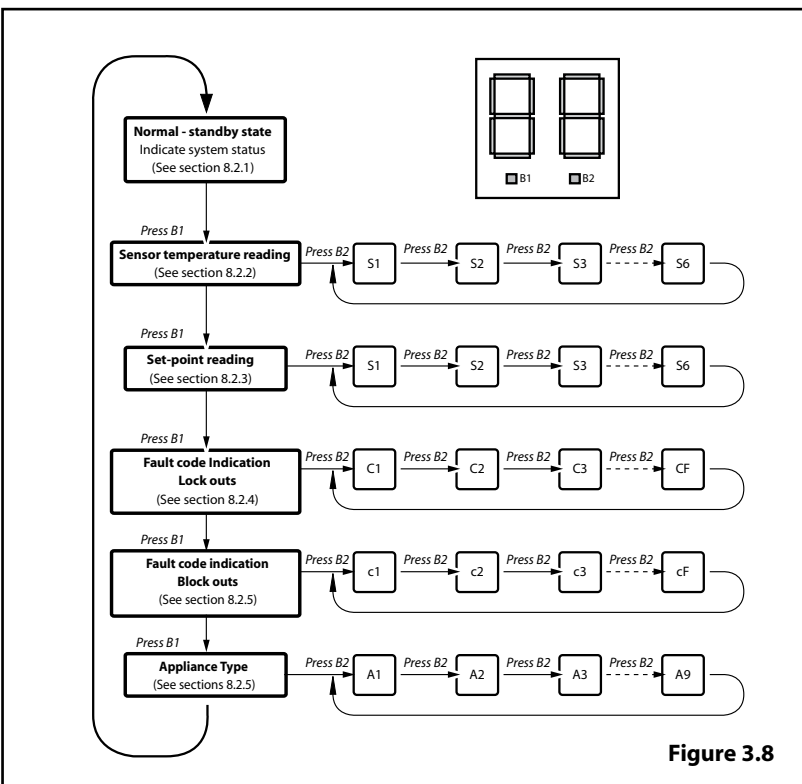

Figure 3.8

3.4 ELECTRICITY SUPPLY AND WIRING DIAGRAMS

The mCHP_BoilerMate^{A-CLASS} is fitted with a electric backup heater rated at 6kW as standard. Therefore the single mains electricity supply to the appliance must be rated at 32A at 230V ac and connected to the appliance through a 2-pole local isolator. All fuses must be ASTA approved to BS 1362. This supply is internally split and fused for the control and power circuits. This appliance **MUST BE EARTHED**.

The BoilerMate only supplies the control signal power to the mCHP unit. Therefore the mCHP unit must be connected to the mains supply via its dedicated 2-pole isolator as per manufacturer's instructions.

The internal wiring diagram is shown in figure 3.6 and typical external wiring arrangement is shown schematically in figure 5.2.

3.5 APPLIANCE CONTROLLER

The appliance controller (figure 3.7) has a 2 digit display and 2 push buttons which are used to check the status of the appliance, check and set its identity and interrogate it for the current faults and the fault history.

The 2 digit display on the main PCB is controlled by 2 buttons B1 and B2. The flow chart of display modes is shown in figure 3.8. Generally, each press of button B1 cycles the display from top to bottom and each press of button B2 cycles the display functions from left to right.

The buttons B1 is also used to reset the appliance i.e. clear the lockout errors and reset the appliance. (Note: Appliance resetting can also be carried out using the push button on the front panel). See figure 6.2 for further details of the 2 digit digital display.

3.6 APPLIANCE TYPE SELECTION

The mCP BoilerMate^{A-CLASS} is fitted with an identity (ID) resistor which is read by the controller for comparison with the appliance type (code) set on the controller. The two must match for the controller/appliance to function. Therefore if either the appliance code setting or the ID resistor is wrong, the appliance will shut down safely and flag the error code until the fault is rectified. The controller codes and the ID resistor values for the mCHP-BoilerMate^{A-CLASS} are listed in table 3.6. The procedure for

checking and setting the appliance code on the controller is described below.

- The appliance selection menu (A0 ...A9) on the controller is hidden. It is only possible to get to the appliance selection using the reset button (Left hand, B1) on the main board.
- When going from the show 'locking error' to show 'blocking error' menu (see figure 3.10), do not release the button but hold it for 10 seconds. The display will change from 'c' to 'A'. At this stage the push button (B1) can be released.
- The appliance type can now be selected by using right hand push button, B2, e.g. A03.

Press the reset button, B1, to accept the setting.

If the selected appliance code does not match with the ID resistor fitted to the appliance, then, an error '33' will be displayed.

3.6.1 DISPLAY IN NORMAL (STANDBY) MODE

In the standard/normal mode the 2 digit display shown in figure 6.2 indicates the status of the appliance inputs and outputs by switching on the appropriate segments of the display.

3.6.2 SENSOR TEMPERATURE

The sensors used in this appliance are listed in table 3.7. In this mode the current temperature read by the selected sensor is displayed. The temperature reading is displayed by alternatively flashing the sensor number and its temperature reading or the error code shown in section 3.6.5.

3.6.3 CONTROL TEMPERATURE SET POINT READING

In this mode the set points used in controlling the store heating and hot water generation are displayed. The set point is displayed by alternatively flashing the S1 ...S6 and the corresponding set point. The available set-point reading are shown in table 3.8

3.6.4 FAULT CODE INDICATION

The fault codes are divided into the following categories and are tabulated in table 3.9

- Locking Errors - These errors clear automatically when the fault is cleared and these error codes are preceded by letter 'C' on the 2-digit controller display. These errors will clear automatically when the fault is rectified.
- Blocking Errors - These errors can only be cleared by resetting the controller and these error codes are preceded by letter 'c' on the digit controller display.
- Non critical sensor errors are stored in warning tables and under these conditions the controller uses alternative control strategies to keep appliances functioning and provide limited service.

E1	Open Circuit
E2	Short Circuit
E3	Temperature greater than 99°C

3.6.5 COMPUTER INTERFACE

A laptop computer can be connected to the controller for commissioning, system monitoring and fault diagnostics. Typical system status display screen on a PC is shown in figures 3.11 and 3.12. The system control parameters can only be changed within the pre-set limits by means of a PC and appropriate software to fine tune the system.

In the short term the software necessary for this is restricted for use by the manufacturer.

3.0 TECHNICAL SPECIFICATION

Table 3.5 System Control Set Points

		BMA 225 BMA 235
1	DHW control temperature, sensor S4	55°C
2	Hot water priority ON set point, Sensor S6	54°C
	Hot water priority OFF set point, Sensor S6	58°C
3 ⁽¹⁾	CH Pump max speed	255
	CH Pump min speed	110
	CH return temperature set point, Sensor S5	55°C
4	Bottom store sensor, S5, ON set point	60°C
	Bottom store sensor, S5, OFF set point	70°C
5	Middle store sensor, S6, ON set point	68°C
	Middle store sensor, S6, OFF set point	77°C
6	mCHP boost ON set point in HW only mode (T_HW_boost_on)	52°C
	mCHP boost OFF set point in HW only mode (T_HW_boost_off)	57°C
7	mCHP boost ON set point in CH only mode (T_CH_boost1_on)	55°C
	mCHP boost OFF set point in CH only mode (T_CH_boost1_off)	65°C
	mCHP boost ON/OFF rate of change set point (R_CH_boost1)	
8	Electric boost ON set point in CH only mode (T_CH_boost2_on)	40°C
	Electric boost OFF set point in CH only mode (T_CH_boost2_off)	50°C
	Electric boost ON/OFF rate of change set point (R_CH_boost2)	
9	Overheat set point, Sensor S1/S2	95°C

Notes: ⁽¹⁾ Only when modulating pump option is specified

Table 3.6 mCHP BoilerMate^{A-CLASS} Identification Values

Models	ID Resistor Value	Controller Code
mCHP BMA 225	10K	A06
mCHP BMA 235		

Table 3.7 sensor used in mCHP BoilerMate

Display	Sensor	Connector J9 pins	Location
S1	T Overheat 1	6 & 14	Top of store in dry pocket (S1 & S2 are in single housing)
S2	T Overheat 2	2 & 10	
S3	T DHW in	3 & 11	In cold water inlet pipe (Wet i.e. direct)
S4	T DHW out	4 & 12	In hot water outlet pipe (Wet i.e. direct)
S5	T Tank bottom	5 & 13	Bottom of store in dry pocket for Off-Peak IH
S6	T Tank middle	1 & 9	Middle of store in dry pocket for On-Peak IH

TECHNICAL SPECIFICATION 3.0

Table 3.8 Sensor Sensor control set point readings

Display	Sensor
S1	Top/middle store sensor, S6, ON set point
S2	Top/middle store sensor, S6, OFF set point
S3	DHW Inlet sensor, S3, set point
S4	DHW Outlet sensor, S4, set point
S5	Bottom store sensor, S5, ON set point
S6	Bottom store sensor, S5, OFF set point

Table 3.9 Controller Error Codes and Descriptions

LOCKING ERRORS		BLOCKING ERRORS		ERROR TABLE DHW	
No	Definitions	No	Definitions	No	Definitions
0	E ² PROM READ ERROR	25	REFHI_TOO_LO ERROR	0	T_DHW_OUT_OPEN
1	SAFETY RELAY ERROR	26	REFHI_TOO_HI ERROR	1	T_DHW_IN_OPEN
2	E ² PROM ERROR	27	REFLO_TOO_LO ERROR	2	T_DHW_OUT_SHORTED
3	WRONG E ² PROM SIGNATURE	28	REFLO_TOO_HI ERROR	3	T_DHW_IN_SHORTED
4	ROM ERROR	29	WD_COMMUNICATION ERROR		
5	RAM ERROR	30	PHASE_ERROR		
6	20MS ERROR	31	50HZ_ERROR		
7	41MS ERROR	32	RESET_BUTTON_ERROR	WARNING TABLE	
8	STACK ERROR	33	APPLIANCE SELECTION ERROR	No	Definition
		34	SPARE_BLOCK_ERROR_34	0	T_TANK_MIDDLE_OPEN
10	OVERHEAT ERROR	35	SPARE_BLOCK_ERROR_35	1	T_TANK_BOTTOM_OPEN
11	OVERHEAT DIFFERENCE ERROR	36	GP_LOST_ERROR	2	T_TANK_MIDDLE_SHORTED
12	T_MAX LOCK ERROR	37	T_OVERHEAT_/_OPEN	3	T_TANK_BOTTOM_SHORTED
		38	OPEN_SENSOR_1	4	EB_FAILURE
		39	OPEN_SENSOR_2		
		40	T_ID_OPEN		
		41	OPEN_SENSOR_4		
17	15MS ERROR	42	OPEN_SENSOR_5		
18	FLAG BYTE INTEGRITY ERROR	43	OPEN_SENSOR_6		
19	AD_HI_CPL ERROR	44	T_OVERHEAT_2_OPEN		
20	AD_LO_CPL ERROR	45	SHORTED_SENSOR		
21	REGISTER ERROR	46	SHORTED_SENSOR_1		
		47	SHORTED-SENSOR_2		
23	BOILER RELAY ERROR	48	T_ID_SHORTED		
24	EH_RELAY ERROR	49	SHORTED_SENSOR_4		
		50	SHORTED_SENSOR_5		
		51	SHORTED_SENSOR_6		
		52	T_OVERHEAT_2_SHORTED		
		54	ID_ERROR		
		55	TOP_IH_FAILURE		
		56	BOT_IH_FAILURE		

4.0 HEATING AND HOT WATER

4.1 HEATING AND HOT WATER SYSTEM DESIGN

- (a) All recommendations with regard to pipe work systems in this manual are generally based on the use of BS/EN Standard copper pipework and fittings.
- (b) However the plastic pipework system can be used in place of copper internally as long as the chosen system is recommended by the manufacturer for use in cold and hot water systems and is fully designed and installed in accordance with their recommendations.
- (c) This is particularly important in relation to use of push fit connections when using the optional flexible hose kits (See Installation and Wiring section of this document).
- (d) It is also important that if an alternative pipework material or system is chosen, then, the manufacturer confirms that the design criterion for the new system is at least equivalent to the use of BS/EN Standard copper pipework and fittings.

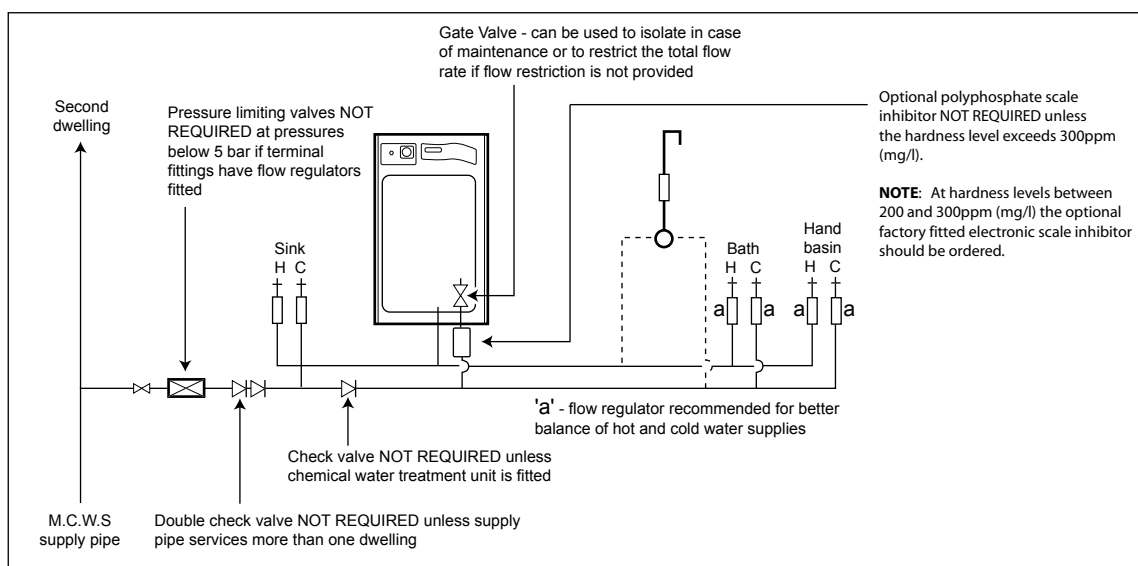

Figure 4.1 Typical hot and cold water distribution pipework in a dwelling

4.1.1 MAINS PRESSURE AND WATER SUPPLY

- (a) mCHP_BoilerMate is designed to be connected directly to the mains and fulfil the requirements of Water Byelaw 91 and therefore do not require a check valve to be fitted to the supply pipe. However, should ancillary equipment requiring a non-return valve, is to be fitted to the same mains supply as the BoilerMate, then this valve must not be fitted between the inlet of this mains supply to the property and the BoilerMate (see figure 4.1).
- (b) The hot water flow rate achievable from the BoilerMate and the performance of the domestic hot and cold water systems is directly related to the adequacy of the cold water mains serving the property. For this reason the cold water supply to the dwelling must be capable of providing for those services which could be required simultaneously and this maximum demand should be calculated. Also if a water meter is fitted its nominal rating should match the anticipated maximum simultaneous hot and cold water demand calculated in accordance with BS 6700. This could be 50 litres per minute in some properties.
- (c) All models of the mCHP BoilerMate will operate at pressure as low as 1 bar but the recommended range is between 2 and 3 bar. These pressures must be dynamic and be available at the appliance when local demand is at its maximum.
- (d) As a general guideline, although a 15mm service may be sufficient for smaller dwellings with one bathroom, a 22mm service (25mm MDPE) is preferred and should be the minimum for larger dwellings.
- (e) If the incoming mains pressure exceeds 5 bar at any time in a 24 hour cycle, then, a pressure regulating valve set at 3.5 bar should be fitted down stream of the stop tap where the cold supply enters the property.
- (f) Equipment used in the system should be suitable for a working pressure of up to 5bar.

4.1.3 COLD AND HOT WATER DISTRIBUTION NETWORK

- (a) As a minimum, it is recommended that the cold supply to the appliance internally is run in 22mm copper or equivalent in plastic and then from the appliance in 22mm past the hot water draw-off to the bath .
- (b) We would recommend that best results for balanced system are achieved by fitting appropriate flow regulators to each hot and cold water outlets. These must be fitted in cases where the final branch pipe sizes are not as recommended in (c) below or the water pressures are above the recommended 2 – 3 bar range.
- (c) Alternatively the tee-offs to the outlets should be in 10mm except for bath and shower, which should be in 15mm (1 metre minimum length).
- (d) The hot water supply to a shower-mixing valve should be the first draw-off point on the circuit. The cold water supply to a shower-mixing valve should be fed directly from the rising main and should be the first draw off point on the cold water circuit.
- (e) It is important that the cold water pipe work is adequately separated from any heating/hot water pipe work to ensure that the water remains cold and of drinking water quality.

4.1.4 TAPS AND SHOWER FITTINGS

- (a) Ensure that all terminal fittings are suitable for mains pressure. Use aerated taps whenever possible to prevent splashing.
- (b) Any shower mixing valve used must be suitable for mains fed hot and cold supplies. However all mains pressure water systems are subject to dynamic changes particularly when other hot and cold water taps are opened and closed. For this reason, a thermostatic shower MUST be used with this appliance.
- (c) Note that the shower fittings must comply with the backflow prevention requirements (Para 15, Schedule 2) of the Water Supply Regulations 1999.
- (d) A bidet can be supplied from the mCHP BoilerMate appliance as long as it is of the over rim flushing type and incorporates a suitable air gap.

4.1.2 USE IN HARD WATER AREAS

- (a) The control system prevents the domestic water from exceeding 55°C for most of the operational time of the appliance and therefore limits the formation of scale .
- (b) The Building Regulations L1A: New dwellings/L1B: Existing dwellings and the requirements set out in the Domestic Heating Compliance Guide specify that “where the mains water hardness exceeds 200ppm provision should be made to treat the feed water to water heaters and the hot water circuit of combination boilers to reduce the rate of accumulation of lime scale”

To comply with this requirement the hardness of the mains water should be checked by the installer and if necessary the optional factory fitted in-line scale inhibitor should be specified at the time of order for hardness levels between 200 and 300 ppm (mg/l).

Where the water is very hard ie 300ppm (mg/l) and above the optional polyphosphate type, inhibitor should be specified at the time of order. However, this will need to be fitted by the installer at a suitable point in the cold water supply to the appliance.

- (c) If scale should ever become a problem the plate heat exchanger is easily isolated and quickly replaced with a service exchange unit which can be obtained at a nominal cost from Gledhill.

4.1.5 DEAD LEG VOLUMES

If the dead leg volumes of the hot water draw-off pipework is excessive and the delivery time will be more than 60 seconds before hot water is available at the tap, you may consider using trace heating such as the 'RaychemHWAT' system. Please call Gledhill technical department for further details.

4.0 HEATING AND HOT WATER

4.2 SPACE HEATING DESIGN

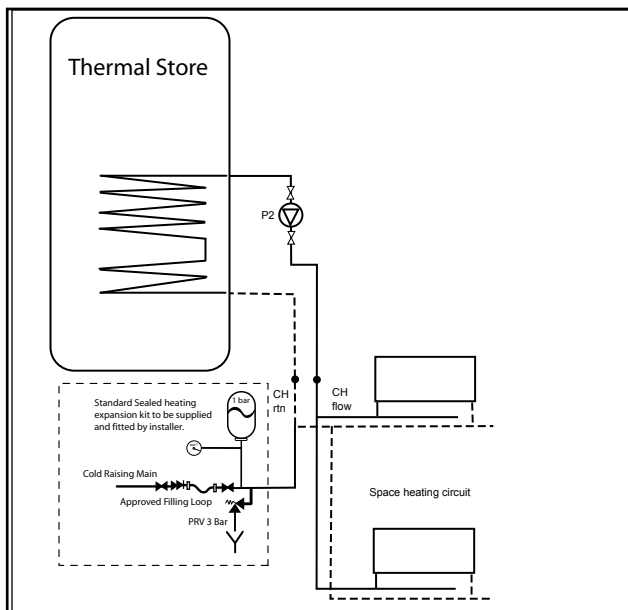

Figure 4.2 Schematic diagram of the sealed heating system

(a) *mCHP BoilerMate^{A-CLASS}* is only available for sealed heating systems and the schematic arrangement of a sealed heating system is shown in figures 2.3 and 4.2.

(b) *Model selection:* We recommend that the method for heat loss calculations, radiator and boiler sizing contained in BS 5449:1990 is used to calculate the design heat loss of the dwelling. This together with selection data in table 3.3 and the heating power output of the mCHP unit should be used to determine the suitability of the proposed system combination for the dwelling. The allowance for hot water shown in Table 3.2 should be added to the calculated requirement for space heating.

(c) *Design:* The installation must comply with the requirements of BS 6798 and BS 5449. To suit conventional radiator based central heating systems, the appliance will normally provide the same flow temperatures as a conventional gas/oil fired boiler system. Therefore normal procedures for sizing heating circuit network and radiators should be used.

The pump head available for space heating and mCHP hydraulic circuits is shown in figures 3.3 and 3.4. The appliance connection details are shown in figure 3.2 and table 3.1 in the technical specification section 3.

If the appliance is at the highest point of the system, a manual air vent is provided on the appliance. However if any point of the heating system is higher than the appliance, then an air vent must be fitted at the highest point in the system.

At least one flushing point should be fitted at the lowest point in the system to enable the system water to be adequately flushed during commissioning.

(d) *Frost protection:* If it is necessary, to protect the system installed in unheated spaces (e.g. garage, outhouse and ventilated roof space), a frost thermostat(s) must be fitted and wired as shown in sections 5 of this manual. Before fitting the frost protection, the mCHP manual should also be consulted.

(e) *User controls:* The mCHP BoilerMate²⁰⁰⁰ models are supplied with a factory fitted 1-channel programmer and the room thermostat must be wired back to the appliance (see section 5).

To meet the requirements of Building Regulations for a boiler interlock it is recommended that the radiator in the area where the room thermostat is installed should be fitted with lock shield valves on both connections.

(f) *Plastic pipework:* All the recommendations with regard to pipework systems in this manual are generally based on use of BS/EN Standard copper pipework and fittings. However plastic pipework can be used in place of copper internally as long as it is recommended by the manufacturer and installed fully in accordance with their recommendations. We always recommend the barrier plastic pipework for these systems.

It is important that if the system is to be installed using plastic pipework then ensure that it is designed and sized for plastic pipework. This is particularly important in relation to use of push fit connections when using the optional flexible hose kits (See Installation and Wiring section of this document).

(g) *F & E cistern:* The cistern can be fitted up to 10m above the base of the appliance i.e. the maximum static pressure in the appliance must not exceed 1.0 bar. The water level in the F & E cistern should be at least 250mm above the highest point of the circuit from the mCHP unit.

(h) *Overflow pipe:* The overflow/warning pipe should be in 20mm internal diameter pipe of suitable material for use in heating systems in accordance with BS 5449 (such as copper). It should have continuous fall and discharge in a conspicuous external position. It should not have any other pipework directly branched into it.

(i) *Cold feed and open vent:* The BoilerMate thermal store acts as the neutral point of the system. The open vent (22mm copper) and the cold feed/expansion pipe (15mm copper) are provided in the F & E cistern as an assembly and should be installed in accordance with instructions provided.

4.3 mCHP CIRCUIT DESIGN

When designing the hydraulic circuit between the mCHP unit and the BoilerMate, as well as this manual, the mCHP unit manufacturers instructions should be followed. The characteristics of the pumps fitted to the BoilerMate are given in figures 3.4 and 3.5.

The BoilerMate thermal store acts as the neutral point of the system and therefore this circuit should be designed bearing in mind that the open vent and cold feed/expansion pipes are taken from the BoilerMate.

5.0 INSTALLATION AND WIRING

5.1 SITE REQUIREMENTS

- (a) The appliance is designed to be installed in an airing/cylinder cupboard on the 100mm high plinth supplied with the appliance and the minimum relevant dimensions are provided in section 3. The minimum dimensions shown in figure 3.2 and Table 3.1, allow for the passage/connection of pipes to the appliance from any direction as long as the appliance is installed on the base provided. If the installation base is not used, extra space may be needed to allow connection to the appliance pipework.
- (b) A suitable location will normally be needed for the separate feed and expansion cistern. This will often be at a high level in the cupboard housing the BoilerMate. The appliance CF & OV pipework assembly has been designed so that the cistern can be fitted on top of the BoilerMate appliance if required. The dimensions and clearances are provided in section 3. The location will need to provide a suitable route for the cold feed and expansion pipe as well as the open safety vent pipe and also a suitable route for the warning overflow pipe.
- (c) Because of ease of installation it is recommended that the cupboard construction is finished and painted before installation of the appliance. The cupboard door can be fitted after the installation.
- (d) If the unit needs to be stored prior to the installation, it should be stored upright in a dry environment and on a level base floor. For handling instructions please see page 4 of this manual.
- (e) The floor of the cupboard must be level and even and capable of supporting the weight of the appliance when full. Also installation and maintenance access is needed to the front of the appliance and above the F & E cistern. See Technical Specifications (section 3) for further details.
- (f) The appliance is designed to operate as quietly as practicable. However some noise from pumps etc. is inevitable in any heating system. This will be most noticeable in cupboards formed on the bulkhead or at the mid span of suspended floor. In these cases the situation can be improved by placing the appliance on a suitable sound deadening material.
- (g) When using push fit connectors with the flexible hose kits it is important to check that they are compatible. We currently recommend push fit connectors from the following manufacturers. The installer must check and confirm the suitability of any other types of push fit connectors.
- Hepworth –Hep₂O BiTite
 - John Guest – Speedfit
 - Yorkshire – Tectite
- (h) The cupboard will normally be at marginally higher temperature than in a conventional system and the design of the door and the cupboard will need to take this into account. However no ventilation is normally required to the cupboard.
- (i) A 230V/50Hz electrical supply must be available which is correctly earthed, polarized and in accordance with the latest edition of the IEE regulations for electrical installations BS 7671. The connection must be made using a double-pole linked isolator with contact separation of 3mm in both poles which is located within 1m of the appliance and it must only serve the appliance.
- The rating of the electricity supply to the mCHP_BoilerMate must be 6.5kW at 230V ac (See also 3, section 4).
- (j) The location site chosen for installing the mCHP unit must meet the requirements of its manufacturer.

5.2 PREPARING APPLIANCE FOR INSTALLATION

- (a) Details of the recommended positions for the termination of first fix pipework are provided in section 3, figure 3.2a and 3.2b. The pipework can be located or its position checked using the template provided with each appliance. If these have been followed, then the installation is very simple and much quicker than any other system.
- (b) The appliance is supplied shrink wrapped on a timber installation base. Carrying handles are also provided in the back of the casing. The appliance should be handled carefully to avoid damage and the recommended method is shown on page 2. **The manual handling operations will need to comply with the requirements of Manual handling Operations Regulations issued by H.S.E.**

Before installation the site requirements should be checked and confirmed acceptable. The plastic cover and protective wrapping should be removed and the installation base provided with the appliance placed in position.

- (c) The appliance can then be lifted into position in the cupboard on top of the base. The front panel can then be removed by unscrewing the 2 screws and lifting the door up and out, ready for connection of pipework and electrical supplies.
- (d) The feed and expansion cistern support shall be installed ensuring that the base is fully supported and the working head of the appliance is not exceeded (10m maximum). Also the recommended access should be provided for maintenance as shown in section 3.

INSTALLATION AND WIRING 5.0

Figure 5.1 Appliance wiring terminals NO clock option

Note: Details of wiring terminals with programmer fitted as standard are shown in figure 3.6

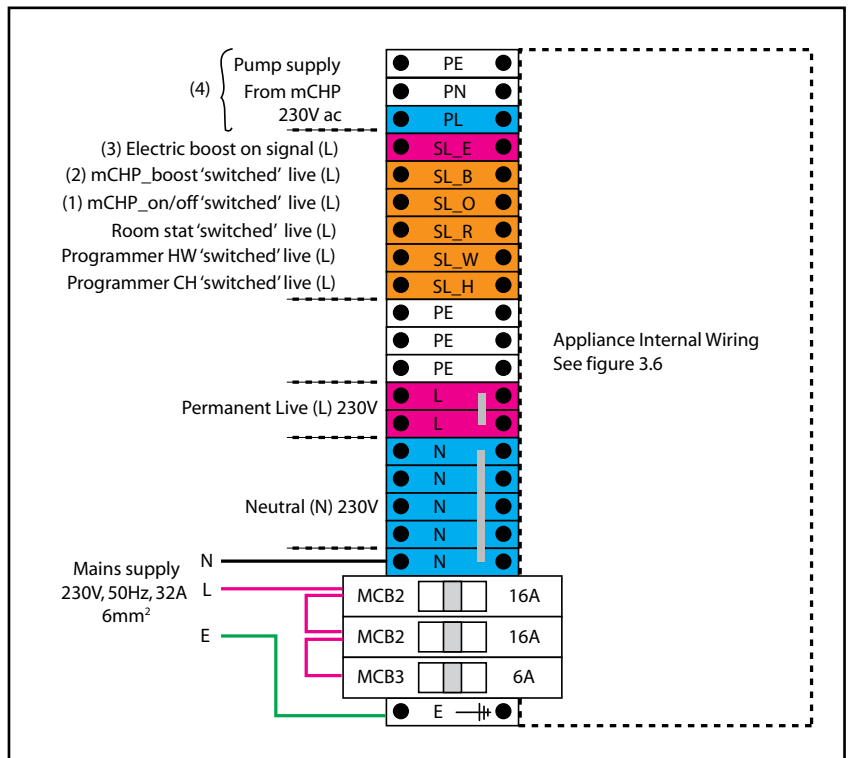
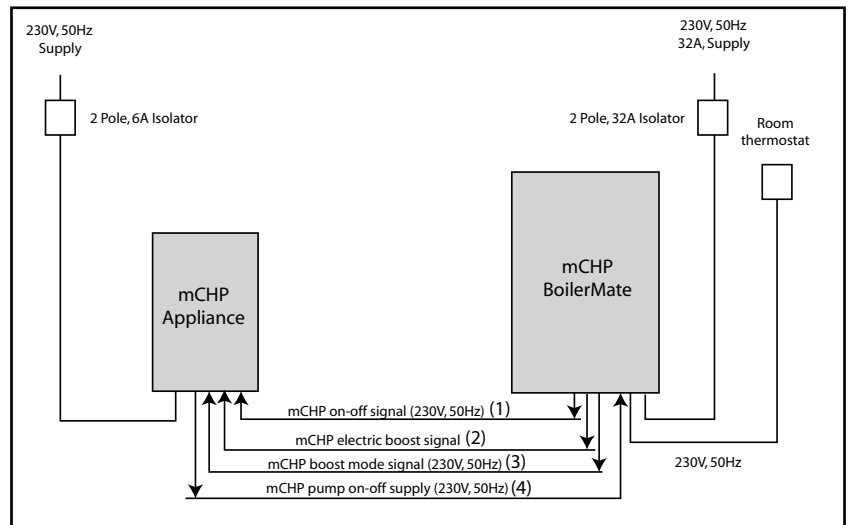

Figure 5.2 Schematic Electrical Wiring Diagram



5.0 INSTALLATION AND WIRING

5.3 PIPEWORK CONNECTION

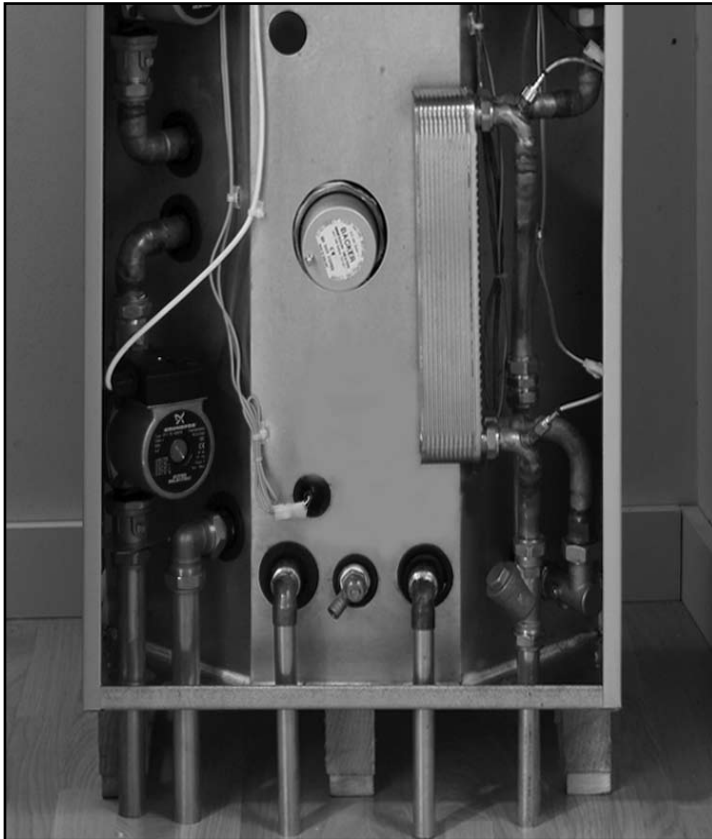

FIG 5.3

(a) The position of the pipework connections is shown opposite in figure 5.3 the connection sizes and dimensions are shown in figure 3.2 and Table 3.1. All connections are also labelled on the appliance. It is essential that the pipework is connected to the correct connection.

(b) If using pushfit connections with the flexible hose kits, it is important to check that they are compatible. Written approvals have already been obtained for:-

- Hepworth – Hep₂O BiTite
- John Guest – Speedfit
- Yorkshire – Tectite

However similar assurances cannot be obtained for Polypipe fittings and therefore we can not recommend their use.

(d) All factory made joints should be checked after installation in case they have been loosened during transit.

(e) The fittings for the feed and expansion cistern should be installed following the instructions provided by the manufacturer in a position to suit the particular location and the cistern fitted on its support base. The cold feed/expansion and safety open vent should be installed between the appliance and the feed and the expansion cistern.

NOTE: 2 F&E cisterns are provided with the 235 model. The ballvalve should not be fitted in the same cistern as the cold feed connection and the position of these and the interconnecting pipework should be arranged to reduce the possibility of stagnant pockets of water in the cisterns.

(f) It is normally envisaged that the feed and expansion cistern will be located in the same cupboard as the BoilerMate itself to maintain dry roof space. However if it is necessary to locate the cistern in the roof space (or on a higher floor) the cold feed/open vent pipework and the cistern will need to be adequately insulated and protected against frost damage.

(g) No valves should be fitted in the safety open vent which must be a minimum of 22mm copper pipe or equivalent.

(h) The overflow/warning pipe shall have a continuous fall, be fitted to discharge clear of the building and be sited so that any overflow can be easily observed. It shall also be installed in a size and material suitable for use with heating feed and expansion cisterns in accordance with BS 5449 and should not have any other connections to it.

(i) **NOTE:** Combined feed and open vent pipe arrangement must not be used.

5.4 ELECTRICAL WIRING

The appliance circuit diagram is shown in figure 3.6 and the external wiring terminal details are shown in figures 5.4 and 5.5. All external controls and equipment must be wired to these terminals. The mCHP unit manufacturers wiring instructions should be read in conjunction with this manual before commencing the wiring process.

5.4.1 GENERAL

- (a) This appliance **MUST BE EARTHED**. The wiring must comply with the current I.E.E Requirements for Electrical Installations (BS 7671) and the requirements of the local electricity utilities.
- (b) It is the responsibility of the competent electrical installer to use the details in this manual with the latest British Standards. All external wiring to the mCHP unit, programmer and the room thermostat must be in accordance with the latest I.E.E. Wiring Regulation, and any local regulations which may apply.
- (c) The appliance has an integral either 6kW electric backup/boost heater and therefore the supply must be rated at minimum 32A (at 230V~,50Hz) as discussed in section 3 of the manual.
- (d) All electrical wiring to the appliance should be secured to prevent the wires/cables touching any hot surfaces inside and outside the appliance case.
- (e) The mCHP appliance generates heat and electricity. Therefore there must be separate supplies and isolators for the BoilerMate and the mCHP unit. These isolators must provide complete electrical isolation for the system, via a fused double pole isolators with a contact separation of at least 3mm in both poles.
- (f) In the event of an electrical fault after installation of the appliance, preliminary electrical checks must be carried out i.e. Earth Continuity, Short Circuit, Polarity, and Resistance to Earth.

5.4.2 WIRING THE APPLIANCE (BOILERMATE)

- (a) Ensure that the electricity supplies to both the BoilerMate and the mCHP unit are switched off before commencing electrical work.

The mCHP BoilerMate is supplied with a pre-wired 2m long twin + E cable rated at 32A. Connect this cable to the local BoilerMate isolator (See figure 5.4)

- (b) When the thermal store requires heating, the BoilerMate controller will generate a 230V ac on/off signal at terminals labelled 'SL-O' and 'N'.

These terminals should be wired to the appropriate connection/terminals of the mCHP unit as per manufacturer's installation manual. The wiring arrangement for the WisperGen mCHP unit is shown in figure 5.4.

- (c) If the heat energy supplied to the thermal store is not sufficient when the mCHP unit is running in normal mode, then the BoilerMate controller will generate a 230V ac boost signal at terminals labelled 'SL-B' and 'N'.

If necessary these terminals should be wired to the appropriate connection/terminals of the mCHP unit as per manufacturer's installation manual. The wiring arrangement for the WisperGen mCHP unit is shown in figure 5.4.

- (d) If the mCHP unit has electrical output (230V ac) for controlling the mCHP/System pump. Then these output terminals must be wired to the BoilerMate terminals

labelled 'PL', 'PN' and 'PE'. This will transfer the control of the pump from BoilerMate to the mCHP unit. The wiring arrangement for the WisperGen mCHP unit is shown in figure 5.4.

- (e) mCHP_BoilerMate is supplied with a single channel heating and hot water programmer. Therefore only room thermostat wiring is required. The room thermostat wiring should be connected to terminals 'L2', 'SL-R', 'N' and 'E' as shown in figure 5.4
- (f) The remote 2-channel programmer and the room thermostat can be wired to the mCHP BoilerMate with 'No clock' option as shown in figure 5.5.
- (g) **DO NOT SWITCH ON** the electricity supply to the appliance at this stage. Before switching on the supply ensure that the system is full of water and commissioned as per section 6 of this manual and the mCHP unit manufacturer's manual.

5.0 INSTALLATION AND WIRING

Colour Legend	
Brown	Br
Blue	Bl
Black	B
Grey	Gry
Green / Yellow	G / Y

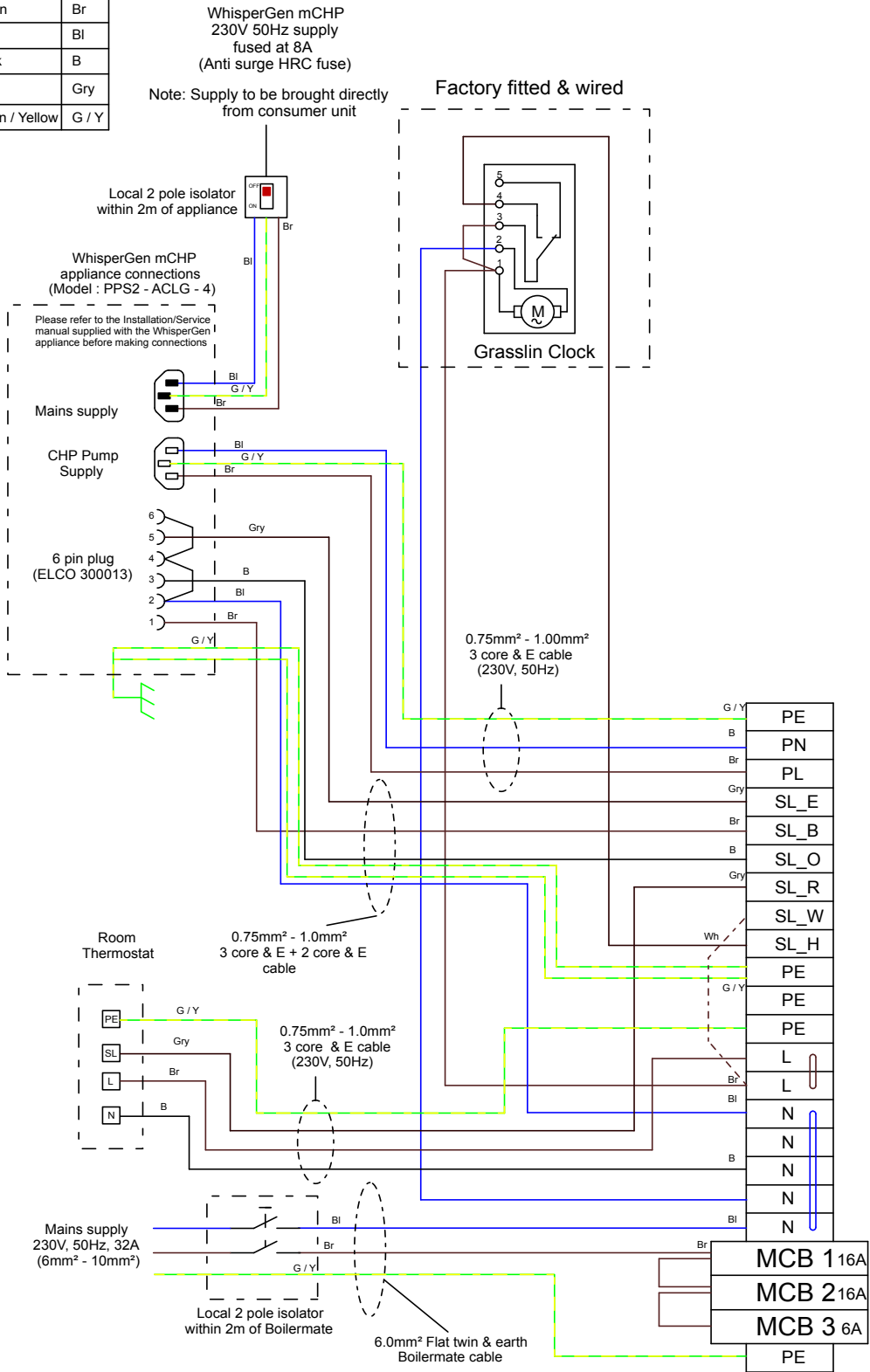
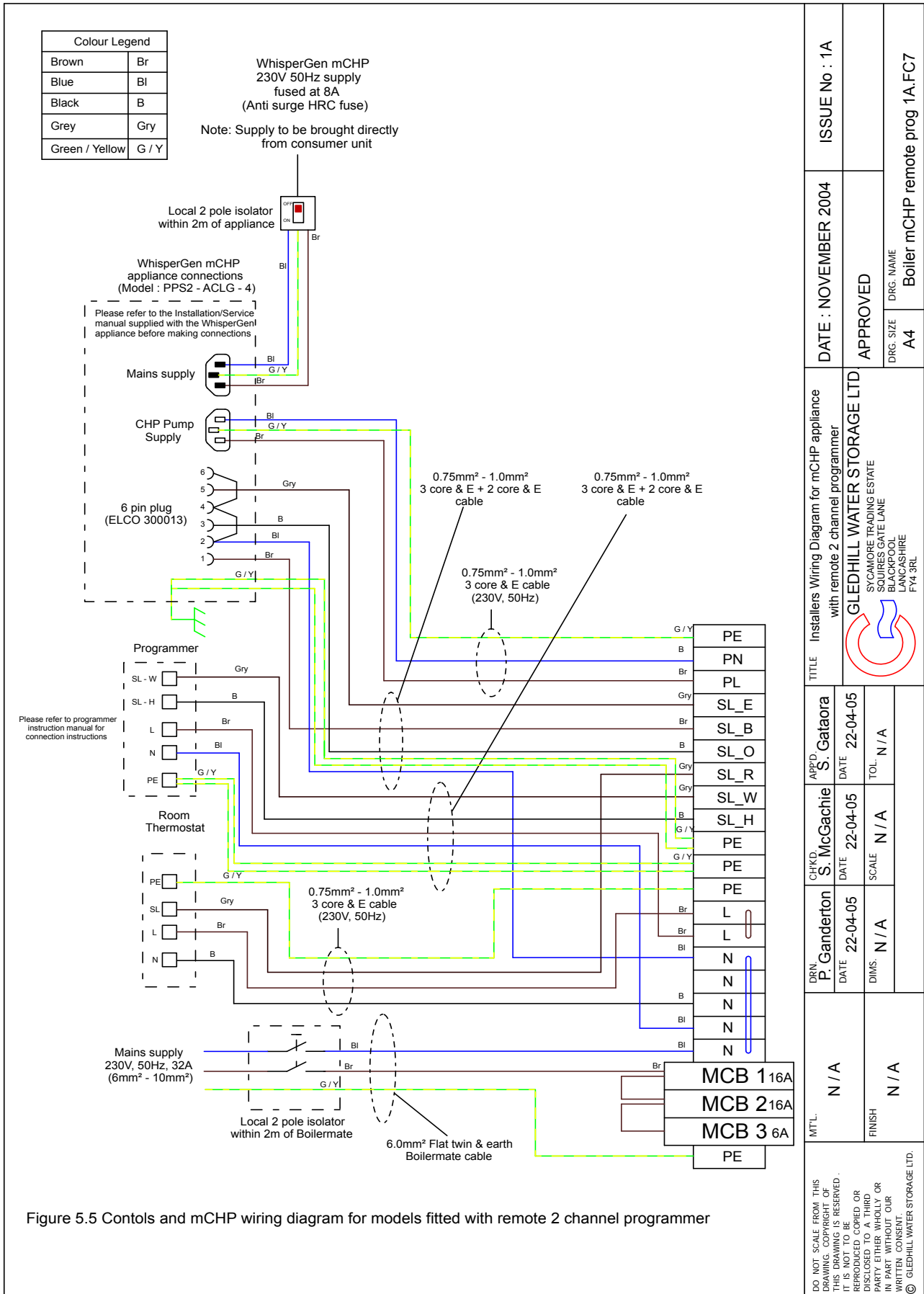

Figure 5.4 Contols and mCHP wiring diagram for models fitted with programmer

ISSUE No : 1A	DATE : NOVEMBER 2004	APPROVED	DRG. NAME A4	Boiler mCHP prog 1A.FC7
Installs Wiring Diagram for mCHP appliance with factory fitted programmer	GLEDHILL WATER STORAGE LTD	SYCAMORE TRADING ESTATE SOURCES GATE LANE BLACKPOOL LANCASHIRE FY4 3RL		
APPR'D S. Gataora	DATE 22-04-05	TOL. N/A		
CHK'D S. McGachie	DATE 22-04-05	SCALE N/A		
DRN P. Ganderton	DATE 22-04-05	DIMS. N/A		
MTL. N/A	FINISH N/A			
DO NOT SCALE FROM THIS DRAWING. COPYRIGHT OF THIS DRAWING IS RESERVED. IT IS NOT TO BE REPRODUCED, COPIED OR DISCLOSED TO A THIRD PARTY EITHER WHOLLY OR IN PART WITHOUT OUR WRITTEN CONSENT. © GLEDHILL WATER STORAGE LTD.				

INSTALLATION AND WIRING 5.0



ISSUE No : 1A	
DATE : NOVEMBER 2004	APPROVED
DRG. NAME Boiler mCHP remote prog 1A.FC7	
DRG. SIZE A4	
TITLE Installers Wiring Diagram for mCHP appliance with remote 2 channel programmer	
GLEDHILL WATER STORAGE LTD SYCAMORE TRADING ESTATE SQUIRES GATE LANE BLACKPOOL LANCASHIRE FY4 3RL	
DRN. P. Ganderton	CHKD. S. McGachie
DATE 22-04-05	DATE 22-04-05
DIMS. N/A	SCALE N/A
APP'D. S. Gataora	DATE 22-04-05
TOL. N/A	
MTL. N/A	FINISH N/A
DO NOT SCALE FROM THIS DRAWING. COPYRIGHT OF THIS DRAWING IS RESERVED. IT IS NOT TO BE REPRODUCED COPIED OR DISCLOSED TO A THIRD PARTY EITHER WHOLLY OR PARTIALLY WITHOUT OUR WRITTEN CONSENT. © GLEDHILL WATER STORAGE LTD.	

6.0 COMMISSIONING

6.0 COMMISSIONING

- (a) It is essential that the system functions properly for optimum performance. To achieve this, the heating and the hot water system should be commissioned in accordance with the good practice and generally with the requirements of BS 6798, BS 5449 and BS 7593. Full details of the requirements are given in PAS 33:1999 under section 10 Commissioning.
- (b) **WARNING:** Do not attempt to start this appliance unless the appliance and the heating system have been filled with water and thoroughly vented.
- (e) Heat the system to full operating temperature and check for water leaks and rectify if necessary. Flush the system again until it is clean.
- (f) Refill the system and add Fernox MB1 Protector to the system ensuring that the system is fully vented.

6.1 INITIAL SYSTEM FILLING

- (a) Open the cold water stop cock on the inlet to the appliance and allow water to flow through the F & E cistern/appliance to all the domestic water taps. Ensure all air is vented and there are no leaks.
- (b) Check and adjust if necessary the air pressure in the heating expansion vessel.
- (c) Fill the sealed heating system in the normal way through the temporary filling loop to the pressure required.
- (d) Vent as necessary and then check the whole of the primary heating and domestic hot and cold distribution system for leaks,
- (e) When the system is full check if the water level in the F & E cistern is correct and adjust the ball valve if necessary.
- (f) Check the functioning of the overflow/warning pipe and regulate the service valve so that in a fault condition, the warning/overflow pipe can carry the maximum water supply into the F&E cistern.

6.2 CLEANSING AND WATER TREATMENT

6.2.1 WATER TREATMENT

Although the BoilerMate has no special water treatment requirements, the radiators and other parts of the system will benefit from the application of scale and corrosion inhibitor such as the 'Fernox Superfloc' cleaning agent and Fernox MB1 protector.

The correct use of cleaning agent and of the correct strength of inhibitor is essential for the efficient and long life of the complete system. Failure to do this correctly will result in premature corrosion of the boiler/blocking of the waterways and neither of these situations will be covered by the appliance warranty.

The correct quantities of cleaning and treatment agents should be determined from manufacturer's instructions.

- (a) Ensure that all cleansing/treatment of the heating system is carried out fully in accordance with the instructions provided by Fernox.
- (b) The water system must be thoroughly flushed out, initially with cold water and ensuring that all valves are fully open.
- (c) Refill the system to normal working pressure. Examine for water leaks. Rectify if necessary.
- (d) Add Fernox Superfloc Cleansing Agent to ensure that all flux residues and installation debris are removed from the system.

6.2.2 POWER FLUSHING/CLEANING OF THE HEATING SYSTEM

- (a) When carrying out the work, always comply fully with the manufacturers' instructions for the power flushing equipment.
- (b) We would always recommend that the BoilerMate is isolated from the heating system being cleaned. If in any doubt, please consult our Technical Help line.

6.2.3 CLEANSING HOT & COLD WATER SYSTEM TREATMENT

- (a) Fully flush and if necessary chlorinate the hot and cold water system in accordance with the recommendations in the Model Water Bylaws and BS 6700.

6.3 COMMISSIONING mCHP UNIT & BOILERMATE

- (a) Check that the mCHP BoilerMate front panel switch is in 'On' position and the mode switch is in the 'normal' position.
- (b) The mCHP unit will not start i.e there will be no 240V ac start signal at BoilerMate terminal 'SL-O' until:-

- The heating clock calls for heating indicated by display segment V1.1 being on (see figure 6.2)
- Store sensors are calling for heat indicated by display segments H1.1 and H1.2 being on (see figure 6.2)

- (c) Commission the mCHP unit as per manufacturer's instructions and ensure that the flow temperature is set at maximum i.e. greater than 77°C.

After the mCHP start sequence, which could take 8 - 12 minutes, the thermal store will begin to heat up and the store temperature can be read from the display (see section 3.6)

- (d) Check that the mCHP boost mode and the auxiliary electric heater is functioning correctly. This can be done when the mCHP is running and the central heating is on by removing the top store sensor, S6 from the pocket i.e. simulating that the store is not heating at correct rate.

This will be indicated by controller display segment H2.2 being on (See figure 6.2). When mCHP boost is active, there will be a 230V ac signal at terminal 'SL-B' in the BoilerMate.

After this test, **ensure that the sensor is inserted and secured into the pocket.**

- (e) To check manual electric backup heating, move operation switch on front panel display from 'normal' to 'switch' position. The electric backup operation can now be observed.

- (b) Set heating clock to continuous and ensure that the room thermostat is calling for heat. This will be indicated by display segments V1.3 and V1.4 being on respectively. The BoilerMate controller will now:-

- Switch on the central heating pump and this will be indicated by display segment H2.2 being lit.

- (c) With flow to the central heating circuit, bleed every radiator and pipework high points until air or air/water mix has been removed.

- (d) Wait until the heating circuit has reached its normal mean temperature of approximately 75°C before balancing the system in the usual way to achieve a temperature drop between 10 and 12°C.

- (e) Ensure that the system has been flushed and treated.

- (f) Set the clock as per manufacturer's instructions supplied with the appliance and ensure that the room thermostat and appliance instructions are left with the user.

6.4 COMMISSIONING SPACE HEATING

- (a) The central heating is best commissioned when the store is hot and therefore should be carried out after procedure 6.3.

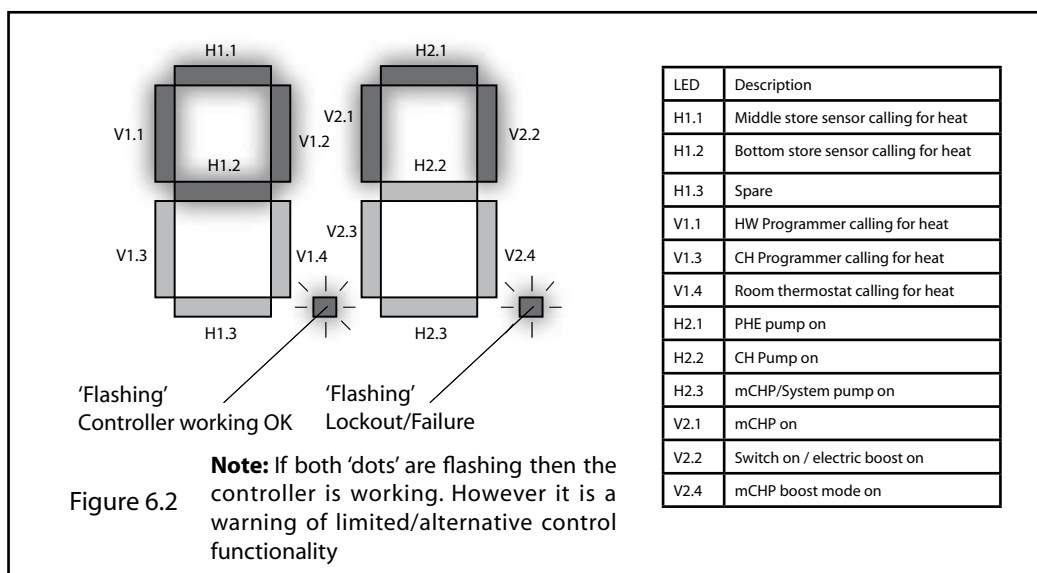

6.5 COMMISSIONING DOMESTIC HOT WATER SYSTEM

- (a) When the store is hot, open a hot water tap nearest to the appliance at approximately 6 litres/minute. After about 2 – 3 seconds, the plate heat exchanger pump will start. This is indicated by on main PCB display by display segment H2.1 (see figure 6.2).
- (b) Record the hot water outlet temperature in the 'Benchmark' logbook. Close this tap and open the hot bath tap at maximum flow rate and record the flow rate and the hot water temperature in the 'Benchmark' logbook.
- (c) Close the hot water tap(s) and after few seconds, the plate heat exchanger pump will stop running and display segment H2.1 will switch off (see figure 6.2).

6.6 COMMISSIONING THE STORE CHARGE CONTROL SET POINTS

The operation of the mCHP unit is controlled by the BoilerMate controller. Normally factory default set points will control the system efficiently. These set points can be changed by connecting the PC to the controller and running the appropriate software.

6.7 HAND OVER TO USER

- (a) Explain the system and the BoilerMate appliance controls to the user.
- (b) Explain how to operate the heating and hot water controls to the user. This should include setting 'on' and 'off' times and the room temperature on the programmable room thermostat and the use of thermostatic radiator valves.
- (c) Advise on mCHP operation and maintenance advised in mCHP manual.
- (d) Explain how to select the emergency backup electric boiler 'switch operation' - if there is a failure of the mCHP.
- (e) Handover appliance and room thermostat user instructions and put the completed "Benchmark" logbook and the appliance instruction manual in the pocket on the inside of the appliance front panel.
- (f) **DON'T** place any clothing or other combustible materials against or on top of this appliance.

7.1 ANNUAL SERVICE

No annual service of mCHP BoilerMate A-Class is necessary. However, if required, the operation of the controls and a hot water performance test can be carried out when servicing the mCHP unit to prove that the appliance is working satisfactorily and within the specification.

For mCHP unit service requirements please refer to the mCHP manual and recommendations.

Note: Service details must be recorded in the Benchmark logbook.

7.2 CHANGING COMPONENTS

Free of charge replacement components for the faulty components are available from Gledhill during the in-warranty period (normally 12 months).

After this the spares can be obtained direct from Gledhill using the 'Speed Spares' service or through any of the large plumbers merchants/specialists heating spares suppliers. Short parts list is shown in table 7.1.

Help and advice is also available from the Technical Help Line on 08449 310000.

However all components are readily accessible and can be changed quickly and easily by the installer using common plumbing and electrical practices.

Table 7.1 Specification of main components and Parts List

	Description	Supplier & model	Part number	Stock Code
1	PHE pump	Grundfos, UPR 15-50 (modulating)	59505432	GT089
2	Plate heat exchanger (PHE)	SWEP, 24 Plate heat exchanger	E8T/24	GT017
3	PHE pump isolating valve - inlet	Martin Orgee, 90° valve	7308123	GT135
4	PHE Pump isolating valve - outlet	Martin Orgee, Straight valve with NRV		GT133
5	CW inlet Y-line strainer			XB314
6	Boiler pump	Grundfos, UPS 15-60 (1½" - standard)		XB241
7	Central heating pump	Grundfos, UP 15-60 (1½" modulating)	59505432	GT089
8	Boiler pump isolating valves	Vemco, 22mm ball type (Inlet & Outlet)		XB121
9	Central heating pump isolating valves	Martin Orgee, 90° valve - INLET Martin Orgee, Straight valve - OUTLET	7308123 ---	GT135 GT133
10	2 x 3kW switch immersion heater	Backer		
11	Main PCB controller	Pijenburg, 147/3GS controller	147/3GS	GT103
12	Bottom store sensor	Tasseron, Single sensor	TSK10B4	GT198
13	Middle store sensor	Tasseron, Single sensor	TSK10B4	GT198
14	Top (OHT) sensor	Tasseron, Duplex sensor	TSK11B4	GT199
15	Front panel display	RH Technical, Membrane overlay		
16	Front panel display wiring harness	RH Technical, Membrane harness		
17	Internal fuses/circuit protection	Control circuit: 1 x 6A MCB Switch circuit: 2 x 16A MCB		
18	Switch contactor	Telemecanique, 1 x 25A contactor	GC2520-M5	XB014
19	DIN Rail terminals	Wago, Part of DIN rail assembly	51002318	XB140
20	Complete DIN rail assembly	Wago, Bespoke terminal & components		NSI
21	Complete wiring harness			
22	On-Off switch (part or panel)	Arcoelectric, Green illuminated rocker switch	C5503-ALNAK	CA006
23	Clock	Grasslin Electromechanical		XB215
24	Pump relay			

APPENDIX A

WATER SAVINGS

WATER RELATED COSTS CAN BE REDUCED BY GOOD PLUMBING PRACTICE.

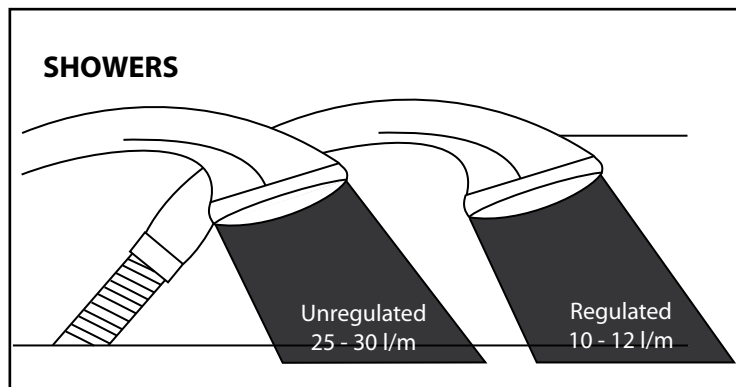
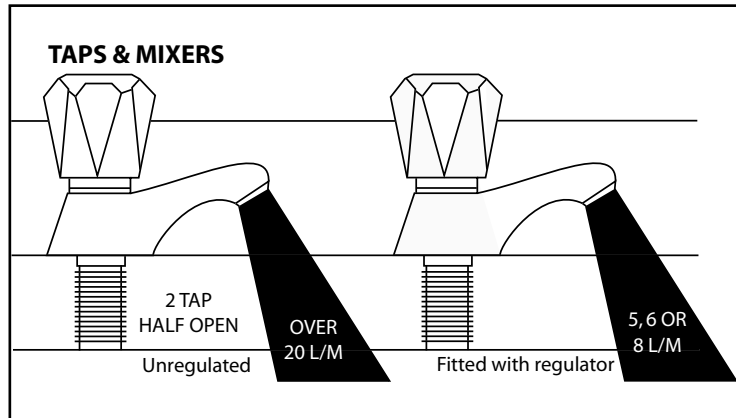

Vast quantities of water are needlessly run off to waste due to Taps, Mixers and Showers discharging flow rates far in excess of the rates required for them to perform their duties.

The contrasting flow rates shown on this leaflet clearly illustrate the savings that can be made whilst still providing a good performance.

British made Aquaflow Regulators provide constant flow rates by automatically compensating for supply pressure changes between 1 bar & 10 bars.

To facilitate installation into the wide range of plumbing equipment which is encountered in the U.K, Four Fixing Options are available:-

OPTIONS FOR SHOWERS

1. MXF "DW" Range - For fitting behind Fixed Shower Heads or onto Flexible Hoses for Handshowers (preferably onto the inlet end when lightweight hoses are used).
2. Compression Fitting Range. "In Line" regulators as in Option 4 for Taps & Mixers.

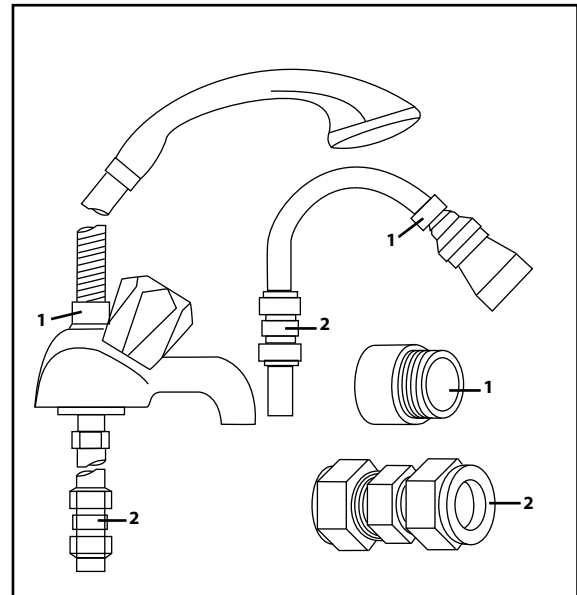

4 FIXING OPTIONS FOR TAPS & MIXERS

1. MK Range - Combined Regulators & Aerators for screwing onto Taps & Mixers with internal or external threads on their noses. Anti Vandal models also available.
2. MR05-T Range - Internal Regulators. Push-fit into Tap or Mixer seats. Produced in three sizes - 12.5mm (BS1010), 12mm & 10mm, Flangeless models also available for Taps with Low Lift washers.
3. MXF Standard Range - Screw on tail models for Taps & Mixers. Fix onto the tails before fitting the tap connectors. Available in 3/8", 1/2", 3/4" and 1" BSP.
4. Compression Fitting Range - "In Line" regulators housed in 15mm & 22mm CXC Couplers & Isolating Valves. "UKWFS listed by the Water Research Centre. Isolation valves available for slotted screwdriver operation or with coloured plastic handles. Now available also in plastic bodied push-fit couplers & valves.

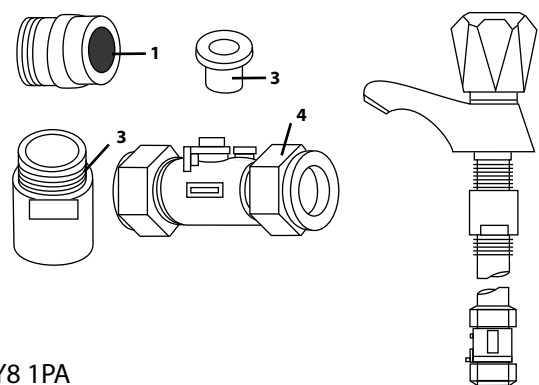

Information by courtesy of

AQUAFLOW REGULATORS LTD

Haywood House, 40 New Road, Stourbridge, West Midlands DY8 1PA
TELEPHONE (01384) 442611 FAX: (01384) 442612

MANIFOLDS

Manifold type: 1 - Stock Code MIP 050 (one bathroom, one en suite shower room, one cloakroom, one kitchen)			
Flow regulator (litres/minutes)	Terminal fitting	Hot water manifold outlets Quantity	Cold water manifold outlets Quantity
18	Bath tap	1	1
9	Hand basin	3	3
12	Kitchen sink	1	1
9	Toilet cistern	None	3
9	Shower	1	1
12	Washing machine	1	1
9	Dishwasher	None	1
	Total	7	11

Two sets of manifolds are available as an optional extra. Each set comprises a separate hot and cold water manifold. Both are provided with a 22mm inlet connection located centrally. All outlet connections are 15mm compression. The centre to centre dimension of each branch is 55mm.

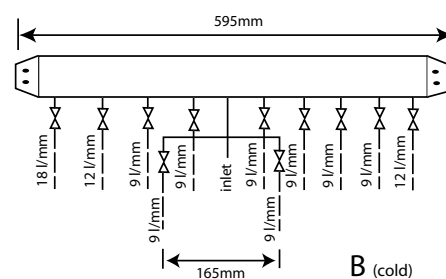
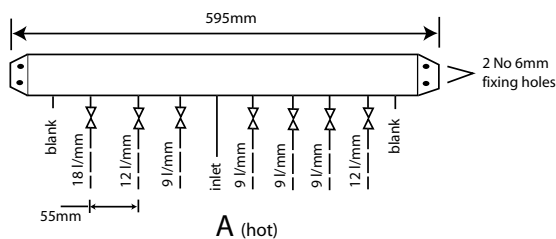

Manifold type: 2- Stock Code MIP 060 (two bathrooms, one en suite shower room, one cloakroom, one kitchen, one utility room)			
Flow regulator (litres/minutes)	Terminal fitting	Hot water manifold outlets Quantity	Cold water manifold outlets Quantity
18	Bath tap	2	2
9	Hand basin	4	4
12	Kitchen sink	2	2
9	Toilet cistern	None	4
9	Shower	1	1
12	Washing machine	1	1
9	Dishwasher	None	1
	Total	10	15

The arrangement of each manifold is supplied as shown. This provides the best balance of flows but the flow regulators/duty of each branch can be changed if required as long as a reasonable balance is maintained. If it is necessary to change or clean the flow regulator this can be done without needing to drain the system by closing the valve and removing the screwed cover below the white plastic cover.

The manifolds are designed to be used with plastic pipework and are supplied complete with isolation valves and flow regulators on each branch. They would normally be installed in the same cupboard as the thermal storage appliance (as shown below) but can be installed in another cupboard close to the appliance if required.

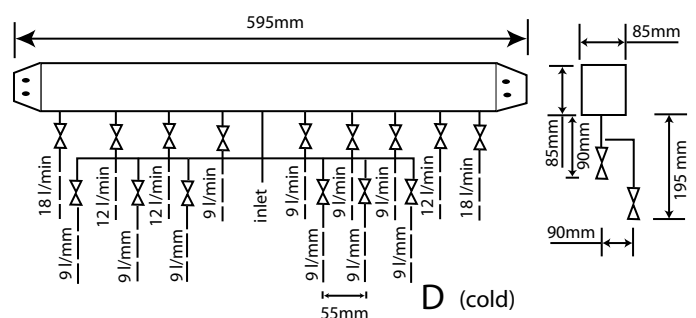
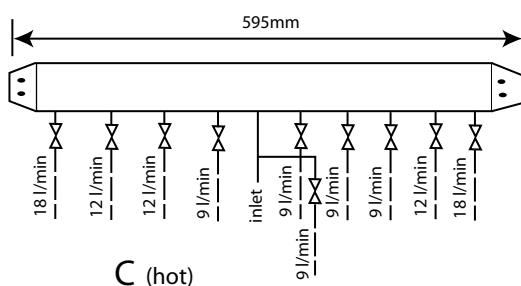

APPENDIX B

An optional location where cupboard space is tight



The pressure loss through a flow regulator at the designated flow rate is about 1.8 bar. Therefore for the flow regulator to control the flow rate at pre-set level, the inlet pressure must be greater than 1.8 bar. If the inlet pressure is lower, the flow rate will be correspondingly less than the pre-set values.

The maximum equivalent pipe lengths from the manifold to the terminal fittings can be estimated from the above information and the resistance characteristics of the pipes. The examples presented below are for 15mm copper pipe in table 1 and for plastic pipework in table 2.



The preferred solution where space will allow

Table 1: Maximum equivalent pipe length in 15mm copper

Inlet pressure (bar)	Maximum equivalent length of pipe (m)		
	@ 9 l/m	@ 12 l/m	@ 18 l/m
2.0	25	10	5
2.5	75	30	15
3.0	150	60	30

Table 2: Maximum equivalent pipe length in plastic pipe

Inlet pressure (bar)	Maximum equivalent length of pipe (m)		
	@ 9 l/m	@ 12 l/m	@ 18 l/m
2.0	1.5	15mm : 10	15mm : 4.5 22mm : 40
2.5	3.0	15mm : 20	15mm : 9.0 22mm : 80.0
3.0	4.5	15mm : 30	15mm : 13.5 22mm : 120

APPENDIX B

The size of the distribution pipes supplying the manifold should be calculated using the method set out in BS 6700. A typical diagrammatic arrangement of a system using Manifold Type 1 is shown below. This is only meant to show the principles involved and the actual connection of fittings to the manifold will need to suit the arrangements shown on page 35.

Note 1 - If it is proposed to fit chemical water treatment such as a water softener this should be fitted in this location and the cold water branch in the sink should be branched off the cold water main prior to the treatment device instead of the cold water manifold.

Any other isolating/control valves and backflow protection devices should be provided as necessary to comply with the Water Regulations.

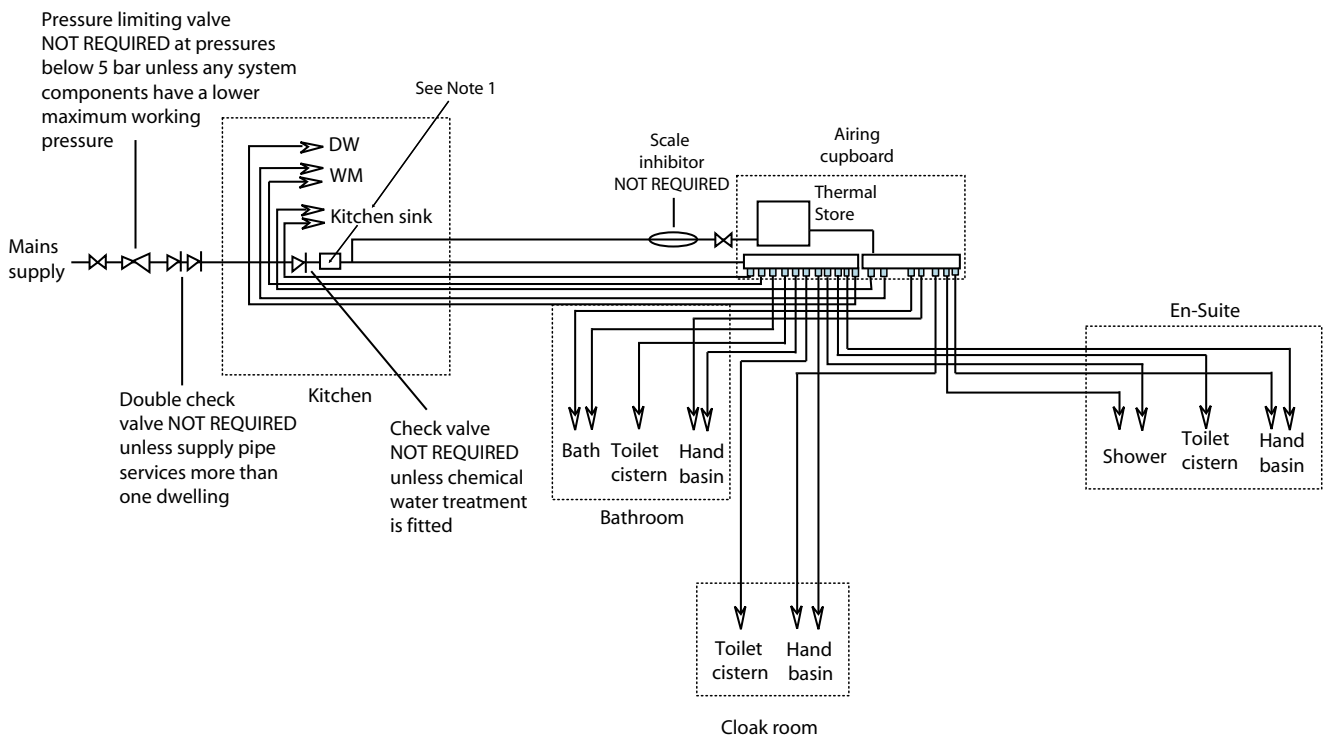



2 Inhibitor (Corrosion & scale protection of primary heating circuit)

On filling the heating system and before the boiler is fired up, it is important to ensure the system water is treated with a suitable corrosion inhibitor, in accordance with the boiler manufacturer's instructions.

Since the concentration of inhibitor present in a system can become diluted, for a number of different reasons, the system should be checked annually and re-treated as required, or after every full or partial drain-down. A water treatment manufacturer's test kit may be used to check the correct concentration of inhibitor in the system.

Where recommended by a boiler manufacturer, a 'physical corrosion protection device' may be fitted in the primary pipework in accordance with the boiler manufacturer's instructions.

The Benchmark log book should be completed indicating the date and details of any of the above products added and a permanent label should be fixed to the system in a prominent location.



3 Scale protection (Domestic hot water service)

Where a combi boiler and/or a hot water storage vessel is installed in areas where the mains water can exceed 200ppm Total Hardness (as defined by BS 7593: 1993 Table 2) a scale reduction device should be installed, in accordance with the boiler manufacturer's instructions.

The levels of water hardness may be measured using a water hardness test kit.

BUILDING REGULATIONS

Completion of the BENCHMARK log book requires that the 'competent person' undertaking the installation and commissioning provide information relating to Cleaning, Inhibitor and Scale Protection. This will demonstrate that the work complies with the requirements of the appropriate Building Regulations.

This Guidance Note is produced on behalf of its members by the Central Heating Information Council. For a full list of members visit www.centralheating.co.uk and for further advice on water treatment contact the following members:

Culligan Sentinel Ferno Salamander Engineering Scalemaster

Heating & Hotwater Information Council, 36 Holly Walk, Leamington Spa, Warwickshire CV32 4LY Tel: 0845 600 2200 Fax: 01926 423284
www.centralheating.co.uk



Benchmark is managed by The Heating & Hotwater Information Council

MANUAL HANDLING OF APPLIANCE PRODUCTS

Description

Manual handling means any transporting or supporting of a load (including lifting, putting down, pushing, pulling, carrying or moving) by hand or bodily force.

Scope

This assessment will cover the largest Appliance, namely ElectraMate, GulfStream, BoilerMate, SysteMate, PulsaCoil, Accolade and Stainless Lite manufactured by Gledhill.

The maximum weight of the largest product in each range is 98kg and the size is 595 x 595 x 2020 mm high.

Main Hazards

Vision may not be clear due to the size of the products. Adopting an incorrect method of lifting may cause injury, attempting to lift these products will require help from others. (Team lifts)

Control Measures

Manual lifting procedure

The lift, key factors in safe lifting are:

- a. **Balance**
- b. **Position of back**
- c. **Positioning of the arms and body**
- d. **The hold**
- e. **Taking the lead for team lifts**

- a. **Balance** - Since balance depends essentially upon the position of the feet, they should be apart about hip breadth with one foot advanced giving full balance sideways and forward without tension. In taking up this position, lifting is done by bending at the knees instead of the hips and the muscles that are brought into use are those of the thigh and not the back.
- b. **Position of back** - Straight - not necessary vertical. The spine must be kept rigid, this coupled with a bent knee position, allows the centre line of gravity of the body to be over the weight so reducing strain.
- c. **Positioning of arms and body** - The further arms are away from the side, the greater the strain on the shoulders, chest and back. Keep elbows close to the body arms should be straight.
- d. **The hold** - Before lifting ensure you have a good hold. Two handles are provided on Appliance products at the top rear side, these allow one or two persons to have a purposely-designed hold at the top of the appliance to ensure easy lifting at the top of the product. Each appliance is supplied with a pallet, which has been attached to the unit via the packaging. The pallet will also allow for one or two persons to get a good hold.

- e. **Taking the lead for team lifts**- As more than one person is required for these products ensure that one person is taking the lead. **This may be you** so ensure that each person that is helping is made aware of the weight and of the items listed within this assessment. Make sure you and any others helping know the route you intend to take that it is clear of any obstructions. Never jerk the load as this will add a little extra force and can cause severe strain to the arms, back and shoulders. If there are steps involved decide on where you will stop and take a rest period. Move smoothly and in unison taking care to look and listen to others helping with the lift. Where possible use a sack truck to move the product over long flat distances, only lift the products when necessary. If in doubt stop and get more help. The unit handles and packaging with the pallet have been designed to ensure that two-four people can assist when lifting up stairs or over longer distance.

Individual capability

Individual capability plays an important part in handling these products. Persons above average build and strength will find it easier and should be in good health. Persons below average build and strength may require more rest periods during the handling process. Pregnant women should not carry out this operation. Persons who are not in good health should seek medical advice prior to commencing any lifting or manual handling operation.

Residual risk

Following the guidelines given above will reduce any risk to injury. All persons carrying out this operation must be fully trained and copies of the specific risk assessment made available for inspection and use in their training process.

Further guidance on Manual Handling can be obtained from the Health and Safety Executive. Manual Handling Operations Regulations 1992.

Gledhill (Water Storage) Ltd

AMD. JUNE 2008

CONDITIONS OF SALE & GUARANTEE TERMS

1. Gledhill (Water Storage) Ltd ("We" or "Gledhills") only do business upon the Conditions which appear below and no other. Unless we so agree in writing these Conditions shall apply in full to any supply of goods by us to the exclusion of any Conditions or terms sought to be imposed by any purchaser. These Conditions of Sale and Warranty Terms override those which are contained on the Invoice Forms and all Sales are now subject to these Conditions of Sale and Warranty terms only.

2. PRICE

Once an order or call off has been accepted the price will be held for three months **but if delivery is extended beyond that period at the customer's request, then we reserve the right to amend the price when necessary.** The company reviews its pricing annually to adjust for changes in our cost base. We reserve the right to alter prices at any time for severe movements in raw materials (mainly copper and steel). If there is to be a change we will give customers at least four weeks notice but anything delivered after that date will be at the revised price. An order may not be cancelled or varied after acceptance without the written consent of the company. Such cancellation or variation shall be subject to such reasonable charges as may be appropriate.

3. SPECIFICATION

The goods are supplied in accordance with the Specifications (if any) submitted to the Purchaser and any additions and alterations shall be the subject of an extra charge. Any goods not so specified shall be in accordance with our printed literature or the literature of any of our component suppliers (subject to any modifications made since publication). If we adopt any changes in construction or design of the goods, or in the specification printed in our literature, the Purchaser shall accept the goods so changed in fulfilment of the order.

4. PAYMENT

The invoice price of goods shall be payable within 30 days of despatch by us of our invoice for the goods or such longer time as may be stated by our quotation or invoice. If we receive payment in full on or before the due date we will allow an appropriate settlement discount except where we have quoted a special net price. If payment is not received in full on or before the due date we shall be entitled in addition to the invoice price to:

- (i) payment of a sum equal to any increase in the copper price supplement applicable to the particular goods sold between the date of receipt of order and the date of receipt of payment in full; and
- (ii) interest on any part of the invoice price unpaid after the due date at the rate of 3% per annum over the base rate for the time being of HSBC Bank plc.

5. TIME

We give estimates of delivery dates in good faith and time of delivery is not nor shall be made of the essence of any contract nor shall we be liable for any loss or damage occasioned by delay in delivery.

6. DELIVERY

We deliver free normally by our own vehicles within 25 miles of any of our manufacturing depots. Delivery to any place more than 25 miles from one of our manufacturing depots may be subject to our quoted delivery charges. We reserve the right to make delivery of goods contained in one order by more than one consignment and at different times. Where a period is agreed for delivery and such period is not extended by our Agreement, the Purchaser shall take delivery within that period. If the Purchaser fails to take delivery, we shall be entitled at the Purchaser's risk and expense to store the goods at the Purchaser's premises or elsewhere and to demand payment as if they had been despatched. Off loading at point of delivery shall be the responsibility of and be undertaken by the Purchaser.

7. SHORTAGES OR DAMAGE

Goods must be inspected before signature of delivery note and any damage, shortage or discrepancy noted on the delivery note and the goods returned on the same vehicle. The buyer must also give us immediate written notice of the damage, shortage or discrepancy so that we may prompt investigation.

8. RETURN OF GOODS

Goods may not be returned to the Company except by prior written permission of an authorised officer of the Company and such return shall be subject to payment by the Purchaser of handling and re-stocking charges, transport and all other costs incurred by the Company.

9. COMPANY LIABILITY AND GUARANTEE

9.1. Subject to the terms of these Conditions of Sale and Guarantee Terms Gledhills provide Guarantees in respect of specific products as set out in this clause.

9.2. Each Guarantee is strictly conditional upon the following:-

9.2.1. Complaints must be given to us immediately, before any action is taken, as responsibility cannot be accepted if repairs or renewals are attempted on site without our written approval.

9.2.2. The unit has been installed in accordance with our installation and service instructions and all relevant codes of practice and regulations in force at the time of installation.

9.2.3. All necessary inlet controls and safety valves have been fitted correctly.

9.2.4. The unit has only been used for the storage of potable water supplied from the public mains.

9.2.5 Where appropriate the unit has been regularly maintained as detailed in the installation and service instructions

9.2.6. Defects caused by corrosion or scale deposits are not covered by any Guarantee.

9.2.7. Where we agree to rectify any defect we reserve the right to undertake the work on our own premises.

9.3. Guarantees are provided in respect of specified goods supplied by Gledhills as follows:-

(a) Domestic and Commercial Open Vented Cylinders and Tanks.

The copper storage vessel is guaranteed for ten years and if it proves to be defective either in materials or workmanship, we will either repair or supply replacement at our option with the closest substitute in the case of any obsolete product to any address in Great Britain.

(i) free of all charge during the first year after delivery by us.

(ii) thereafter at a charge of one-tenth of the then current list price and any copper price supplement and delivery charge during the second year after delivery by us and increasing by a further one-tenth on the second and subsequent anniversary of delivery by us.

(b) Domestic Mains Fed Products [Primary Stores]

The copper storage vessel is guaranteed for five years and if it or any integral pipework as part of the storage vessel assembly proves to be defective either in materials or workmanship, we reserve the right to either repair or supply replacements or the closest possible substitute in the case of any obsolete product and will collect and deliver to any address in England, Wales and Scotland (excluding all Scottish Islands).

(i) free of all charge during the first year after delivery by us.

(ii) thereafter at a charge of one-fifth of the then current list price or any copper price supplement and delivery charge during the second year after delivery by us increasing by a further one-fifth on the second and subsequent anniversary of delivery by us.

(c) Integrated Boiler and Storage Vessel Products and Stand Alone Boilers

In the case of the GulfStream range of products and the Gledhill boiler range of products, Gledhill guarantees the heat exchanger (boiler) for material and construction faults for two years. THE RESPONSIBILITY FOR THE EXECUTION OF THIS GUARANTEE LIES WITH THE INSTALLER.

The guarantee becomes null and void if the appliance is used incorrectly, or in the event of proven negligence or incorrectly implemented repairs **OR FAILURE TO CARRY OUT THE RECOMMENDED INSPECTION/ MAINTENANCE.** The guarantee also becomes null and void if changes are made to the appliance without our knowledge, or if the serial number on the appliance is removed or made illegible.

The annual service must be carried out by a competent installer in accordance with the advice given by Gledhill and using Gledhill approved parts.

(d) Stainless Steel Unvented Cylinders

Gledhill guarantee the components including controls, valves and electrical parts for two years from the date of purchase. IT SHOULD BE NOTED THAT THE FACTORY FITTED TEMPERATURE AND PRESSURE RELIEF VALVE MUST NOT BE REMOVED OR ALTERED IN ANY WAY OR THE GUARANTEE WILL NOT BE VALID. GLEDHILL WILL NOT BE RESPONSIBLE FOR ANY CONSEQUENTIAL LOSS OR DAMAGE HOWEVER IT IS CAUSED.

The guarantee for the stainless steel vessel is for twenty five years if the original unit is returned to us **AND PROVIDED THAT:**

(i) It has been installed as per the Design, Installation & Servicing Instructions, relevant standards, regulations and codes of practice.

(ii) It has not been modified, other than by Gledhill.

(iii) It has not been subjected to wrong or improper use or left uncared for.

(iv) It has only been used for the storage of potable water.

(v) It has not been subjected to frost damage.

(vi) The benchmark log book is completed after each annual service.

(vii) The unit has been serviced annually.

It should be noted that the guarantee does not cover:

- the effects of scale build up

- any labour charges associated with replacing the unit or parts.

If the stainless steel vessel proves to be defective either in materials or workmanship we reserve the right to either repair or supply replacements or the closest possible substitute in the case of any obsolete product and will collect and deliver to any address in England, Scotland and Wales (excluding all islands):

(i) free of charge during the first year after delivery by us.

(ii) thereafter at a charge of one twenty fifth of the then current list price during the second year after delivery by us and increasing by a further one twenty fifth on the second and subsequent anniversary of delivery by us.

ACTION IN THE EVENT OF FAILURE

If the stainless steel cylinder develops a leak we will ask for a deposit against the supply of a new one. This will be refunded if the failure is within the terms of the warranty when it has been examined by us.

(e) Solar Panels and ancillary equipment

Gledhill provides a five year warranty for defects in the collectors (except broken glass and collector accessories eg metal edgings). If the collector demonstrably fails to meet one of the requirements of the standard DIN 4757 part 3 we will replace it free of charge based on the date of invoice. We can not be responsible for damage caused by mechanical stress and/or changes caused by weather related influences. The warranty excludes minor surface damage that does not affect performance or malfunction due to improper assembly or installation.

Please note:

- Installation must have been carried out by a licensed specialized company (heating contractor or plumber) following the version of installation instructions in force.

- Gledhill or its representative was given the opportunity to check complaints on site immediately after any defect occurred.

- Confirmation exists that the system was commissioned properly and that the system was checked and maintenance was performed annually by a specialised company licensed for this purpose.

(f) Components of our products other than Storage Vessels and Integral Pipework.

We will either extend to the purchaser the same terms of warranty as we are given by the manufacturer of the component or if the manufacturer does not give any warranty, replace free of charge any component which becomes defective within two years after the date of the delivery by us and is returned to us at the purchaser's expense but we shall not meet the cost of removal or shipping or return of the component or any other cost charges or damages incurred by the purchaser.

If the appliance manufactured by Gledhill incorporates a factory fitted scale inhibitor then during the period

of three years from the date of delivery Gledhill will replace, free of charge, any plate heat exchanger fitted in the appliance as original equipment in which scale formation occurs that materially reduces the effectiveness of the plate heat exchanger. This guarantee does not extend to any other component installed within the Gledhill appliance or elsewhere in the Purchasers domestic water system.

9.4.

9.4.1. In respect of goods supplied by us and in respect of any installation work carried out by or on our behalf, our entire liability and the purchaser's sole remedies (subject to the Guarantees) shall be as follows:-

- (a) We accept liability for death or personal injury to the extent that it results from our negligence or that of our employees
- (b) Subject to the other provisions of this clause 9 we accept liability for direct physical damage to tangible property to the extent that such damage is caused by our negligence or that of our employees, agents or subcontractors.
- (c) Our total liability to the purchaser over and above any liability to replace under the Guarantees (whether in contract or in tort including negligence) in respect of any one cause of loss or damage claimed to result from any breach of our obligations hereunder, shall be limited to actual money damages which shall not exceed £20,000 provided that such monetary limit shall not apply to any liability on the part of ourselves referred to in paragraph (a) above
- (d) Except as provided in paragraph (a) above but otherwise notwithstanding any provision herein contained in no event shall we be liable for the following loss or damage howsoever caused and even if foreseeable by us or in our contemplation:-
 - (i) economic loss which shall include loss of profits, business revenue, goodwill or anticipated savings
 - (ii) damages in respect of special indirect or consequential loss or damage (other than death, personal injury and damage to tangible property)
 - (iii) any claim made against the purchaser by any other party (save as expressly provided in paragraph (b) above)
- (e) Except in respect of our liability referred to in paragraph (a) above no claim may be made or action brought (whether in contract or in tort including negligence) by the purchaser in respect of any goods supplied by us more than one year after the date of the invoice for the relevant goods.
- (f) Without prejudice to any other term we shall not be liable for any water damage caused directly or indirectly as a result of any leak or other defect in the goods. We cannot control the conditions of use of the goods or the time or manner or location in which they will be installed and the purchaser agrees to be fully responsible for testing and checking all works which include the goods at all relevant times (up to, including and after commissioning) and for taking all necessary steps to identify any leaks and prevent any damage being caused thereby.
- (g) Nothing in these Conditions shall confer on the purchaser any rights or remedies to which the purchaser would not otherwise be legally entitled

10. LOSS OR INJURY

Notwithstanding any other provision contained herein the purchaser's hereby agree to fully indemnify us against any damages losses costs claims or expenses incurred by us in respect of any claim brought against us by any third party for:-

- (a) any loss injury or damage wholly or partly caused by any goods supplied by us or their use.
- (b) any loss injury or damage wholly or partly caused by the defective installation or substandard workmanship or materials used in the installation of any goods supplied by us.
- (c) any loss injury or damage in any way connected with the performance of this contract.
- (d) any loss resulting from any failure by the purchaser to comply with its obligations under these terms as to install and/or check works correctly.

PROVIDED that this paragraph will not require the purchaser to indemnify us against any liability for our own acts of negligence or those of our employees agents or sub-contractors

FURTHER in the case of goods supplied by us which are re-sold and installed by a third party by the purchaser it will be the sole responsibility of the purchaser to test the goods immediately after their installation to ensure that inter alia they are correctly installed and in proper working order free from leaks and are not likely to cause any loss injury or damage to any person or property.

11. VARIATION OF WARRANTY AND EXCLUSION

Should our warranty and exclusion be unacceptable we are prepared to negotiate for variation in their terms but only on the basis of an increase in the price to allow for any additional liability or risk which may result from the variation.

Purchasers are advised to insure against any risk or liability which they may incur and which is not covered by our warranty.

12. RISK AND RETENTION OF TITLE

- (a) goods supplied by us shall be at the Purchaser's risk immediately upon delivery to the Purchaser or into custody on the Purchaser's behalf or to the Purchaser's Order. The Purchaser shall effect adequate insurance of the goods against all risks to the full invoice value of the goods, such insurance to be effective from the time of delivery until property in the goods shall pass to the Purchaser as hereinafter provided.
- (b) property in the goods supplied hereunder will pass to the Purchaser when full payment has been made by the Purchaser to us for :-
 - (i) the goods of the subject of this contract.
 - (ii) all other goods the subject to of any other contract between the Purchaser and us which, at the time of payment of the full price of the goods sold under this contract, have been delivered to the Purchaser but not paid for in full.
- (c) until property in the goods supplied hereunder passes to the Purchaser in accordance with paragraph (2) above.
 - (i) the Purchaser shall hold the goods in a fiduciary capacity for us and shall store the same separately from any other goods in the Purchaser's possession and in a manner which enables them to be identified as our goods.
 - (ii) the Purchaser shall immediately return the goods to us should our authorised representative so request. All the necessary incidents associated with a fiduciary relationship shall apply.
- (d) the Purchaser's right to possess the goods shall cease forthwith upon the happening of any of the following events, namely :-
 - (i) if the Purchaser fails to make payment in full for the goods within the time stipulated in clause 4 hereof.
 - (ii) if the Purchaser, not being a company, commits any act of bankruptcy, makes a proposal to his or her creditors for a compromise or does anything which would entitle a petition for a Bankruptcy Order to be presented.
 - (iii) if the Purchaser, being a company, does anything or fails to do anything which would entitle an administrator or an administrative receiver or a receiver to take possession of any assets or which would entitle any person to present a petition for winding up or to apply for an administration order.
- (e) the Purchaser hereby grants to us an irrevocable licence to enter at any time any vehicle or premises owned or occupied by the Purchaser or in the possession of the Purchaser for the purposes of repossessing and

recovering any such goods the property in which has remained in us under paragraph (2) above. We shall not be responsible for and the Purchaser will indemnify us against liability in respect of damage caused to any vehicle or premises in such repossession and removal being damaged which it was not reasonably practicable to avoid.

- (f) notwithstanding paragraph (3) hereof and subject to paragraph (7) hereof, the Purchaser shall be permitted to sell the goods to third parties in the normal course of business. In this respect the Purchaser shall act in the capacity of our commission agent and the proceeds of such sale :-
 - (i) shall be held in trust for us in a manner which enables such proceeds to be identified as such, and :
 - (ii) shall not be mixed with other monies nor paid into an overdrawn bank account.We, as principal, shall remunerate the Purchaser as commission agent a commission depending upon the surplus which the Purchaser can obtain over and above the sum, stipulated in this contract of supply which will satisfy us.
- (g) in the event that the Purchaser shall sell any of the goods pursuant to clause (6) hereof, the Purchaser shall forthwith inform us in writing of such sale and of the identity and address of the third party to whom the goods have been sold.
- (h) if, before property in the goods passes to the Purchaser under paragraph (2) above the goods are or become affixed to any land or building owned by the Purchaser it is hereby agreed and declared that such affixation shall not have the effect of passing property in the goods to the Purchaser. Furthermore if, before property in the goods shall pass to the Purchaser under paragraph (2) hereof, the goods are or become affixed to any land or building (whether or not owned by the Purchaser), the Purchaser shall:-
 - (i) ensure that the goods are capable of being removed without material injury to such land or building.
 - (ii) take all necessary steps to prevent title to the goods from passing to the landlord of such land or building.
 - (iii) forthwith inform us in writing of such affixation and of the address of the land or building concerned.The Purchaser warrants to repair and make good any damage caused by the affixation of the goods to or their removal from any land or building and to indemnify us against all loss damage or liability we may incur or sustain as a result of affixation or removal.
 - (i) in the event that, before property in the goods has passed to the Purchaser under paragraph (2) hereof, the goods or any of them are lost, stolen, damaged or destroyed :-
 - (ii) the Purchaser shall forthwith inform us in writing of the fact and circumstances of such loss, theft, damage or destruction.
 - (iii) the Purchaser shall assign to us the benefit of any insurance claim in respect of the goods so lost, stolen, damaged or destroyed.

13. NON-PAYMENT

If the Purchaser shall fail to make full payment for the goods supplied hereunder within the time stipulated in clause 4 hereof or be in default of payment for any other reason then, without prejudice to any of our other rights hereunder, we shall be entitled to stop all deliveries of goods and materials to the Purchaser, including deliveries or further deliveries of goods under this contract. In addition we shall be entitled to terminate all outstanding orders.

14. VALUE ADDED TAX

All prices quoted are exclusive of Value Added Tax which will be charged at the rate ruling at the date of despatch of invoice.

15. TRADE SALES ONLY

We are only prepared to deal with those who are not consumers within the terms of the Unfair Contract Terms Act 1977, the Sale of Goods Act 1979 and the Supply of Goods and Services Act 1982. Accordingly any person who purchases from us shall be deemed to have represented that he is not a consumer by so purchasing.

16. JURISDICTION

The agreement is subject to English law for products delivered in England and Scottish law for products delivered in Scotland and any dispute hereunder shall be settled in accordance therewith dependent upon the location.

